



ISO-PSC Polygon Modular Grooving System



- ISO PSC 40 / 50 base holder
- Modular system with compact, stable design
- Cassettes for soft and hard grooving (GND / TGA / CGA)
- Repeatability of interface $\pm 2 \mu\text{m}$
- Internal coolant supply directly to the cutting edge

ISO-PSC Polygon Modular GND Grooving System

General Features

New grades and chipbreakers have been added to the already established GND grooving system with polygon shank and a flexible and economical cassette system for inserts. An array of chipbreakers improves the efficiency in chip control in various applications such as grooving, turning, profiling and cut-off.

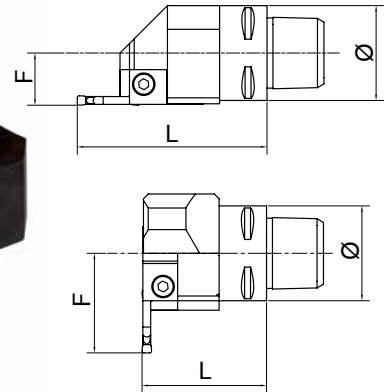

Advantages

- GND inserts for soft grooving from 2,0 - 6,0 mm width
- Expanded grade selection with 9 different chipbreakers for a wide application range
- Provides excellent chip control
- Achieves stable long tool life

Holder

Cat. No. R / L	R	L	Ø (mm)	F (mm)	L (mm)	Cap Screw	Tightening Torque (N·m)	Spanner
PSC40GM00□	●	●	40	22	80	BFTX0619N	7,5 Nm	LT25
PSC50GM00□	●	●	50	27				
PSC40GM90□	●	●	40	42	52,5			
PSC50GM90□	●	●	50	47	55,0			



Cassette

Cat. No. R / L	R	L	Grooving Width w (mm)	Grooving Depth (mm)	Inserts	Cap Screw	Tightening Torque (N·m)	Spanner
GNDCM□212	●	●	2	12	GCM □20□□-□□	BX0512	5,0 Nm	LH040
GNDCM□312	●	●	3		GCM □30□□-□□			
GNDCM□418	●	●	4	18	GCM □40□□-□□		6,0 Nm	
GNDCM□518	●	●	5		GCM □50□□-□□			
GNDCM□618	●	●	6		GCM □60□□-□□			

Grade Selection

	P Steel	M Stainless Steel	K Cast Iron	S Exotic Alloy	N Non Ferrous Metals
1st Recommendation	AC530U AC1030U* PVD	AC530U AC1030U* PVD	AC425K CVD	AC520U PVD	H10 Uncoated Carbide
2nd Recommendation	Insufficient wear resistance ↑ Importance of surface finish ↑ Chipping countermeasures ↓	Insufficient wear resistance ↑ Chipping countermeasures ↓	Chipping countermeasures ↑ Insufficient wear resistance ↓	Chipping countermeasures ↑ Insufficient wear resistance ↓	
	AC520U PVD	AC520U PVD	AC520U PVD	AC520U PVD	
	Insufficient wear resistance ↑ Chipping countermeasures ↓	Insufficient wear resistance ↑ Chipping countermeasures ↓	Chipping countermeasures ↑ Insufficient wear resistance ↓	Chipping countermeasures ↑ Insufficient wear resistance ↓	
	AC830P CVD	AC830P CVD	AC530U AC1030U* PVD	AC530U AC1030U* PVD	
	T2500A Uncoated Cermet				

- Euro stock
- Japan stock

* Will replace grade AC530U

ISO-PSC Polygon Modular GND Grooving System

Inserts

Application	Shape	Type	Cross section of cutting edge	Cat. No.	Coated Carbide				Cermet	Carbide	Dimensions (mm)							
					AC830P	AC425K	AC520U	AC530U	T2500A	H10	w		r _E	ℓ	s			
											Cutting Width	Tolerance						
Grooving / Turning		MG General Purpose		GCM N3004 MG	●	●		●				3,0	±0,03	0,4	21,1	3,8		
				N4008 MG	●	●	○	●				4,0	±0,03	0,8	26,4	4,0		
				N5008 MG	●	●	○	●					5,0	±0,03	0,8	26,4	4,1	
				N6008 MG	●	●	○	●					6,0	±0,03	0,8	26,4	4,5	
		ML Low Feed		GCM N2002 ML			○	●					2,0	±0,03	0,2	21,1	3,6	
				N3002 ML	●	●		●	○				3,0	±0,03	0,2	21,1	3,8	
				N4004 ML	●	●		●		○				4,0	±0,03	0,4	26,4	4,0
				N5004 ML	●	●	○	●						5,0	±0,03	0,4	26,4	4,1
				N6004 ML	●	●	○	●						6,0	±0,03	0,4	26,4	4,5
Copying / Cut-Off		GG General Purpose		GCM N2002 GG	●			●				2,0	±0,03	0,2	21,1	3,6		
				N3002 GG	●		○	●					3,0	±0,03	0,2	21,1	3,8	
				N4002 GG	●			●					4,0	±0,03	0,2	26,4	4,0	
				N5002 GG	●		○	●						5,0	±0,03	0,2	26,4	4,1
				N6002 GG	●		○	●						6,0	±0,03	0,2	26,4	4,5
		GL Low Feed		GCM N3004 GL	●			●					3,0	±0,03	0,4	21,1	3,8	
				N4004 GL	●			●					4,0	±0,03	0,4	26,4	4,0	
				N5004 GL	●		○	●						5,0	±0,03	0,4	26,4	4,1
				N6004 GL	●		○	●						6,0	±0,03	0,4	26,4	4,5
		GF Low Cutting Force		N2002 GF			○	●	○				2,0	±0,03	0,2	21,1	3,6	
				N3002 GF	●			●	○				3,0	±0,03	0,2	21,1	3,8	
				N4002 GF	●			●	●	○				4,0	±0,03	0,2	26,4	4,0
				N5002 GF	●			●	●					5,0	±0,03	0,2	26,4	4,1
				N6002 GF	●			●	●					6,0	±0,03	0,2	26,4	4,5
Copying		RG General Purpose		GCM N3015 RG	●	●	○	●	○			3,0	±0,03	1,5	21,1	3,8		
				N4020 RG	●	●		●	○				4,0	±0,03	2,0	26,4	4,0	
				N5025 RG	●	●		●						5,0	±0,03	2,5	27,2	4,1
				N6030 RG	●	●	○	●						6,0	±0,03	3,0	27,5	4,5
Face / Necking		RN General Purpose		GCM N2010 RN			○	○				2,0	±0,03	1,0	21,7	3,6		
				N3015 RN	○	○	○	○					3,0	±0,03	1,5	22,4	3,8	
				N4020 RN	○	○	○	○						4,0	±0,03	2,0	28,0	4,0
				N5025 RN	○	○	○	○						5,0	±0,03	2,5	28,1	4,1
				N6030 RN	○	○	○	○						6,0	±0,03	3,0	28,1	4,5
Non Ferrous Metals		GA General Purpose		GCG N2002 GA						○		2,0	±0,025	0,2	21,1	3,6		
				N3002 GA						○			3,0	±0,025	0,2	21,1	3,8	
				N4004 GA						○			4,0	±0,025	0,4	26,4	4,0	
				N5004 GA						○			5,0	±0,025	0,4	26,4	4,1	
				N6004 GA						○			6,0	±0,025	0,4	26,4	4,5	

Application	Shape	Type	Cross section of cutting edge	Cat. No. R / L	Coated Carbide				Cermet	Carbide	Dimensions (mm)									
					AC830P	AC425K	AC520U	AC530U	T2500A	H10	w		r _E	ℓ	s					
					R	L	R	L	R	L	R	L				R	L	Cutting Width	Tolerance	
Cut-Off		CG General Purpose		GCM □2002 CG 05	●	●		○	○	●	●				2,0	±0,03	0,2	21,1	3,6	
				□3002 CG 05	●	●		○	○	●	●					3,0	±0,03	0,2	21,3	3,8
				□4002 CG 05	●	●		○	○	●	●					4,0	±0,03	0,2	26,7	4,0

- Euro stock
- Japan stock

Additional cutting widths from 1,25 - 8,0 mm are available for our GND square holder. ⇨ Please see catalogue chapter F

ISO-PSC Polygon Modular TGA Grooving System

General Features

Thanks to our new modular grooving system, cassettes for TGA inserts have been added to the modular system for soft grooving. Triangular TGA inserts with integral chipbreakers achieve outstanding chip control. Combined with AC530U grade TGA inserts cover a wide application range for machining of steel, stainless steel and cast iron.



P M K N S H

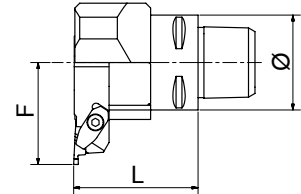
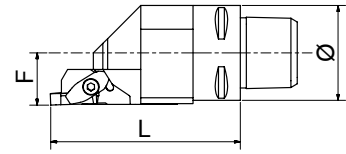

Advantages

- TGA inserts for soft grooving from 1,5 - 4,5 mm width
- AC530U grade with Super ZX ultra hard coating
- Increased productivity thanks to extended tool life

Holder

Cat. No. R / L	R	L	Ø (mm)	F (mm)	L (mm)	Cap Screw	Tightening Torque (N·m)	Spanner
PSC40GM00□	●	●	40	22	80	BFTX0619N	7,5 N·m	LT25
PSC50GM00□	●	●	50	27				
PSC40GM90□	●	●	40	42	52,5			
PSC50GM90□	●	●	50	47	55,0			



Cassette

Cat. No. R / L	R	L	Grooving Width w (mm)	Grooving Depth ℓ (mm)	Insert	Insert Screw	Tightening Torque (N·m)	Spanner	Clamp Finger	Cap Screw	Tightening Torque (N·m)	Spanner
GWCCM□25	●	●	1,5 - 2,3	3,9	TGA □4□□□BF	BFTX0511N	5,0 N·m	TRX20	CLWN01	BX0414	3,0 N·m	LH030
GWCCM□35	●	●	2,5 - 4,5	5,4	TGA □4□□□BF							

Inserts

Cat. No. R / L	Coated		Dimensions (mm)			
	AC530U		() in ℓ presents max. depth			
	R	L	w	ℓ	r	e
TGA□4150BF	●	●	1,50	3,9	0,2	0,250
TGA□4165BF	○	○	1,65			0,175
TGA□4175BF	○	○	1,75			0,125
TGA□4185BF	○	○	1,85	External (3,5) Internal (2,5)	0,2	0,075
TGA□4200BF	●	●	2,00			
TGA□4220BF	○	○	2,20	5,4	0,3	0
TGA□4230BF	○	○	2,30			
TGA□4250BF	●	●	2,50			
TGA□4265BF	○	○	2,65			
TGA□4270BF	○	○	2,70			
TGA□4280BF	○	○	2,80			
TGA□4300BF	●	●	3,00			
TGA□4320BF	○	○	3,20			
TGA□4330BF	○	○	3,30			
TGA□4350BF	●	●	3,50			
TGA□4370BF	○	○	3,70			
TGA□4390BF	○	○	3,90			
TGA□4400BF	●	●	4,00	5,4	0,4	0
TGA□4410BF	○	○	4,10			
TGA□4420BF	○	○	4,20			
TGA□4430BF	○	○	4,30			
TGA□4440BF	○	○	4,40			
TGA□4450BF	●	●	4,50			

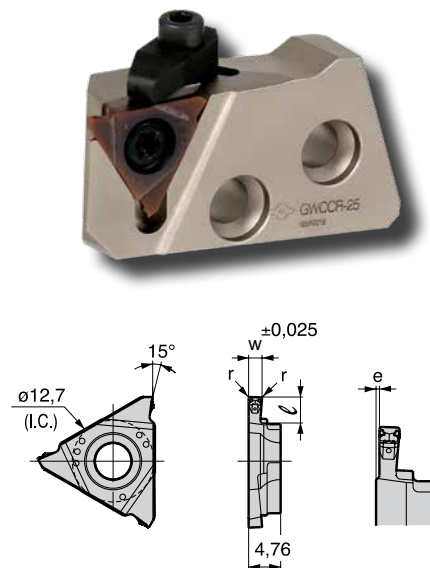

- Euro stock
- Japan stock

ISO-PSC Polygon Modular CGA Grooving System

General Features

In addition to GND and TGA inserts for soft grooving, tangential CGA inserts enable hard grooving with SUMIBORON grades. Uncoated CBN grade BN250 developed for continuous grooving and coated CBN grade BNC30G for interrupted grooving applications.



P M K N S H

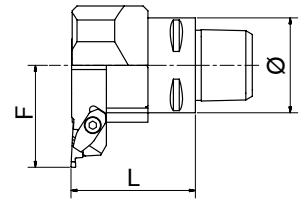
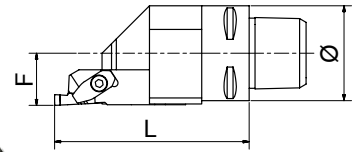

Advantages

- CGA inserts for hard grooving from 1,5 - 6,0 mm width
- Uncoated CBN grade BN250 for continuous grooving
- Coated CBN grade BNC30G for interrupted grooving
- Both grades achieve excellent wear and fracture resistance in their area

Holder

Cat. No. R / L	R	L	Ø (mm)	F (mm)	L (mm)	Cap Screw	Tightening Torque (N·m)	Spanner
PSC40GM00□	●	●	40	22	82,0	BFTX0619N	7,5 Nm	LT25
PSC50GM00□	●	●	50	27				
PSC40GM90□	●	●	40	43	52,5			
PSC50GM90□	●	●	50	48	55,0			



Cassette

Cat. No. R / L	R	L	Grooving Width w (mm)	Grooving Depth ℓ (mm)	Inserts	Insert Screw	Tightening Torque (N·m)	Spanner	Clamp Finger	Cap Screw	Tightening Torque (N·m)	Spanner
GWBCM□45	●	●	1,5 - 2,0	3,5	CGA1504□□0	BFTX0511N	5,0 Nm	TRX20	CLWN01	BX0414	3,0 Nm	LH030
			2,5 - 3,0	4,0								
GWBCM□60	●	●	3,5 - 6,0	5,0	CGA1506□□0							

Inserts

Cat. No. R / L	Stock				Dimensions (mm)					Applicable Holder
	BN250		BNC30G		w (*)	ℓ	r	I.C.	T	
	R	L	R	L						
CGA□1504 150	●	●	●	●	1,5	3,5	0,2	15,875	4,76	GWBCMR45 GWBCML45
CGA□1504 200	●	●	●	●	2,0					
CGA□1504 250	●	●	●	●	2,5					
CGA□1504 300	●	●	●	●	3,0					
CGA□1504 350	●	●	●	●	3,5					
CGA□1504 400	●	●	●	●	4,0					
CGA□1504 450	●	●	●	●	4,5					
CGA□1506 500	●	●	●	●	5,0	5,0				
CGA□1506 550	●	●	●	●	5,5					
CGA□1506 600	●	●	●	●	6,0					

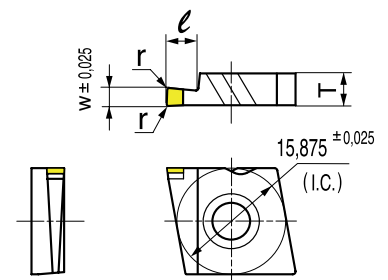

- Euro stock
- Japan stock

* Additional cutting widths on request

ISO-PSC Polygon Modular Grooving System

■ Recommended Cutting Conditions

Please refer to the detail information in our catalogue to select the best choice of breaker, grade and condition. Please see related chapters as shown below:

■ GND ⇒ Please see chapter F

Work Material	P Carbon Steel / Alloy Steel				M Stainless Steel			K Cast Iron				S Exotic Alloy			N
Grade	AC830P	AC520U	AC530U	T2500A	AC830P	AC520U	AC530U	AC425K	AC520U	AC530U	AC1030U	AC520U	AC530U	AC1030U	H10
Cutting Speed (m/min)	80~200	80~200	50~200	50~200	70~150	70~150	50~150	80~200	60~200	50~200	50~200	20~80	20~60	20~60	150~300

■ TGA ⇒ Please see chapter F

Work Material	P Carbon Steel / Alloy Steel	M Stainless Steel
Grade	AC530U	AC530U
Cutting Speed (m/min)	50~180	50~160

■ CGA ⇒ Please see chapter M

Work Material	H Hardened Steel	
Grade	BN250	BNC30G
Cutting Speed (m/min)	80~120	



(Germany)
SUMITOMO ELECTRIC Hartmetall GmbH
Konrad-Zuse-Straße 9, 47877 Willich

Tel. +49(0)2154 4992-0, Fax +49(0)2154 4992-161
Info@SumitomoTool.com
www.SumitomoTool.com



(UK and Ireland)
SUMITOMO ELECTRIC Hardmetal Ltd.
Summerleys Road, Princes Risborough
Buckinghamshire HP27 9PW, UK

Tel. +44(0)1844 342081, Fax: +44(0)1844 342415
enquiries@sumitomo-hardmetal.co.uk
www.SumitomoTool.com



Distributed by: