



WERKZEUGTECHNIK

TOOLING TECHNOLOGY

HAIMER MILL Power Series

HAIMER MILL Power Series VHM Schafffräser – Einzigartige Vorteile/ HAIMER MILL Power Series Solid Carbide End Mills – Unique Advantages	24
Formeln – Grundlagen Fräsen/Formulas – Milling Basics	27

HAIMER Safe-Lock

Safe-Lock Werkzeugauszugsicherung/Safe-Lock Pull Out Protection	28
---	----

HAIMER VHM Schafffräser / Solid Carbide End Mills

Übersicht VHM Schafffräser/Overview Solid Carbide End Mills	32
Erklärung Icons, Artikel Code, Materialliste/Explanation of Icons, Article Code, Material List	38
VHM Schafffräser/Solid Carbide End Mills	41

HAIMER Duo-Lock Fräsköpfe / Duo-Lock Milling Heads

Eigenschaften und Vorteile/Characteristics and Advantages	90
Übersicht Duo-Lock/Overview Duo-Lock	92
Erklärung Icons, Artikel Code, Materialliste/Explanation of Icons, Article Code, Material List	100
Duo-Lock Fräsköpfe/Duo-Lock Milling Heads	103

Duo-Lock Zubehör / Duo-Lock Accessories

Duo-Lock Rohlinge/Duo-Lock Blanks	178
Duo-Lock Verlängerungen/Duo-Lock Extensions	190
Duo-Lock Reduzierungen/ Duo-Lock Reductions	199
Duo-Lock Spannzangen/Duo-Lock Collets	200
Duo-Lock Monoblockaufnahmen/Duo-Lock Monoblock Holders	201
Duo-Lock Die and Mold Aufnahmen/ Duo-Lock Die and Mold Chucks	206
Duo-Lock Längenvoreinstell-Werkzeug/Duo-Lock Length Presetting Tool	208
Duo-Lock Torque Master/Duo-Lock Torque Master	209
Duo-Lock Gabelstücke für Torque Master/Duo-Lock Inserts for Torque Master	210
Duo-Lock Rollenspannschlüssel/Duo-Lock Roller Bearing Wrench	211
Duo-Lock Handschlüssel/Duo-Lock Hand Wrench	212
Duo-Lock Spannzangen Spannvorrichtung/Duo-Lock Collet Clamping Device	212
Drehmomentschlüssel/Torque Wrench	213

Sonderanfragen / Special Requests

Formulare Sonderanfrage/Form Special Requests	216
---	-----

HAIMER MILL Power Series

VHM Schafffräser – Einzigartige Vorteile Solid Carbide End Mills – Unique Advantages

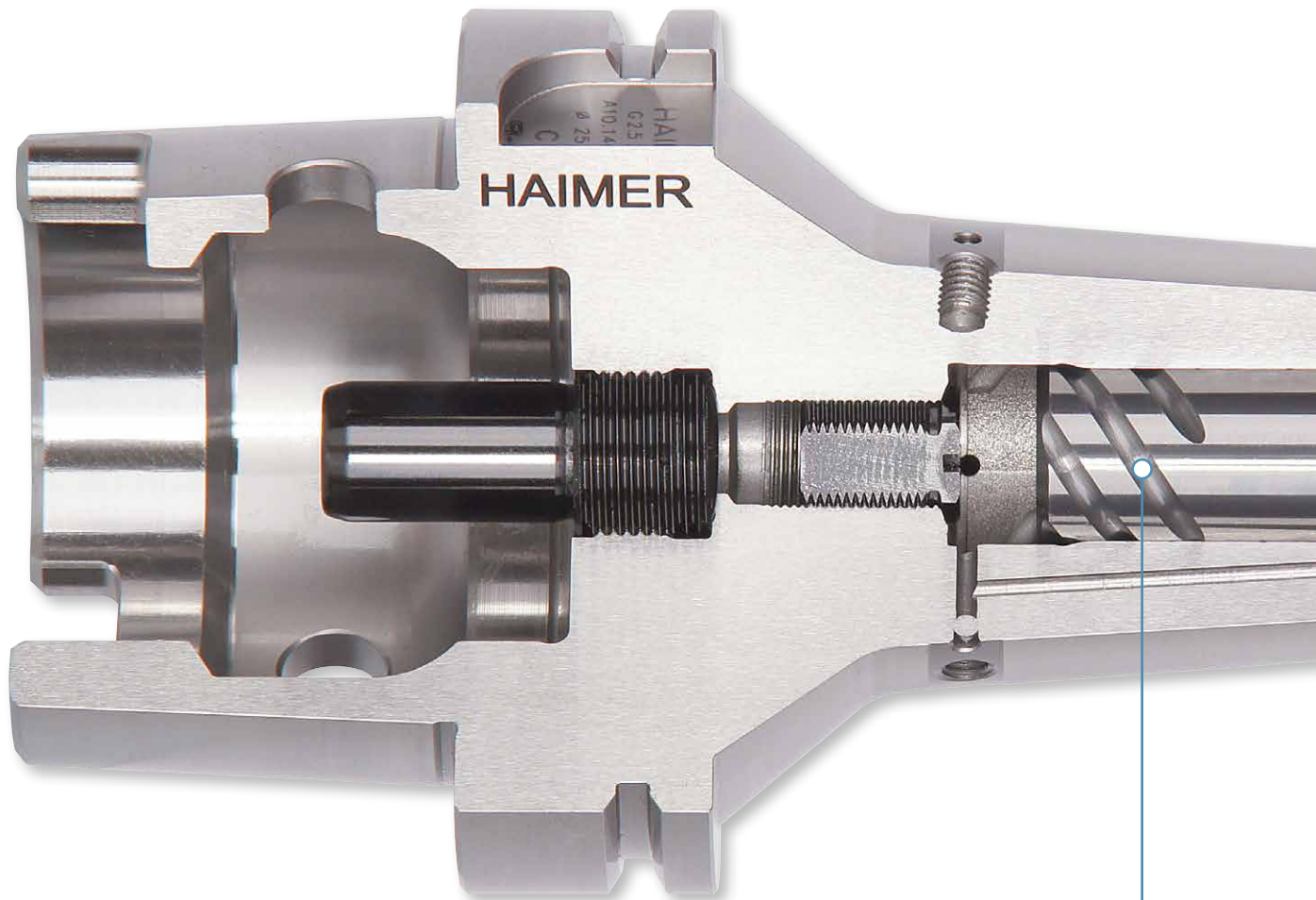

HAIMER Qualität – 100% garantiert:

- Konstante Leistungsfähigkeit der Werkzeuge
- Maximale Prozesssicherheit

HAIMER Quality – 100% guarantee:

- Consistent cutting tool performance
- Maximized process reliability

Safe-Lock Schaft

- Maximale Auszugsicherheit
- Beste Rundlaufgenauigkeit
- Maximales Zerspanvolumen
- Auch bei Werkzeugaufnahmen ohne Safe-Lock gleichbleibende Haltekräfte und Drehmomente

Safe-Lock shank

- Maximum pull-out protection
- Best run-out accuracy
- Maximum cutting volume
- Even at tool holders without Safe-Lock consistent clamping forces and torques

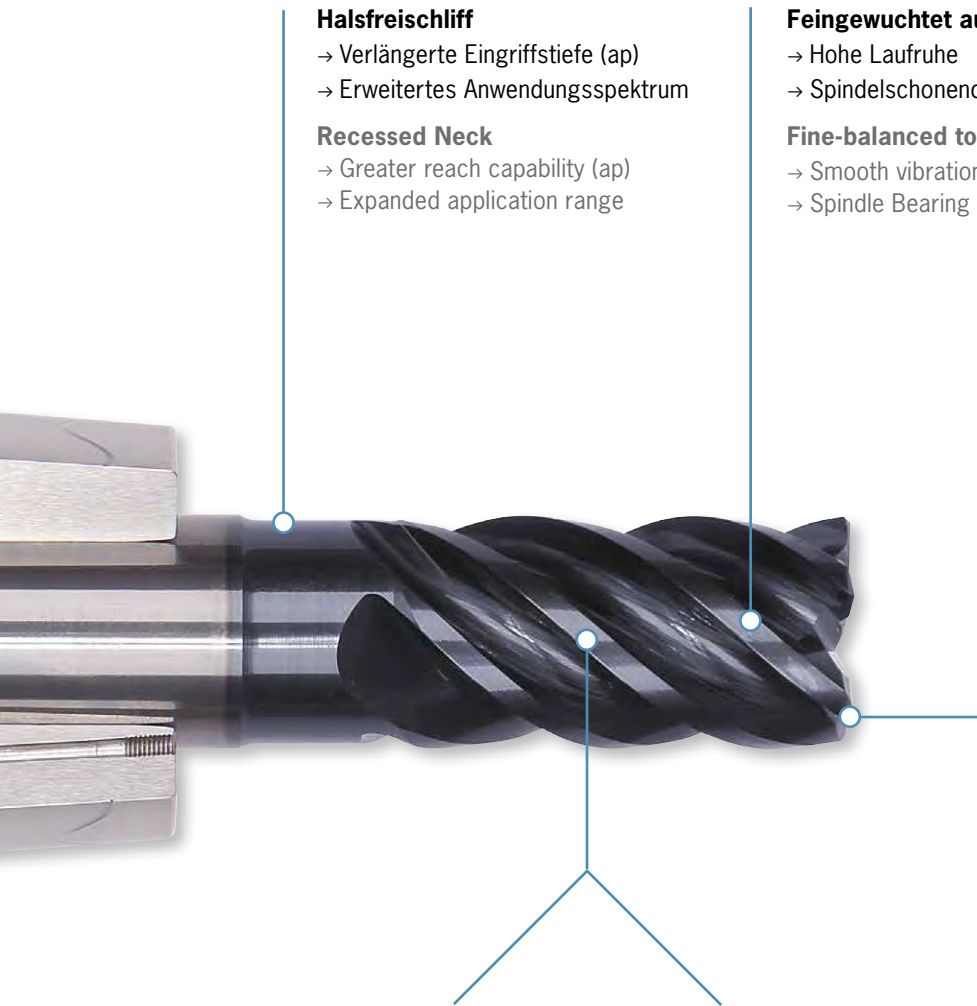

Halsfreischliff

- Verlängerte Eingriffstiefe (ap)
- Erweitertes Anwendungsspektrum

Recessed Neck

- Greater reach capability (ap)
- Expanded application range

Feingewuchtet auf < 1gmm

- Hohe Laufruhe
- Spindelschonend

Fine-balanced to < 1gmm

- Smooth vibration-free rotation
- Spindle Bearing Protection

Max. 5 µm Rundlaufgenauigkeit

- Optimale Wiederholgenauigkeit
- Höhere Bearbeitungsqualität
- Hohe Laufruhe
- Erhöhte Werkzeugstandzeit durch gleichmäßigen Verschleiß

Max. 5 µm run-out accuracy

- Optimized repeatability
- Better machining quality
- Reduced chatter
- Increased tool life thanks to equal tool wear

Hochpräzise Schneidkantenverrundung

- Hohe Laufruhe
- Maximale Einsatzparameter

High precision rounding of cutting edges

- Less prone to chipping
- Wide application range

Polierte Oberflächen

- Optimierte Spanabfuhr
- Verlängerte Werkzeugstandzeit

Polished Surfaces

- Optimized chip removal
- Increased tool life



Stoßgeschützte Verpackung

- Top-Qualität mit jeder Lieferung

Shock-resistant packaging

- Top quality at each delivery



HAIMER MILL Power Series

**Für maximale Zerspanleistung und beste
Standzeiten**

For maximum cutting performance and tool life

FORMELN – GRUNDLAGEN FRÄSEN

FORMULAS – MILLING BASICS

Geschwindigkeit, Vorschub und Fräsen

Cutting speed, Feed and Milling

Beschreibung Description	Formel Formula	Legende Legend
Drehzahl RPM	$n = \frac{v_c \cdot 1000}{D \cdot \pi}$	a_e = Radiale Schnittbreite [mm] / Radial cutting width [mm] a_p = Axiale Schnitttiefe [mm] / Axial cutting depth [mm] D = Durchmesser [mm] / Diameter [mm]
Schnittgeschwindigkeit Cutting speed	$v_c = \frac{D \cdot \pi \cdot n}{1000}$	f_n = Vorschub pro Umdrehung [mm/U] / Feed per rotation [mm/r] f_z = Zahnvorschub [mm/Z] / Feed per tooth [mm/Z]
Vorschub pro Zahn Feed per tooth	$f_z = \frac{f_n}{z}$ $f_z = \frac{v_f}{z \cdot n}$	h_m = Mittlere Spandicke [mm] / Average chip thickness [mm] k_c = Spezifische Schnittkraft [N/mm ²] / Specific cutting force [N/mm ²] l = Arbeitslänge [mm] / Length of cut [mm]
Vorschub pro Umdrehung Feed per rotation	$f_n = f_z \cdot z$ $f_n = \frac{v_f}{n}$	n = Drehzahl [U/min] / Rounds per minute [rpm] P_a = Antriebsleistung [kW] / Drive power [kW]
Vorschubgeschwindigkeit Feed rate	$v_f = f_z \cdot z \cdot n$	Q = Zerspanvolumen [cm ³ /min] / Material removal rate [cm ³ /min] T_c = Bearbeitungszeit [min] / Cutting time [min] v_c = Schnittgeschwindigkeit [m/min] / Cutting speed [m/min]
Zerspanvolumen Material removal rate	$Q = \frac{a_p \cdot a_e \cdot v_f}{1000}$	v_f = Vorschubgeschwindigkeit [mm/min] / Feed rate [mm/min] z = Anzahl der Zähne / Number of teeth
Antriebsleistung Drive power	$P_a = \frac{a_p \cdot a_e \cdot v_f \cdot k_c}{60 \cdot 10^6 \cdot \eta_{mt}}$	$\pi = 3,14\dots$ η_{mt} = Wirkungsgrad / Efficiency rate
Bearbeitungszeit Cutting time	$T_c = \frac{l}{v_f} = \text{min}$	
Mittlere Spandicke Average chip thickness	$h_m = f_z \cdot \sqrt{\frac{a_e}{D}}$	

SAFE-LOCK® AUSZUGSICHERUNG – DAS SYSTEM

SAFE-LOCK® PULL OUT PROTECTION – THE SYSTEM



Mit Safe-Lock kein Werkzeugauszug
No pull out of the tool with Safe-Lock

SAFE-LOCK® – der Sicherheitsgurt für Ihre Werkzeuge

In der Hochleistungszerspanung kann es vermehrt zu Werkzeugauszügen kommen. Ursache dafür können Mikrobewegungen sein. Diese entstehen bei hohen Drehzahlen und axialen Zugkräften. Selbst Werkzeugaufnahmen mit hohen Haltekräften können dies nicht verhindern. **Abhilfe bietet Safe-lock®**

Das revolutionäre System wird zusätzlich zum Kraftschluss mit einem Formschluss verbunden.

Dies geschieht über die eingeschliffenen Nuten im Spannschaft des Werkzeugs und dem eingebrachten Gegenstück im Werkzeughalter. Somit werden sämtliche Bewegungen des Werkzeugs gestoppt.

SAFE-LOCK® – The safety belt for your tools

In high performance cutting (HPC), it is possible for the cutting tool to be pulled out of the chuck. The reason is a slow micro-creeping motion. It happens when cutting at high speeds and with high pull out forces. Even chucks with extremely high clamping force cannot prevent micro-creeping. High-quality work pieces become scrap as a result. **The Safe-lock® system offers a solution.**

The revolutionary system secures the cutting tool via the high accuracy frictional clamping in conjunction with a positive locking form fit connection.

This is accomplished by means of grooves in the cutting tools and the corresponding form fit in the tool holder. Resulting in a connection in which all potential movements of the cutting tool are prevented.

Ihre Vorteile Mit SAFE-LOCK® auf der sicheren Seite:

- Für die Hochleistungszerspanung
- Hochpräzise Spannung durch Schrumpf- und Spannzangentechnik
- Hohe Drehmomentübertragung durch Kraft und Formschluss
- Kein Werkzeugauszug (s. Abb. unten links)
- Keine Verdrehung
- Patent erteilt: Lizenzierung möglich



**Maximales Zerspanvolumen
bei absoluter Prozesssicherheit**

Your advantages On the safe side with SAFE-LOCK® :

- For High Performance Cutting
- Highly accurate clamping due to shrink fit or collet chuck technology
- High torque due to form closed clamping
- No tool pull out (see image on the left)
- No twisting
- Patent granted: licensing possible



**Maximum metal removal rate
with absolute process reliability**

SAFE-LOCK® AUSZUGSICHERUNG – FUNKTIONSWEISE SAFE-LOCK® PULL OUT PROTECTION – FUNCTIONALITY

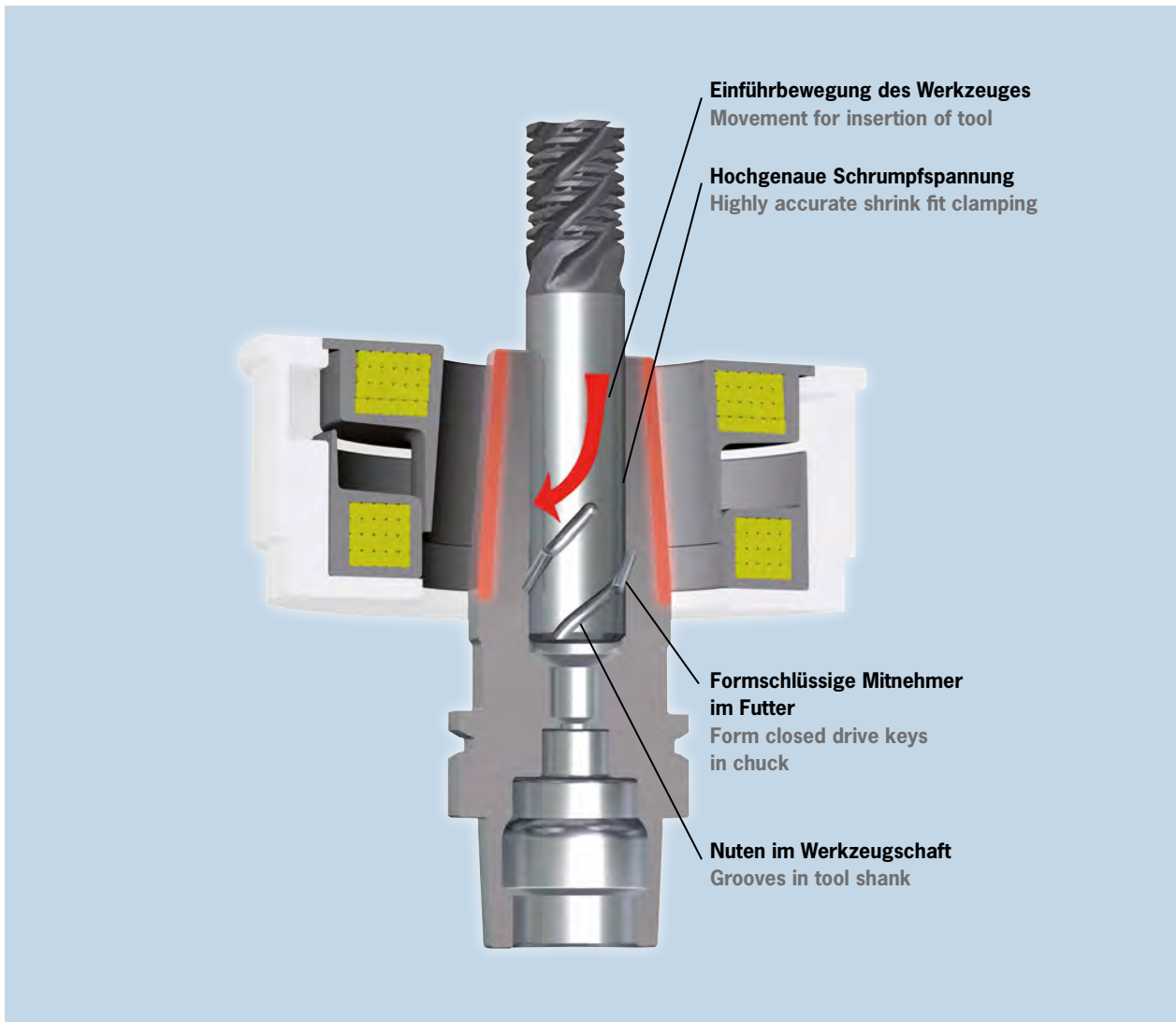

POWER SHRINK CHUCK MIT/WITH SAFE-LOCK



POWER COLLET CHUCK MIT/WITH SAFE-LOCK



SAFE-LOCK® FRAGEN UND ANTWORTEN

SAFE-LOCK® FAQ

FRAGE:

Kann ein Fräser mit Safe-Lock Schaft auch in einer Werkzeugaufnahme ohne Safe-Lock gespannt werden?

ANTWORT:

Werkzeuge mit Safe-Lock Schaft können in jeder Werkzeugaufnahme, die für HA-Schäfte nach DIN 6535 geeignet sind, gespannt werden.

FRAGE:

Sind Werkzeuge mit Safe-Lock Schaft längeneinstellbar?

ANTWORT:

Ja, die Safe-Lock Auszugsicherung erlaubt es, die Werkzeuge problemlos innerhalb der Safe-Lock Nut zu verschieben und somit einfach und schnell auf das gewünschte Z Maß einzustellen.

FRAGE:

Wie schrumpfe ich Werkzeuge mit Safe-Lock Schaft ein?

ANTWORT:

Analog zur Anwendung von Werkzeugen mit HA-Schaft werden Werkzeuge mit Safe-Lock Schaft in die erwärmte Werkzeugaufnahme gesetzt und anschließend mit einer Drehbewegung eingeschrumpft.

FRAGE:

Wie bekomme ich abgebrochene Werkzeuge mit Safe-Lock Schaft aus der Safe-Lock Aufnahme?

ANTWORT:

Mit Hilfe der HAIMER Ausschrumpfvorrichtung (Art.-Nr. 80.126.00) können abgebrochene Werkzeuge trotz der spiralisierten Safe-Lock Nuten problemlos aus der Werkzeugaufnahme entfernt werden.

FRAGE:

Welche Vorteile liefert Safe-Lock im Vergleich zum altbewährten Weldon-Spannsystem?

ANTWORT:

Beim Weldon-System wird das Werkzeug durch die seitliche Spannung aus dem Zentrum gedrückt, was zu verkürzter Werkzeugstandzeit, schlechter Rundlaufgenauigkeit von bis zu 0,05 mm und damit zu ungenügenden Werkstückoberflächen führen kann. Im Vergleich dazu bietet das HAIMER Safe-Lock System neben der Auszugsicherung eine sehr gute Rundlaufgenauigkeit von < 0,003 mm. Nur mit Safe-Lock ist maximales Zerspanvolumen bei absoluter Prozesssicherheit und Präzision möglich!

QUESTION:

Can an end mill with Safe-Lock shank also be clamped into a tool holder without Safe-Lock pins?

ANSWER:

Yes, tools with Safe-Lock shank can be clamped in every frictional tool holder.

QUESTION:

Is the length of tools with Safe-Lock shank adjustable?

ANSWER:

Yes, the pull out protection Safe-Lock allows shifting the tool within the Safe-Lock groove without any problems.

QUESTION:

How can I shrink in tools with Safe-Lock shank?

ANSWER:

Tools with Safe-Lock shank are put in the heated tool holder and are then shrunk in with a twisting movement.

QUESTION:

How can I get out broken tools with Safe-Lock shank from a Safe-Lock tool holder?

ANSWER:

The HAIMER shrink out device (Order No. 80.126.00) helps to get out broken tools despite the spiral-shaped Safe-Lock grooves without any problems.

QUESTION:

What advantages does the Safe-Lock system offer compared to the well-tried Weldon-clamping system?

ANSWER:

Due to the side clamping of the Weldon system, the tool is pushed off center, which causes poor runout accuracy of up to 0,05 mm, and therefore insufficient surface finish and poor tool life. In comparison, HAIMER Safe-Lock provides, in addition to the pull out protection, a very high runout accuracy of < 0,003 mm. Only Safe-Lock allows a maximum metal removal rate combined with absolute process reliability and precision!

SAFE-LOCK® PRAXISBEISPIELE SAFE-LOCK® APPLICATION EXAMPLES

Power Collet Chuck mit Safe-Lock

**Maximales Zerspanvolumen ohne Risiko von
Werkzeugauszug bei bester Oberfläche**

Anwendung:	Nutfräsen
Bauteil:	Titan Block
Material:	Ti6Al4V
Werkzeugaufnahme:	Power Collet Chuck mit Safe-Lock
Maschine:	DMG MORI, DMU 80 P duoBLOCK®
Schnittstelle:	HSK-A 100
Kühlung/Druck:	Emulsion/100 bar
Werkzeug:	Safe-Lock VHM Fräser, Z4, Ø 20 mm
Schnittdaten:	ae: 20 mm ap: 20/32,5/35/37,5 mm fz: 0,07 mm vc: 60 m/min

Power Collet Chuck with Safe-Lock

**Maximum metal removal rate and best surface finish
without risk of pullout**

Application:	Slot milling
Work piece:	Titanium block
Material:	Ti6Al4V
Tool Holder:	Power Collet Chuck with Safe-Lock
Machine:	DMG MORI, DMU 80 P duoBLOCK®
Interface tool:	HSK-A 100
Cooling / pressure:	Emulsion/100 bar
Tool:	Safe-Lock solid carbide end mill, Z4, Ø20mm
Cutting data:	ae: 20 mm ap: 20/32,5/35/37,5 mm fz: 0,07 mm vc: 60 m/min

Power Shrink Chuck mit Safe-Lock

**66 % mehr Standzeit mit Safe-Lock
gegenüber Weldon**

Anwendung:	Taschenfräsen
Bauteil:	Form
Material:	1.2312/40CrMnMoS 8-6, 40 HRC
Werkzeugaufnahme:	Power Shrink Chuck mit Safe-Lock
Maschine:	Mazak FH7800
Schnittstelle:	HSK-A 100
Kühlung:	Luft
Werkzeug:	Safe-Lock VHM Fräser, Z4, Ø 20 mm
Schnittdaten:	ae: 2 mm ap: 35 mm fz: 0,25 mm vc: 180 m/min

Power Shrink Chuck with Safe-Lock

**66 % more tool life with Safe-Lock
compared to Weldon**

Application:	Pocket milling
Work piece:	Mould
Material:	1.2312/40CrMnMoS 8-6, 40 HRC
Tool Holder:	Power Shrink Chuck with Safe-Lock
Machine:	Mazak FH7800
Interface tool:	HSK-A 100
Cooling:	Air
Tool:	Safe-Lock solid carbide end mill, Z4, Ø20mm
Cutting data:	ae: 2 mm ap: 35 mm fz: 0,25 mm vc: 180 m/min

ÜBERSICHT VHM SCHAFTFRÄSER OVERVIEW SOLID CARBIDE END MILLS

Produkte/Products	∅ D1	Seite/Page	Merkmale/Characteristics
E1012NN/E1012NL – HAIMER MILL MULTIFUNKTIONSFÄSER/MULTIFUNCTION END MILL 	∅ 4 – ∅ 10	41	  
E1014UN – HAIMER MILL VIERTELKREISFÄSER/QUADRANT END MILL 	∅ 6 – ∅ 10	43	 
E1014UN/E1016UN – HAIMER MILL ENTGRATFÄSER/CHAMFERING END MILL 	∅ 4 – ∅ 10	45	  
F1003NN – HAIMER MILL Power Series 	∅ 2 – ∅ 20	47	   
F1004NN – HAIMER MILL Power Series 	∅ 2 – ∅ 20	49	   
F1004NN – HAIMER MILL Power Series 	∅ 2 – ∅ 20	51 – 53	   
F1005LL – HAIMER MILL Power Series 	∅ 6 – ∅ 20	55	   
F1005NN – HAIMER MILL Power Series 	∅ 10 – ∅ 32	57	   
F1104NN – HAIMER MILL Power Series SPANBRECHER/CHIP BREAKER 	∅ 6 – ∅ 20	59	   
F1105LL – HAIMER MILL Power Series SPANBRECHER/CHIP BREAKER 	∅ 6 – ∅ 20	61	   







Schaft/Shank	Anwendung/Application	Material/Material
		<p>Haupteinsatz Main Material</p>  <p>auch geeignet für also suitable for</p> 
		<p>Haupteinsatz Main Material</p>  <p>auch geeignet für also suitable for</p> 
		<p>Haupteinsatz Main Material</p>  <p>auch geeignet für also suitable for</p> 
  		<p>Haupteinsatz Main Material</p>  <p>auch geeignet für also suitable for</p> 
  		<p>Haupteinsatz Main Material</p>  <p>auch geeignet für also suitable for</p> 
  		<p>Haupteinsatz Main Material</p>  <p>auch geeignet für also suitable for</p> 
  		<p>Haupteinsatz Main Material</p>  <p>auch geeignet für also suitable for</p> 
  		<p>Haupteinsatz Main Material</p>  <p>auch geeignet für also suitable for</p> 
  		<p>Haupteinsatz Main Material</p>  <p>auch geeignet für also suitable for</p> 
  		<p>Haupteinsatz Main Material</p>  <p>auch geeignet für also suitable for</p> 

















ÜBERSICHT VHM SCHAFTFRÄSER OVERVIEW SOLID CARBIDE END MILLS

Produkte/Products	∅ D1	Seite/Page	Merkmale/Characteristics
F1304NN – HAIMER MILL Power Series SCHRUPPVERZÄHNUNG/ROUGHING 	∅ 6 – ∅ 20	63	   
F2004NN – HAIMER MILL 	∅ 2 – ∅ 20	65	   
F2004NN – HAIMER MILL UNTERMASS/UNDERSIZE 	∅ 5.7 – ∅ 19.5	66	   
F2004NN – HAIMER MILL 	∅ 2 – ∅ 20	67	   
F2004NN – HAIMER MILL 	∅ 2 – ∅ 20	68 – 70	   
F2004LL – HAIMER MILL 	∅ 6 – ∅ 20	71	   
F2014KK – HAIMER MILL 	∅ 2 – ∅ 20	73	   
F4002NN – HAIMER MILL Alu Series 	∅ 2 – ∅ 20	75	   
F4002NN – HAIMER MILL Alu Series 	∅ 2 – ∅ 20	77	   
F4003NN – HAIMER MILL Alu Series 	∅ 2 – ∅ 20	79	   

Schaft/Shank	Anwendung/Application	Material/Material
		<p>Haupteinsatz Main Material</p>  <p>auch geeignet für also suitable for</p> 
		<p>Haupteinsatz Main Material</p>  <p>auch geeignet für also suitable for</p> 
		<p>Haupteinsatz Main Material</p>  <p>auch geeignet für also suitable for</p> 
		<p>Haupteinsatz Main Material</p>  <p>auch geeignet für also suitable for</p> 
		<p>Haupteinsatz Main Material</p>  <p>auch geeignet für also suitable for</p> 
		<p>Haupteinsatz Main Material</p>  <p>auch geeignet für also suitable for</p> 
		<p>Haupteinsatz Main Material</p>  <p>auch geeignet für also suitable for</p> 
		<p>Haupteinsatz Main Material</p>  <p>auch geeignet für also suitable for</p>
		<p>Haupteinsatz Main Material</p>  <p>auch geeignet für also suitable for</p>
		<p>Haupteinsatz Main Material</p>  <p>auch geeignet für also suitable for</p>

ÜBERSICHT VHM SCHAFTFRÄSER OVERVIEW SOLID CARBIDE END MILLS

Produkte/Products	∅ D1	Seite/Page	Merkmale/Characteristics
<p>F4003NN – HAIMER MILL Alu Series</p> 	∅ 2 – ∅ 20	81	   
<p>H2004KN – HAIMER MILL HF SERIES HOCHVORSCHUB KZ/HIGH FEED KZ</p> 	∅ 6 – ∅ 10	83	   
<p>V1002NN – HAIMER MILL Power Series</p> 	∅ 2 – ∅ 20	85	   
<p>V4002NN – HAIMER MILL Alu Series</p> 	∅ 2 – ∅ 20	87	   
<p>V4002NN – HAIMER MILL Alu Series</p> 	∅ 2 – ∅ 20	89	   

Schaft/Shank	Anwendung/Application	Material/Material
		<p>Haupteinsatz Main Material</p> 
		<p>Haupteinsatz Main Material</p>  <p>auch geeignet für also suitable for</p> 
		<p>Haupteinsatz Main Material</p>  <p>auch geeignet für also suitable for</p> 
		<p>Haupteinsatz Main Material</p> 
		<p>Haupteinsatz Main Material</p> 

ERKLÄRUNG ICONS/ARTIKEL CODE/MATERIAL-LISTE EXPLANATION ICONS/ARTICLE CODE/MATERIAL LIST

Erklärung Icons/Explanation Icons

Eigenschaften/Characteristics

Schneidlänge Cutting length	Ähnlich DIN Similar DIN	Drallwinkel Helix angle	Scharfkantig Sharp cutting edge	Eckenfase Corner chamfer	Eckenradius Corner radius	Vollradius Ball Nose	Spitze Spot	Eckradius Edge radius
Zähnezahl 2 Teeth 2	Zähnezahl 3 Teeth 3	Zähnezahl 4 Teeth 4	Zähnezahl 5 Teeth 5	Zähnezahl 6 Teeth 6	Safe-lock® Safe-lock®	Glattschaft Straight shank	Weldon Schaft Weldon shank	Alle drei Schäfte All three shanks

Anwendung/Application

Vorschubrichtung Feed direction	Vorschubrichtung Feed direction	Vorschubrichtung Feed direction	Rampen Ramping	Nutfräsen Slotting	Wälz-/Eckfräsen Side milling	Abrunden Rounding	Fasen Chamfering
Bohren Drilling	Kopieren 3D Milling	V-Nuten V-slotting	Konturfasen Contouring	Fasen Chamfering	Wälzen Side milling		

Kühlung/Coolant

Emulsion Emulsion	Kaltluftdüse Cold air	Trockenbearbeitung Dry machining	Mindermengenschmierung Minimal lubrication	Innenkühlung zentral Central inner cooling

Erklärung Artikel Code/Explanation article code

F	1	0	0	2	M	N	L
Werkzeug-Typ Tool type	Gruppe Group	Ausführung Type	Modifikation Modification	Zähnezahl No. of teeth	Schneidlänge Length of cut	Gesamtlänge Overall length	Schaftausführung Shank type
F- Zylinderfräser Cylindrical end mill	1- Universal 2- Stahl Steel	0- Glatte Schneide Plain cutter	0- Halsfrei- setzung With neck	2- Z2 3- Z3 4- Z4 5- Z5 6- Z6 8- Z8 0- Z10	N- DIN (1.75-2.5xD) L- 2.6-3.5xD	N- DIN6527 L- Lang Long	L- Safe-Lock
E- Entgratfräser Chamfering end mill	< 52HRC 4- Alu 6- Titan/ Inconel	1- Spanbrecher Chip breaker	1- Keine Halsfrei- setzung No Neck		M- 1.5xD K- 1.25xD U- 0.75xD	K- Kurz Short U- Ultrakurz Ultra short	H- Glatt Straight B- Weldon Weldon

Material-Liste/Material list

HAIMER Werkstoff Gruppen HAIMER Material groups		Beispiel Werkstoffe Example material		Werkstoff Information Material information	
		DIN DIN	Werkstoffnr. Material no.	Zugfestigkeit Tensile strength	Inhalt/Härte Content/Hardness
P1	Allg. Bau-, Einsatzstähle General construction steels	S235JR (RST37-2), E295 (St 50-2), C45	1.0038, 1.0050, 1.0503	≤ 800 N/mm ²	bis 25 HRC up to 25 HRC
P2	Werkzeug/Vergütungsstähle Heat treated steels	X38CrMoV5-3, X153CrMoV12, X100CrMoV5, 42CrMo4	1.2367, 1.2379, 1.2363, 1.7225	> 800 N/mm ²	bis 45 HRC up to 45 HRC
M1	Rostfreie Stähle Stainless steels	X8CrNiS18-9, X5CrNi18-10, X46Cr13	1.4305, 1.4301, 1.4034	≤ 650 N/mm ²	
M2	Rostfreie Stähle Stainless steels	X6CrNiMoTi17-12-2, X2CrNiMo17-12-2, X4CrNiMo16-5-1	1.4571, 1.4404, 1.4418	> 650 N/mm ²	
K1	Gusseisen Cast iron	EN-GJL200 (GG20), EN-GJLZ (GG40), EN-GJS-400-15 (GGG40)	0.6020, 0.6040, 0.7040	≤ 450 N/mm ²	
K2	Gusseisen Cast iron	EN-GJS-600-3 (GGG60), EN-GJS-700-2 (GGG70)	0.7060, 0.7070	> 450 N/mm ²	
S1	Titan & Titanlegierungen Titanium & titanium alloys	TiAl6V4	3.7165		
S2	Warmfeste Legierungen High Temp alloys	Inconel; NIMONIC		800 – 1700 N/mm ²	
N1	Alu-Knetlegierungen Wrought aluminum alloys	AlMg1	3.3315		Si < 9%
N2	Alu-Gusslegierungen Aluminum cast alloys	G-Alsi12	3.2581		Si > 9%
H1	Gehärtete Stähle Hardened steels				45 – 55 HRC
H2	Gehärtete Stähle Hardened steels				> 55 HRC

1000	R	1.00	A	A	0001	KR
Durchmesser Diameter	Schneidkantenübergang Cutting edge transition	Größe Übergang Size transition	Material Material	Beschichtung Coating	Sondernummer Special number	Kühlung Cooling
1200- Metrisch Metric 1/2Z- Inch Inch	S- Scharfkantig Sharp cutting edge C- Fase Chamfer R- Radius Radius W- Fasenwinkel Chamfer angle	1.00- Metrisch Metric .03- Inch Inch 90- Fasenwinkel Chamfer angle 60- Fasenwinkel Chamfer angle 120- Fasenwinkel Chamfer angle	A- HF10 h5 D- HF10 h6	A- HAIMER-UNI C- HAIMER-ALU T- HAIMER-HARD - keine none	0000 - 9999	KR- Kühlung radial Cooling radial KZ- Kühlung zentral Cooling central KS- Kühlung sonder Cooling special

E1012NN/E1012NL – HAIMER MILL MULTIFUNKTIONSFÄSER/MULTIFUNCTION END MILL

Schnittdaten/Cutting data

HAIMER Werkstoff Gruppen HAIMER Material groups	Beispiel Werkstoffe Example material	Werkstoff Information Material information				Schruppen Vc (m/min) Roughing Vc (m/min)	Schlichten Vc (m/min) Finishing Vc (m/min)
		DIN DIN	Werkstoffnr. Material no.	Zugfestigkeit Tensile strength	Inhalt/Härte Content/ Hardness		
P1	Allg. Bau-, Einsatzstähle General construction steels	S235JR (RST37-2), E295 (St 50-2), C45	1.0038, 1.0050, 1.0503	≤ 800 N/mm ²	bis 25 HRC up to 25 HRC	160 – 220	220 – 280
P2	Werkzeug-/Vergütungsstähle Heat treated steels	X38CrMoV5-3, X153CrMoV12, X100CrMoV5, 42CrMo4	1.2367, 1.2379, 1.2363, 1.7225	> 800 N/mm ²	bis 45 HRC up to 45 HRC	120 – 160	160 – 200
M1	Rostfreie Stähle Stainless steels	X8CrNiS18-9, X5CrNi18-10, X46Cr13	1.4305, 1.4301, 1.4034	≤ 650 N/mm ²		80 – 120	120 – 160
M2	Rostfreie Stähle Stainless steels	X6CrNiMoTi17-12-2, X2CrNiMo17-12-2, X4CrNiMo16-5-1	1.4571, 1.4404, 1.4418	> 650 N/mm ²		60 – 90	90 – 120
K1	Gusseisen Cast iron	EN-GJL200 (GG20), EN-GJLZ (GG40), EN-GJS-400-15 (GGG40)	0.6020, 0.6040, 0.7040	≤ 450 N/mm ²		120 – 180	180 – 240
K2	Gusseisen Cast iron	EN-GJS-600-3 (GGG60), EN-GJS-700-2 (GGG70)	0.7060, 0.7070	> 450 N/mm ²		80 – 160	160 – 220
S1	Titan & Titanlegierungen Titanium & titanium alloys	TiAl6V4	3.7165			40 – 80	40 – 80
S2	Wärmefeste Legierungen High Temp alloys	Inconel; NIMONIC		800 – 1700 N/mm ²		30 – 40	30 – 40
N1	Alu-Knetlegierungen Wrought aluminum alloys	AlMg1	3.3315		Si < 9%	500 – 900	500 – 900
N2	Alu-Gusslegierungen Aluminum cast alloys	G-Alsi12	3.2581		Si > 9%	120 – 350	120 – 350
H1	Gehärtete Stähle Hardened steels				45 – 55 HRC	40 – 60	60 – 80

Schnittdaten dienen als Richtwerte und müssen dem Bearbeitungsumfeld angepasst werden.
 Cutting data are reference values and need to be adjusted according to the application area.

Vorschubtable f _z (mm/Zahn) abhängig von D1 und Schnittbreite a _e / Feed per tooth (mm/tooth) in relation with D1 and cutting width a _e				
	∅ 4	∅ 6	∅ 8	∅ 10
f _z	0,01 – 0,04	0,015 – 0,06	0,02 – 0,08	0,03 – 0,10

E1012NN/E1012NL – HAIMER MILL MULTIFUNKTIONSFRÄSER/MULTIFUNCTION END MILL

Technische Daten und Produkteigenschaften/Technical data and Product characteristics



Eigenschaften Characteristics

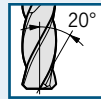

Anwendung Application

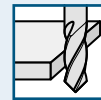
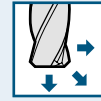

Kühlung Coolant

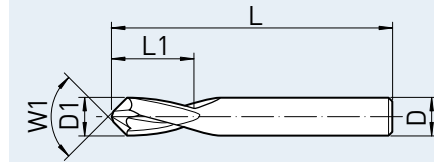

≤0,005

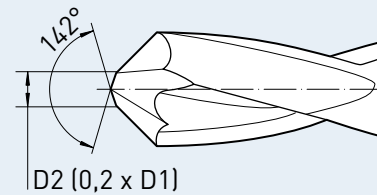

Feingewuchtet/Fine balanced

Material – Merkmale/Material – characteristics

Haupteinsatz
Main Material



auch geeignet für
also suitable for



- Konuswinkel 60/90/120/142°
- Zentrierspitze
- Multifunktionales Werkzeug
- Umfangsschneidend

- Cone angle 60/90/120/142°
- Center spot
- Multi functional tool
- Circumference cutting

Artikel-Code Article-Code	Qualität Quality	D1 (h9) D1 (h9) [mm]	Fasenfräser Chamfer	W1 W1	L1 max. L1 max. [mm]	L L [mm]	D (h6) D (h6) [mm]	Schaft Shank
E1012NNH0400W60..	DA	4,00	W	60°	11	51	4,00	HA
E1012NNH0400W90..	DA	4,00	W	90°	11	51	4,00	HA
E1012NNH0400W120..	DA	4,00	W	120°	11	51	4,00	HA
E1012NNH0400W142..	DA	4,00	W	142°	11	51	4,00	HA
E1012NLH0600W60..	DA	6,00	W	60°	13	66	6,00	HA
E1012NLH0600W90..	DA	6,00	W	90°	13	66	6,00	HA
E1012NLH0600W120..	DA	6,00	W	120°	13	66	6,00	HA
E1012NLH0600W142..	DA	6,00	W	142°	13	66	6,00	HA
E1012NLH0800W60..	DA	8,00	W	60°	19	79	8,00	HA
E1012NLH0800W90..	DA	8,00	W	90°	19	79	8,00	HA
E1012NLH0800W120..	DA	8,00	W	120°	19	79	8,00	HA
E1012NLH0800W142..	DA	8,00	W	142°	19	79	8,00	HA
E1012NLH1000W60..	DA	10,00	W	60°	22	89	10,00	HA
E1012NLH1000W90..	DA	10,00	W	90°	22	89	10,00	HA
E1012NLH1000W120..	DA	10,00	W	120°	22	89	10,00	HA
E1012NLH1000W142..	DA	10,00	W	142°	22	89	10,00	HA

Bestellnummer = Artikel-Code + Qualität.
Order No. = Article Code + Quality.

E1014UN – HAIMER MILL VIERTELKREISFRÄSER/QUADRANT END MILL

Schnittdaten/Cutting data

HAIMER Werkstoff Gruppen HAIMER Material groups	Beispiel Werkstoffe Example material	Werkstoff Information Material information				Schruppen Vc (m/min) Roughing Vc (m/min)	Schlichten Vc (m/min) Finishing Vc (m/min)
		DIN DIN	Werkstoffnr. Material no.	Zugfestigkeit Tensile strength	Inhalt/Härte Content/ Hardness		
P1	Allg. Bau-, Einsatzstähle General construction steels	S235JR (RST37-2), E295 (St 50-2), C45	1.0038, 1.0050, 1.0503	≤ 800 N/mm ²	bis 25 HRC up to 25 HRC	160 – 220	220 – 280
P2	Werkzeug-/Vergütungsstähle Heat treated steels	X38CrMoV5-3, X153CrMoV12, X100CrMoV5, 42CrMo4	1.2367, 1.2379, 1.2363, 1.7225	> 800 N/mm ²	bis 45 HRC up to 45 HRC	120 – 160	160 – 200
M1	Rostfreie Stähle Stainless steels	X8CrNiS18-9, X5CrNi18-10, X46Cr13	1.4305, 1.4301, 1.4034	≤ 650 N/mm ²		80 – 120	120 – 160
M2	Rostfreie Stähle Stainless steels	X6CrNiMoTi17-12-2, X2CrNiMo17-12-2, X4CrNiMo16-5-1	1.4571, 1.4404, 1.4418	> 650 N/mm ²		60 – 90	90 – 120
K1	Gusseisen Cast iron	EN-GJL200 (GG20), EN-GJLZ (GG40), EN-GJS-400-15 (GGG40)	0.6020, 0.6040, 0.7040	≤ 450 N/mm ²		120 – 180	180 – 240
K2	Gusseisen Cast iron	EN-GJS-600-3 (GGG60), EN-GJS-700-2 (GGG70)	0.7060, 0.7070	> 450 N/mm ²		80 – 160	160 – 220
S1	Titan & Titanlegierungen Titanium & titanium alloys	TiAl6V4	3.7165			40 – 80	40 – 80
S2	Wärmefeste Legierungen High Temp alloys	Inconel; NIMONIC		800 – 1700 N/mm ²		30 – 40	30 – 40
N1	Alu-Knetlegierungen Wrought aluminum alloys	AlMg1	3.3315		Si < 9%	500 – 900	500 – 900
N2	Alu-Gusslegierungen Aluminum cast alloys	G-Alsi12	3.2581		Si > 9%	120 – 350	120 – 350
H1	Gehärtete Stähle Hardened steels				45 – 55 HRC	40 – 60	60 – 80

Schnittdaten dienen als Richtwerte und müssen dem Bearbeitungsumfeld angepasst werden.
Cutting data are reference values and need to be adjusted according to the application area.

Vorschubtable f_z (mm/Zahn) abhängig von D1 und Schnittbreite a_e / Feed per tooth (mm/tooth) in relation with D1 and cutting width a_e

	∅ 6	∅ 8	∅ 10
f _z	0,015 – 0,06	0,02 – 0,08	0,03 – 0,10

E1014UN – HAIMER MILL VIERTELKREISFRÄSER/QUADRANT END MILL

Technische Daten und Produkteigenschaften/Technical data and Product characteristics



Eigenschaften Characteristics



Anwendung Application



Kühlung Coolant

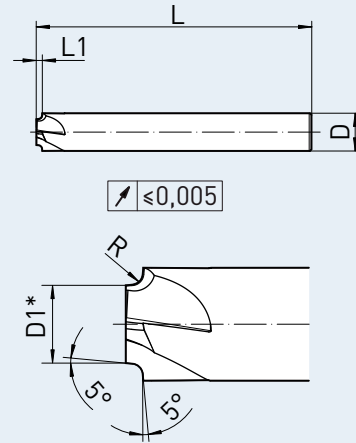

Feingewuchtet/Fine balanced
* nicht zentrumschneidender Durchmesser
* diameter not center cutting
Ausgenommen Weldonenschaft/Except Weldon shank

Material – Merkmale/Material – characteristics

Haupteinsatz
Main Material



auch geeignet für
also suitable for



- Zur Konturverrundung
- 5° tangentiale Freisetzung
- Positiver Spanwinkel ohne Profilverzerrung

- For contour rounding
- 5° tangential release
- Positive rake angle without profile displacement

Artikel-Code Article-Code	Qualität Quality	D1 D1 [mm]	Schneidecke Cutting edge	Eckradius Edge radius [mm]	L1 max. L1 max. [mm]	L L [mm]	D (h6) D (h6) [mm]	Schaft Shank
E1014UNH0600R0.25..	DA	5,0	R	0,25	0,50	58	6	HA
E1014UNH0600R0.50..	DA	4,5	R	0,50	0,75	58	6	HA
E1014UNH0800R0.75..	DA	6,0	R	0,75	1,00	64	8	HA
E1014UNH0800R1.00..	DA	5,0	R	1,00	1,50	64	8	HA
E1014UNH1000R1.50..	DA	6,0	R	1,50	2,00	73	10	HA
E1014UNH1000R2.00..	DA	5,0	R	2,00	2,50	73	10	HA

Bestellnummer = Artikel-Code + Qualität.
Order No. = Article Code + Quality.

E1014UN/E1016UN – HAIMER MILL ENTGRATFRÄSER/CHAMFERING END MILL

Schnittdaten/Cutting data

HAIMER Werkstoff Gruppen HAIMER Material groups	Beispiel Werkstoffe Example material	Werkstoff Information Material information				Schruppen Vc (m/min) Roughing Vc (m/min)	Schlichten Vc (m/min) Finishing Vc (m/min)
		DIN DIN	Werkstoffnr. Material no.	Zugfestigkeit Tensile strength	Inhalt/Härte Content/ Hardness		
P1	Allg. Bau-, Einsatzstähle General construction steels	S235JR (RST37-2), E295 (St 50-2), C45	1.0038, 1.0050, 1.0503	≤ 800 N/mm ²	bis 25 HRC up to 25 HRC	160 – 220	220 – 280
P2	Werkzeug/ Vergütungsstähle Heat treated steels	X38CrMoV5-3, X153CrMoV12, X100CrMoV5, 42CrMo4	1.2367, 1.2379, 1.2363, 1.7225	> 800 N/mm ²	bis 45 HRC up to 45 HRC	120 – 160	160 – 200
M1	Rostfreie Stähle Stainless steels	X8CrNiS18-9, X5CrNi18-10, X46Cr13	1.4305, 1.4301, 1.4034	≤ 650 N/mm ²		80 – 120	120 – 160
M2	Rostfreie Stähle Stainless steels	X6CrNiMoTi17-12-2, X2CrNiMo17-12-2, X4CrNiMo16-5-1	1.4571, 1.4404, 1.4418	> 650 N/mm ²		60 – 90	90 – 120
K1	Gusseisen Cast iron	EN-GJL200 (GG20), EN-GJLZ (GG40), EN- GJS-400-15 (GGG40)	0.6020, 0.6040, 0.7040	≤ 450 N/mm ²		120 – 180	180 – 240
K2	Gusseisen Cast iron	EN-GJS-600-3 (GGG60), EN-GJS-700-2 (GGG70)	0.7060, 0.7070	> 450 N/mm ²		80 – 160	160 – 220
S1	Titan & Titanlegierungen Titanium & titanium alloys	TiAl6V4	3.7165			40 – 80	40 – 80
S2	Wärmefeste Legierungen High Temp alloys	Inconel; NIMONIC		800 – 1700 N/mm ²		30 – 40	30 – 40
N1	Alu-Knetlegierungen Wrought aluminum alloys	AlMg1	3.3315		Si < 9%	500 – 900	500 – 900
N2	Alu-Gusslegierungen Aluminum cast alloys	G-Alsi12	3.2581		Si > 9%	120 – 350	120 – 350
H1	Gehärtete Stähle Hardened steels				45 – 55 HRC	40 – 60	60 – 80

Schnittdaten dienen als Richtwerte und müssen dem Bearbeitungsumfeld angepasst werden.
Cutting data are reference values and need to be adjusted according to the application area.

Vorschubtable f_z (mm/Zahn) abhängig von D1 und Schnittbreite a_e / Feed per tooth (mm/tooth) in relation with D1 and cutting width a_e

	∅ 4	∅ 6	∅ 8	∅ 10
f _z	0,01 – 0,04	0,015 – 0,06	0,02 – 0,08	0,03 – 0,10

E1014UN/E1016UN – HAIMER MILL ENTGRATFRÄSER/CHAMFERING END MILL

Technische Daten und Produkteigenschaften/Technical data and Product characteristics



Eigenschaften Characteristics

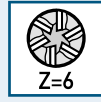

Anwendung Application

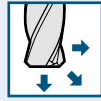

Kühlung Coolant

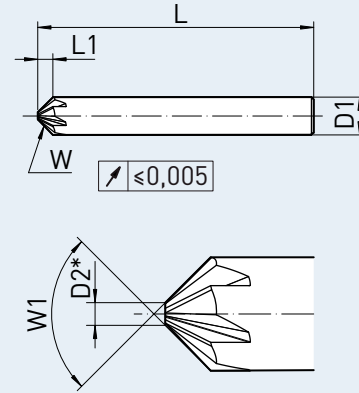

Feingewuchtet/Fine balanced
* nicht zentrumschneidender Durchmesser
* diameter not center cutting
Ausgenommen Weldonenschaft/Except Weldon shank

Material – Merkmale/Material – characteristics

Haupteinsatz
Main Material



auch geeignet für
also suitable for



- Konuswinkel 60/90/120°
- Spitze plan geschliffen
- Multifunktionales Werkzeug
- Gerade genutet



- Cone angle 60/90/120°
- Honed tip plan
- Multi functional tool
- Straight fluted

Artikel-Code Article-Code	Qualität Quality	D1 (h6) D1 (h6) [mm]	Fasenfräser Chamfer	Winkel W1 Angle W1	L1 max. L1 max. [mm]	L L [mm]	D2 D2 [mm]	Schaft Shank
E1014UNH0400W60..	DA	4,00	W	60°	2,8	51	0,8	HA
E1014UNH0400W90..	DA	4,00	W	90°	1,6	51	0,8	HA
E1014UNH0400W120..	DA	4,00	W	120°	0,9	51	0,8	HA
E1016UNH0600W60..	DA	6,00	W	60°	4,2	51	0,8	HA
E1016UNH0600W90..	DA	6,00	W	90°	2,4	58	1,2	HA
E1016UNH0600W120..	DA	6,00	W	120°	1,3	58	1,2	HA
E1016UNH0800W60..	DA	8,00	W	60°	5,5	64	1,6	HA
E1016UNH0800W90..	DA	8,00	W	90°	3,2	64	1,6	HA
E1016UNH0800W120..	DA	8,00	W	120°	1,8	64	1,6	HA
E1016UNH1000W60..	DA	10,00	W	60°	6,9	73	2,0	HA
E1016UNH1000W90..	DA	10,00	W	90°	4	73	2,0	HA
E1016UNH1000W120..	DA	10,00	W	120°	2,3	73	2,0	HA

Bestellnummer = Artikel-Code + Qualität.
Order No. = Article Code + Quality.

F1003NN – HAIMER MILL Power Series SCHARFKANTIG/SHARP CUTTING EDGE

Schnittdaten/Cutting data

HAIMER Werkstoff Gruppen HAIMER Material groups	Beispiel Werkstoffe Example material	Werkstoffnr. Material no.	Werkstoff Information Material information		Schnittbreite/Cutting width			
			Zugfestigkeit Tensile strength	Inhalt/Härte Content/ Hardness				
					Schnittgeschwindigkeit Vc (m/min) Cutting speed Vc (m/min)			
P1	Allg. Bau-, Einsatzstähle General construction steels	S235JR (RST37-2), E295 (St 50-2), C45	1.0038, 1.0050, 1.0503	≤ 800 N/mm ²	bis 25 HRC up to 25 HRC	170 – 200	210 – 240	250 – 270
P2	Werkzeug/Vergütungsstähle Heat treated steels	X38CrMoV5-3, X153CrMoV12, X100CrMoV5, 42CrMo4	1.2367, 1.2379, 1.2363, 1.7225	> 800 N/mm ²	bis 45 HRC up to 45 HRC	90 – 110	110 – 130	130 – 150
M1	Rostfreie Stähle Stainless steels	X8CrNiS18-9, X5CrNi18-10, X46Cr13	1.4305, 1.4301, 1.4034	≤ 650 N/mm ²		–	–	55 – 65
M2	Rostfreie Stähle Stainless steels	X6CrNiMoTi17-12-2, X2CrNiMo17-12-2, X4CrNiMo16-5-1	1.4571, 1.4404, 1.4418	> 650 N/mm ²		–	–	40 – 50
K1	Gusseisen Cast iron	EN-GJL200 (GG20), EN-GJLZ (GG40), EN-GJS-400-15 (GGG40)	0.6020, 0.6040, 0.7040	≤ 450 N/mm ²		110 – 130	130 – 150	200 – 220
K2	Gusseisen Cast iron	EN-GJS-600-3 (GGG60), EN-GJS-700-2 (GGG70)	0.7060, 0.7070	> 450 N/mm ²		90 – 110	110 – 130	160 – 180
S1	Titan & Titanlegierungen Titanium & titanium alloys	TiAl6V4	3.7165			60 – 80	60 – 80	60 – 80
S2	Warmfeste Legierungen High Temp alloys	Inconel; NIMONIC		800 – 1700 N/mm ²		30 – 40	30 – 40	30 – 40
N1	Alu-Knetlegierungen Wrought aluminum alloys	AlMg1	3.3315		Si < 9%	120 – 240	120 – 240	120 – 240
N2	Alu-Gusslegierungen Aluminum cast alloys	G-Alsi12	3.2581		Si > 9%	120 – 240	120 – 240	120 – 240
H1	Gehärtete Stähle Hardened steels				45 – 55 HRC	40 – 60	60 – 80	60 – 80

Schnittdaten dienen als Richtwerte und müssen dem Bearbeitungsumfeld angepasst werden.
Cutting data are reference values and need to be adjusted according to the application area.

Vorschubtable f _z (mm/Zahn) abhängig von D1 und Schnittbreite ae / Feed per tooth (mm/tooth) in relation with D1 and cutting width ae												
ae	ø 2	ø 3	ø 4	ø 5	ø 6	ø 8	ø 10	ø 12	ø 14	ø 16	ø 18	ø 20
bis/to 50% ø	0,012	0,018	0,024	0,030	0,036	0,048	0,060	0,072	0,084	0,096	0,108	0,120
100% ø	0,010	0,015	0,020	0,025	0,030	0,040	0,050	0,060	0,070	0,080	0,090	0,100
	0,002	0,003	0,004	0,005	0,006	0,008	0,010	0,012	0,014	0,016	0,018	0,020

F1003NN – HAIMER MILL Power Series SCHARFKANTIG/SHARP CUTTING EDGE

Technische Daten und Produkteigenschaften/Technical data and Product characteristics



Wahlweise / Optional:

- Glattschaft DIN 6535-HA / Straight shank DIN 6535-HA
- Safe-Lock Schaft (S-λ) / Safe-Lock shank (S-λ)
- Weldonschaft ähnlich DIN 6535-HB / Weldon shank similar DIN 6535-HB

* = H

* = L

* = B

Eigenschaften Characteristics

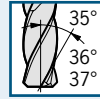

Anwendung Application

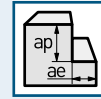
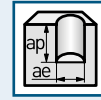
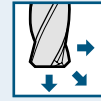

Kühlung Coolant

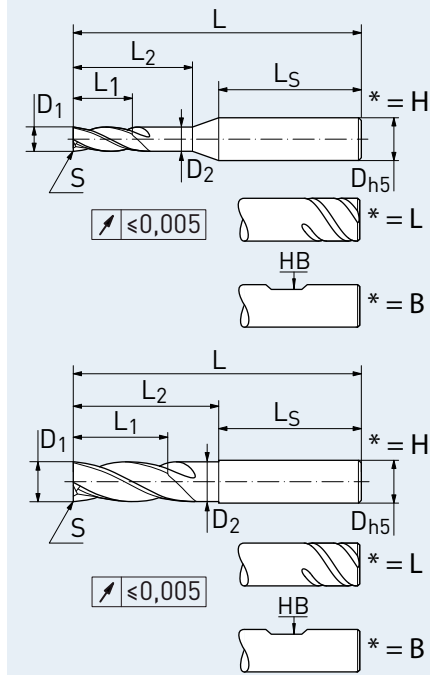

Feingewuchtet/Fine balanced
Ausgenommen Weldonschaft/Except Weldon shank

Material – Merkmale/Material – characteristics

Haupteinsatz
Main Material



auch geeignet für
also suitable for



- Halsabsatz für längere Eingriffstiefe
- Zentrumschneide
- Ungleiche Schneidenteilung
- Polierte Span- und Freiflächen



- Neck for higher cutting depth
- Center cutting
- Unequal cutting edge
- Polished flute and relief

Artikel-Code Article-Code	Qualität Quality	D1 (h9) D1 (h9) [mm]	Schneidecke Cutting edge	L1 max. L1 max. [mm]	L L [mm]	L2 L2 [mm]	D2 D2 [mm]	D (h5) D (h5) [mm]	LS LS [mm]	Schaft Shank
F1003NN*0200S..	AA	2,00	S	7	58	9	1,9	6	44,3	HA/S-λ/HB
F1003NN*0300S..	AA	3,00	S	8	58	10	2,9	6	44,0	HA/S-λ/HB
F1003NN*0400S..	AA	4,00	S	11	58	15	3,8	6	40,0	HA/S-λ/HB
F1003NN*0500S..	AA	5,00	S	13	58	18	4,8	6	37,875	HA/S-λ/HB
F1003NN*0600S..	AA	6,00	S	13	58	20	5,7	6	36,5	HA/S-λ/HB
F1003NN*0800S..	AA	8,00	S	19	64	26	7,6	8	36,5	HA/S-λ/HB
F1003NN*1000S..	AA	10,00	S	22	73	30,5	9,5	10	40,5	HA/S-λ/HB
F1003NN*1200S..	AA	12,00	S	26	84	36,5	11,4	12	45,5	HA/S-λ/HB
F1003NN*1400S..	AA	14,00	S	26	84	36,5	13,3	14	45,5	HA/S-λ/HB
F1003NN*1600S..	AA	16,00	S	32	93	42,5	15,2	16	48,5	HA/S-λ/HB
F1003NN*1800S..	AA	18,00	S	32	93	42,5	17,1	18	48,5	HA/S-λ/HB
F1003NN*2000S..	AA	20,00	S	38	105	52	19	20	50,5	HA/S-λ/HB

* = L - Safe-Lock / H - Glattschaft / B - Weldonschaft. Bestellnummer = Artikel-Code + Qualität.
* = L - Safe-Lock / H - Straight shank / B - Weldon shank. Order No. = Article Code + Quality.

F1004NN – HAIMER MILL Power Series FASE/CHAMFER

Schnittdaten/Cutting data

HAIMER Werkstoff Gruppen HAIMER Material groups	Beispiel Werkstoffe Example material	Werkstoffnr. Material no.	Werkstoff Information Material information		Schnittbreite/Cutting width			
			Zugfestigkeit Tensile strength	Inhalt/Härte Content/ Hardness				
					Schnittgeschwindigkeit Vc (m/min) Cutting speed Vc (m/min)			
P1	Allg. Bau-, Einsatzstähle General construction steels	S235JR (RST37-2), E295 (St 50-2), C45	1.0038, 1.0050, 1.0503	≤ 800 N/mm ²	bis 25 HRC up to 25 HRC	170 – 200	210 – 240	250 – 270
P2	Werkzeug/Vergütungsstähle Heat treated steels	X38CrMoV5-3, X153CrMoV12, X100CrMoV5, 42CrMo4	1.2367, 1.2379, 1.2363, 1.7225	> 800 N/mm ²	bis 45 HRC up to 45 HRC	90 – 110	110 – 130	130 – 150
M1	Rostfreie Stähle Stainless steels	X8CrNiS18-9, X5CrNi18-10, X46Cr13	1.4305, 1.4301, 1.4034	≤ 650 N/mm ²		–	–	55 – 65
M2	Rostfreie Stähle Stainless steels	X6CrNiMoTi17-12-2, X2CrNiMo17-12-2, X4CrNiMo16-5-1	1.4571, 1.4404, 1.4418	> 650 N/mm ²		–	–	40 – 50
K1	Gusseisen Cast iron	EN-GJL200 (GG20), EN-GJLZ (GG40), EN-GJS-400-15 (GGG40)	0.6020, 0.6040, 0.7040	≤ 450 N/mm ²		110 – 130	130 – 150	200 – 220
K2	Gusseisen Cast iron	EN-GJS-600-3 (GGG60), EN-GJS-700-2 (GGG70)	0.7060, 0.7070	> 450 N/mm ²		90 – 110	110 – 130	160 – 180
S1	Titan & Titanlegierungen Titanium & titanium alloys	TiAl6V4	3.7165			60 – 80	60 – 80	60 – 80
S2	Warmfeste Legierungen High Temp alloys	Inconel; NIMONIC		800 – 1700 N/mm ²		30 – 40	30 – 40	30 – 40
N1	Alu-Knetlegierungen Wrought aluminum alloys	AlMg1	3.3315		Si < 9%	120 – 240	120 – 240	120 – 240
N2	Alu-Gusslegierungen Aluminum cast alloys	G-Alsi12	3.2581		Si > 9%	120 – 240	120 – 240	120 – 240
H1	Gehärtete Stähle Hardened steels				45 – 55 HRC	40 – 60	60 – 80	60 – 80

Schnittdaten dienen als Richtwerte und müssen dem Bearbeitungsumfeld angepasst werden.
Cutting data are reference values and need to be adjusted according to the application area.

Vorschubtable f _z (mm/Zahn) abhängig von D1 und Schnittbreite ae / Feed per tooth (mm/tooth) in relation with D1 and cutting width ae												
ae	ø 2	ø 3	ø 4	ø 5	ø 6	ø 8	ø 10	ø 12	ø 14	ø 16	ø 18	ø 20
bis/to 50% ø	0,012	0,018	0,024	0,030	0,036	0,048	0,060	0,072	0,084	0,096	0,108	0,120
100% ø	0,010	0,015	0,020	0,025	0,030	0,040	0,050	0,060	0,070	0,080	0,090	0,100
	0,002	0,003	0,004	0,005	0,006	0,008	0,010	0,012	0,014	0,016	0,018	0,020

F1004NN – HAIMER MILL Power Series FASE/CHAMFER

Technische Daten und Produkteigenschaften/Technical data and Product characteristics



Wahlweise / Optional:

- Glattschaft DIN 6535-HA / Straight shank DIN 6535-HA
- Safe-Lock Schaft (S-λ) / Safe-Lock shank (S-λ)
- Weldonschaft ähnlich DIN 6535-HB / Weldon shank similar DIN 6535-HB



* = H

* = L

* = B

Eigenschaften Characteristics

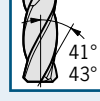

Anwendung Application

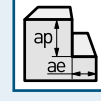
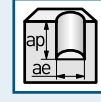
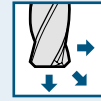

Kühlung Coolant

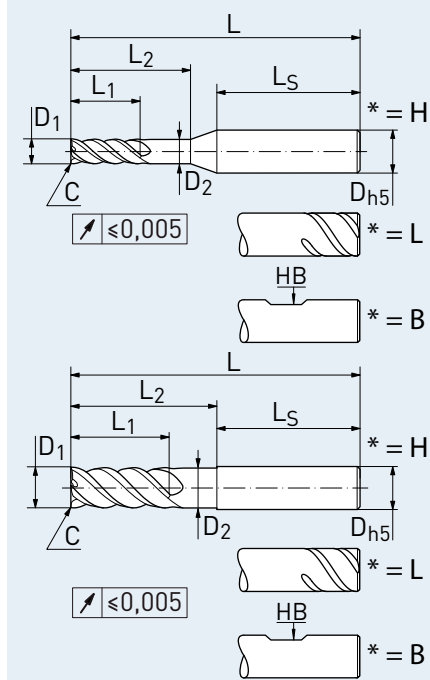

Feingewuchtet/Fine balanced
Ausgenommen Weldonschaft/Except Weldon shank

Material – Merkmale/Material – characteristics

Haupteinsatz
Main Material



auch geeignet für
also suitable for



- Halsabsatz für längere Eingriffstiefe
- Zentrumschneide
- Ungleiche Schneidenteilung
- Polierte Span- und Freiflächen



- Neck for higher cutting depth
- Center cutting
- Unequal cutting edge
- Polished flute and relief

Artikel-Code Article-Code	Qualität Quality	D1 (h9) D1 (h9) [mm]	Schneidecke Cutting edge	Größe Size [mm]	L1 max. L1 max. [mm]	L L [mm]	L2 L2 [mm]	D2 D2 [mm]	D (h5) D (h5) [mm]	LS LS [mm]	Schaft Shank
F1004NN*0200C..	AA	2,00	C	0,10	7	58	9	1,9	6	44,3	HA/S-λ/HB
F1004NN*0300C..	AA	3,00	C	0,10	8	58	10	2,9	6	44,0	HA/S-λ/HB
F1004NN*0400C..	AA	4,00	C	0,15	11	58	15	3,8	6	40,0	HA/S-λ/HB
F1004NN*0500C..	AA	5,00	C	0,20	13	58	18	4,8	6	37,875	HA/S-λ/HB
F1004NN*0600C..	AA	6,00	C	0,20	13	58	20	5,7	6	36,5	HA/S-λ/HB
F1004NN*0800C..	AA	8,00	C	0,20	19	64	26	7,6	8	36,5	HA/S-λ/HB
F1004NN*1000C..	AA	10,00	C	0,30	22	73	30,5	9,5	10	40,5	HA/S-λ/HB
F1004NN*1200C..	AA	12,00	C	0,30	26	84	36,5	11,4	12	45,5	HA/S-λ/HB
F1004NN*1400C..	AA	14,00	C	0,40	26	84	36,5	13,3	14	45,5	HA/S-λ/HB
F1004NN*1600C..	AA	16,00	C	0,50	32	93	42,5	15,2	16	48,5	HA/S-λ/HB
F1004NN*1800C..	AA	18,00	C	0,50	32	93	42,5	17,1	18	48,5	HA/S-λ/HB
F1004NN*2000C..	AA	20,00	C	0,60	38	105	52	19	20	50,5	HA/S-λ/HB

* = L - Safe-Lock / H - Glattschaft / B - Weldonschaft. Bestellnummer = Artikel-Code + Qualität.
* = L - Safe-Lock / H - Straight shank / B - Weldon shank. Order No. = Article Code + Quality.

F1004NN – HAIMER MILL Power Series ECKENRADIUS/CORNER RADIUS

Schnittdaten/Cutting data

HAIMER Werkstoff Gruppen HAIMER Material groups	Beispiel Werkstoffe Example material	Werkstoffnr. Material no.	Werkstoff Information Material information		Schnittbreite/Cutting width			
			Zugfestigkeit Tensile strength	Inhalt/Härte Content/ Hardness				
					Schnittgeschwindigkeit Vc (m/min) Cutting speed Vc (m/min)			
P1	Allg. Bau-, Einsatzstähle General construction steels	S235JR (RST37-2), E295 (St 50-2), C45	1.0038, 1.0050, 1.0503	≤ 800 N/mm ²	bis 25 HRC up to 25 HRC	170 – 200	210 – 240	250 – 270
P2	Werkzeug/ Vergütungsstähle Heat treated steels	X38CrMoV5-3, X153CrMoV12, X100CrMoV5, 42CrMo4	1.2367, 1.2379, 1.2363, 1.7225	> 800 N/mm ²	bis 45 HRC up to 45 HRC	90 – 110	110 – 130	130 – 150
M1	Rostfreie Stähle Stainless steels	X8CrNiS18-9, X5CrNi18-10, X46Cr13	1.4305, 1.4301, 1.4034	≤ 650 N/mm ²		–	–	55 – 65
M2	Rostfreie Stähle Stainless steels	X6CrNiMoTi17-12-2, X2CrNiMo17-12-2, X4CrNiMo16-5-1	1.4571, 1.4404, 1.4418	> 650 N/mm ²		–	–	40 – 50
K1	Gusseisen Cast iron	EN-GJL200 (GG20), EN-GJLZ (GG40), EN-GJS-400-15 (GGG40)	0.6020, 0.6040, 0.7040	≤ 450 N/mm ²		110 – 130	130 – 150	200 – 220
K2	Gusseisen Cast iron	EN-GJS-600-3 (GGG60), EN-GJS-700-2 (GGG70)	0.7060, 0.7070	> 450 N/mm ²		90 – 110	110 – 130	160 – 180
S1	Titan & Titanlegierungen Titanium & titanium alloys	TiAl6V4	3.7165			60 – 80	60 – 80	60 – 80
S2	Warmfeste Legierungen High Temp alloys	Inconel; NIMONIC		800 – 1700 N/mm ²		30 – 40	30 – 40	30 – 40
N1	Alu-Knetlegierungen Wrought aluminum alloys	AlMg1	3.3315		Si < 9%	120 – 240	120 – 240	120 – 240
N2	Alu-Gusslegierungen Aluminum cast alloys	G-Alsi12	3.2581		Si > 9%	120 – 240	120 – 240	120 – 240
H1	Gehärtete Stähle Hardened steels				45 – 55 HRC	40 – 60	60 – 80	60 – 80

Schnittdaten dienen als Richtwerte und müssen dem Bearbeitungsumfeld angepasst werden.
Cutting data are reference values and need to be adjusted according to the application area.

Vorschubtable f _z (mm/Zahn) abhängig von D1 und Schnittbreite ae / Feed per tooth (mm/tooth) in relation with D1 and cutting width ae												
ae	ø 2	ø 3	ø 4	ø 5	ø 6	ø 8	ø 10	ø 12	ø 14	ø 16	ø 18	ø 20
bis/to 50% ø	0,012	0,018	0,024	0,030	0,036	0,048	0,060	0,072	0,084	0,096	0,108	0,120
100% ø	0,010	0,015	0,020	0,025	0,030	0,040	0,050	0,060	0,070	0,080	0,090	0,100
	0,002	0,003	0,004	0,005	0,006	0,008	0,010	0,012	0,014	0,016	0,018	0,020

F1004NN – HAIMER MILL Power Series ECKENRADIUS/CORNER RADIUS

Technische Daten und Produkteigenschaften/Technical data and Product characteristics



Wahlweise / Optional:

- Glattschaft DIN 6535-HA / Straight shank DIN 6535-HA
- Safe-Lock Schaft (S-λ) / Safe-Lock shank (S-λ)
- Weldonschaft ähnlich DIN 6535-HB / Weldon shank similar DIN 6535-HB



* = H

* = L

* = B

Eigenschaften Characteristics

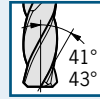

Anwendung Application

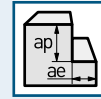
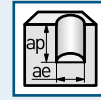
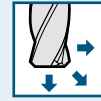

Kühlung Coolant

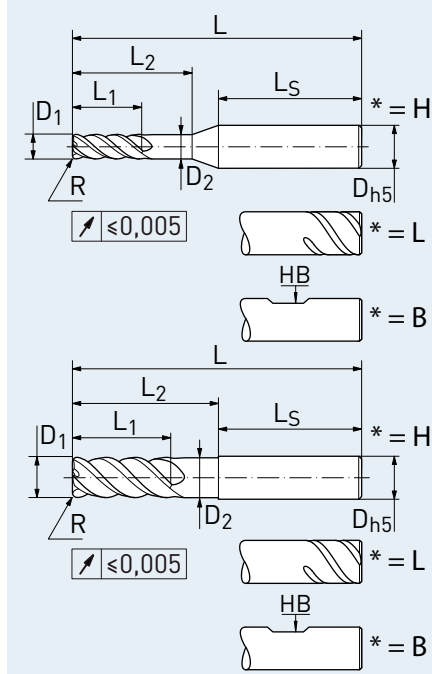

Feingewuchtet/Fine balanced
Ausgenommen Weldonschaft/Except Weldon shank

Material – Merkmale/Material – characteristics

Haupteinsatz
Main Material



auch geeignet für
also suitable for



- Halsabsatz für längere Eingriffstiefe
- Zentrumschneide
- Ungleiche Schneidenteilung
- Polierte Span- und Freiflächen

- Neck for higher cutting depth
- Center cutting
- Unequal cutting edge
- Polished flute and relief

Artikel-Code Article-Code	Qualität Quality	D1 (h9) D1 (h9) [mm]	Schneidecke Cutting edge	Größe Size [mm]	L1 max. L1 max. [mm]	L L [mm]	L2 L2 [mm]	D2 D2 [mm]	D (h5) D (h5) [mm]	LS LS [mm]	Schaft Shank
F1004NN*0200R0.20..	AA	2,00	R	0,20	7	58	9	1,9	6	44,3	HA/S-λ/HB
F1004NN*0300R0.20..	AA	3,00	R	0,20	8	58	10	2,9	6	44,0	HA/S-λ/HB
F1004NN*0300R0.30..	AA	3,00	R	0,30	8	58	10	2,9	6	44,0	HA/S-λ/HB
F1004NN*0400R0.20..	AA	4,00	R	0,20	11	58	15	3,8	6	40,0	HA/S-λ/HB
F1004NN*0400R0.30..	AA	4,00	R	0,30	11	58	15	3,8	6	40,0	HA/S-λ/HB
F1004NN*0400R0.40..	AA	4,00	R	0,40	11	58	15	3,8	6	40,0	HA/S-λ/HB
F1004NN*0400R0.50..	AA	4,00	R	0,50	11	58	15	3,8	6	40,0	HA/S-λ/HB
F1004NN*0500R0.30..	AA	5,00	R	0,30	13	58	18	4,8	6	37,875	HA/S-λ/HB
F1004NN*0500R0.50..	AA	5,00	R	0,50	13	58	18	4,8	6	37,875	HA/S-λ/HB
F1004NN*0500R1.00..	AA	5,00	R	1,00	13	58	18	4,8	6	37,875	HA/S-λ/HB
F1004NN*0600R0.20..	AA	6,00	R	0,20	13	58	20	5,7	6	36,5	HA/S-λ/HB
F1004NN*0600R0.30..	AA	6,00	R	0,30	13	58	20	5,7	6	36,5	HA/S-λ/HB

⇒ Weitere Artikel siehe nächste Seite/Turn page for more articles

* = L - Safe-Lock / H - Glattschaft / B - Weldonschaft. Bestellnummer = Artikel-Code + Qualität.
* = L - Safe-Lock / H - Straight shank / B - Weldon shank. Order No. = Article Code + Quality.

F1004NN – HAIMER MILL Power Series ECKENRADIUS/CORNER RADIUS

Technische Daten und Produkteigenschaften/Technical data and Product characteristics



Wahlweise / Optional:

- Glattschaft DIN 6535-HA / Straight shank DIN 6535-HA
- Safe-Lock Schaft (S-λ) / Safe-Lock shank (S-λ)
- Weldonschaft ähnlich DIN 6535-HB / Weldon shank similar DIN 6535-HB

Eigenschaften Characteristics	Anwendung Application	Kühlung Coolant

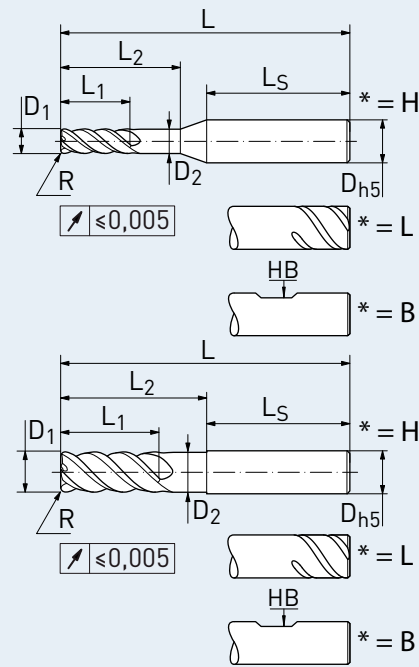

Feingewuchtet/Fine balanced
Ausgenommen Weldonschaft/Except Weldon shank

Material – Merkmale/Material – characteristics

Haupteinsatz
Main Material



auch geeignet für
also suitable for



- Halsabsatz für längere Eingriffstiefe
- Zentrumschneide
- Ungleiche Schneidenteilung
- Polierte Span- und Freiflächen

- Neck for higher cutting depth
- Center cutting
- Unequal cutting edge
- Polished flute and relief

Artikel-Code Article-Code	Qualität Quality	D1 (h9) D1 (h9) [mm]	Schneidecke Cutting edge	Größe Size [mm]	L1 max. L1 max. [mm]	L L [mm]	L2 L2 [mm]	D2 D2 [mm]	D (h5) D (h5) [mm]	LS LS [mm]	Schaft Shank
F1004NN*0600R0.50..	AA	6,00	R	0,50	13	58	20	5,7	6	36,5	HA/S-λ/HB
F1004NN*0600R1.00..	AA	6,00	R	1,00	13	58	20	5,7	6	36,5	HA/S-λ/HB
F1004NN*0600R1.50..	AA	6,00	R	1,50	13	58	20	5,7	6	36,5	HA/S-λ/HB
F1004NN*0800R0.20..	AA	8,00	R	0,20	19	64	26	7,6	8	36,5	HA/S-λ/HB
F1004NN*0800R0.30..	AA	8,00	R	0,30	19	64	26	7,6	8	36,5	HA/S-λ/HB
F1004NN*0800R0.50..	AA	8,00	R	0,50	19	64	26	7,6	8	36,5	HA/S-λ/HB
F1004NN*0800R1.00..	AA	8,00	R	1,00	19	64	26	7,6	8	36,5	HA/S-λ/HB
F1004NN*0800R1.50..	AA	8,00	R	1,50	19	64	26	7,6	8	36,5	HA/S-λ/HB
F1004NN*0800R2.00..	AA	8,00	R	2,00	19	64	26	7,6	8	36,5	HA/S-λ/HB
F1004NN*1000R0.30..	AA	10,00	R	0,30	22	73	30,5	9,5	10	40,5	HA/S-λ/HB

⇒ Weitere Artikel siehe nächste Seite/Turn page for more articles

* = L - Safe-Lock / H - Glattschaft / B - Weldonschaft. Bestellnummer = Artikel-Code + Qualität.
* = L - Safe-Lock / H - Straight shank / B - Weldon shank. Order No. = Article Code + Quality.

F1004NN – HAIMER MILL Power Series

ECKENRADIUS/CORNER RADIUS

Artikel-Code Article-Code	Qualität Quality	D1 (h9) D1 (h9) [mm]	Schneidecke Cutting edge	Größe Size [mm]	L1 max. L1 max. [mm]	L L [mm]	L2 L2 [mm]	D2 D2 [mm]	D (h5) D (h5) [mm]	LS LS [mm]	Schaft Shank
F1004NN*1000R0.50..	AA	10,00	R	0,50	22	73	30,5	9,5	10	40,5	HA/S-λ/HB
F1004NN*1000R1.00..	AA	10,00	R	1,00	22	73	30,5	9,5	10	40,5	HA/S-λ/HB
F1004NN*1000R1.50..	AA	10,00	R	1,50	22	73	30,5	9,5	10	40,5	HA/S-λ/HB
F1004NN*1000R2.00..	AA	10,00	R	2,00	22	73	30,5	9,5	10	40,5	HA/S-λ/HB
F1004NN*1200R0.30..	AA	12,00	R	0,30	26	84	36,5	11,4	12	45,5	HA/S-λ/HB
F1004NN*1200R0.50..	AA	12,00	R	0,50	26	84	36,5	11,4	12	45,5	HA/S-λ/HB
F1004NN*1200R1.00..	AA	12,00	R	1,00	26	84	36,5	11,4	12	45,5	HA/S-λ/HB
F1004NN*1200R1.50..	AA	12,00	R	1,50	26	84	36,5	11,4	12	45,5	HA/S-λ/HB
F1004NN*1200R2.00..	AA	12,00	R	2,00	26	84	36,5	11,4	12	45,5	HA/S-λ/HB
F1004NN*1200R3.00..	AA	12,00	R	3,00	26	84	36,5	11,4	12	45,5	HA/S-λ/HB
F1004NN*1200R4.00..	AA	12,00	R	4,00	26	84	36,5	11,4	12	45,5	HA/S-λ/HB
F1004NN*1400R0.50..	AA	14,00	R	0,50	26	84	36,5	13,3	14	45,5	HA/S-λ/HB
F1004NN*1400R1.00..	AA	14,00	R	1,00	26	84	36,5	13,3	14	45,5	HA/S-λ/HB
F1004NN*1400R2.00..	AA	14,00	R	2,00	26	84	36,5	13,3	14	45,5	HA/S-λ/HB
F1004NN*1600R0.30..	AA	16,00	R	0,30	32	93	42,5	15,2	16	48,5	HA/S-λ/HB
F1004NN*1600R0.50..	AA	16,00	R	0,50	32	93	42,5	15,2	16	48,5	HA/S-λ/HB
F1004NN*1600R0.80..	AA	16,00	R	0,80	32	93	42,5	15,2	16	48,5	HA/S-λ/HB
F1004NN*1600R1.00..	AA	16,00	R	1,00	32	93	42,5	15,2	16	48,5	HA/S-λ/HB
F1004NN*1600R1.50..	AA	16,00	R	1,50	32	93	42,5	15,2	16	48,5	HA/S-λ/HB
F1004NN*1600R2.00..	AA	16,00	R	2,00	32	93	42,5	15,2	16	48,5	HA/S-λ/HB
F1004NN*1600R3.00..	AA	16,00	R	3,00	32	93	42,5	15,2	16	48,5	HA/S-λ/HB
F1004NN*1600R4.00..	AA	16,00	R	4,00	32	93	42,5	15,2	16	48,5	HA/S-λ/HB
F1004NN*1800R0.50..	AA	18,00	R	0,50	32	93	42,5	17,1	18	48,5	HA/S-λ/HB
F1004NN*1800R1.00..	AA	18,00	R	1,00	32	93	42,5	17,1	18	48,5	HA/S-λ/HB
F1004NN*1800R2.00..	AA	18,00	R	2,00	32	93	42,5	17,1	18	48,5	HA/S-λ/HB
F1004NN*2000R0.30..	AA	20,00	R	0,30	38	105	52	19	20	50,5	HA/S-λ/HB
F1004NN*2000R0.50..	AA	20,00	R	0,50	38	105	52	19	20	50,5	HA/S-λ/HB
F1004NN*2000R0.80..	AA	20,00	R	0,80	38	105	52	19	20	50,5	HA/S-λ/HB
F1004NN*2000R1.00..	AA	20,00	R	1,00	38	105	52	19	20	50,5	HA/S-λ/HB
F1004NN*2000R1.50..	AA	20,00	R	1,50	38	105	52	19	20	50,5	HA/S-λ/HB
F1004NN*2000R2.00..	AA	20,00	R	2,00	38	105	52	19	20	50,5	HA/S-λ/HB
F1004NN*2000R3.00..	AA	20,00	R	3,00	38	105	52	19	20	50,5	HA/S-λ/HB
F1004NN*2000R4.00..	AA	20,00	R	4,00	38	105	52	19	20	50,5	HA/S-λ/HB

* = L - Safe-Lock / H - Glattschaft / B - Weldonschaft. Bestellnummer = Artikel-Code + Qualität.

* = L - Safe-Lock / H - Straight shank / B - Weldon shank. Order No. = Article Code + Quality.

F1005LL – HAIMER MILL Power Series FASE/CHAMFER

Schnittdaten/Cutting data

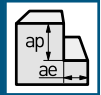
HAIMER Werkstoff Gruppen HAIMER Material groups	Beispiel Werkstoffe Example material	Werkstoffnr. Material no.	Werkstoff Information Material information		Schnittbreite Cutting width  ae = 5% D1 ap = L1 max.	
			Zugfestigkeit Tensile strength	Inhalt/Härte Content/ Hardness		
P1	Allg. Bau-, Einsatzstähle General construction steels	S235JR (RST37-2), E295 (St 50-2), C45	1.0038, 1.0050, 1.0503	≤ 800 N/mm ²	bis 25 HRC up to 25 HRC	250 – 270
P2	Werkzeug/ Vergütungsstähle Heat treated steels	X38CrMoV5-3, X153CrMoV12, X100CrMoV5, 42CrMo4	1.2367, 1.2379, 1.2363, 1.7225	> 800 N/mm ²	bis 45 HRC up to 45 HRC	130 – 150
M1	Rostfreie Stähle Stainless steels	X8CrNiS18-9, X5CrNi18-10, X46Cr13	1.4305, 1.4301, 1.4034	≤ 650 N/mm ²		55 – 65
M2	Rostfreie Stähle Stainless steels	X6CrNiMoTi17-12-2, X2CrNiMo17-12-2, X4CrNiMo16-5-1	1.4571, 1.4404, 1.4418	> 650 N/mm ²		40 – 50
K1	Gusseisen Cast iron	EN-GJL200 (GG20), EN-GJLZ (GG40), EN-GJS-400-15 (GGG40)	0.6020, 0.6040, 0.7040	≤ 450 N/mm ²		200 – 220
K2	Gusseisen Cast iron	EN-GJS-600-3 (GGG60), EN-GJS-700-2 (GGG70)	0.7060, 0.7070	> 450 N/mm ²		160 – 180
S1	Titan & Titanlegierungen Titanium & titanium alloys	TiAl6V4	3.7165			60 – 80
S2	Warmfeste Legierungen High Temp alloys	Inconel; NIMONIC		800 – 1700 N/mm ²		30 – 40
N1	Alu-Knetlegierungen Wrought aluminum alloys	AlMg1	3.3315		Si < 9%	120 – 240
N2	Alu-Gusslegierungen Aluminum cast alloys	G-Alsi12	3.2581		Si > 9%	120 – 240
H1	Gehärtete Stähle Hardened steels				45 – 55 HRC	60 – 80

Schnittdaten dienen als Richtwerte und müssen dem Bearbeitungsumfeld angepasst werden.
Cutting data are reference values and need to be adjusted according to the application area.

Vorschubtable f_z (mm/Zahn) abhängig von D1 und Schnittbreite ae / Feed per tooth (mm/tooth) in relation with D1 and cutting width ae

ae	ø 6	ø 8	ø 10	ø 12	ø 14	ø 16	ø 18	ø 20
bis/to 5% ø	0,051	0,068	0,085	0,102	0,119	0,136	0,153	0,170

F1005LL – HAIMER MILL Power Series FASE/CHAMFER

Technische Daten und Produkteigenschaften/Technical data and Product characteristics



Wahlweise / Optional:

- Glattschaft DIN 6535-HA / Straight shank DIN 6535-HA
- Safe-Lock Schaft (S-λ) / Safe-Lock shank (S-λ)
- Weldonschaft ähnlich DIN 6535-HB / Weldon shank similar DIN 6535-HB



* = H

* = L

* = B

Eigenschaften Characteristics

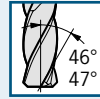
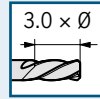

Anwendung Application

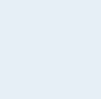
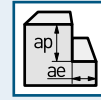

Kühlung Coolant

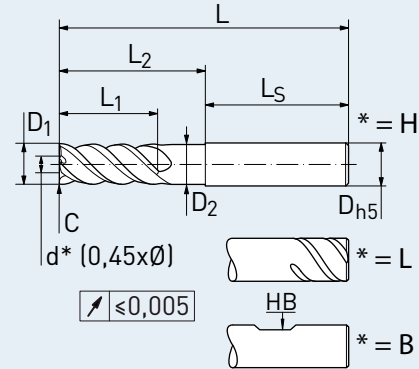

Feingewuchtet/Fine balanced
Ausgenommen Weldonschaft/Except Weldon shank
* nicht zentrumschneidender Durchmesser
* diameter not center cutting

Material – Merkmale/Material – characteristics

Haupteinsatz
Main Material



auch geeignet für
also suitable for



- Halsabsatz für längere Eingriffstiefe
- Ungleiche Schneidenteilung
- Schneidenlänge: lang
- Polierte Span- und Freiflächen

- Neck for higher cutting depth
- Unequal cutting edge
- Length of cutting edge: long
- Polished flute and relief



Artikel-Code Article-Code	Qualität Quality	D1 (h9) D1 (h9) [mm]	Schneidecke Cutting edge	Größe Size [mm]	L1 max. L1 max. [mm]	L L [mm]	L2 L2 [mm]	D2 D2 [mm]	D (h5) D (h5) [mm]	LS LS [mm]	Schaft Shank
F1005LL*0600C..	AA	6,00	C	0,20	18	62	24	5,7	6	36,5	HA/S-λ/HB
F1005LL*0800C..	AA	8,00	C	0,20	24	70	32	7,6	8	36,5	HA/S-λ/HB
F1005LL*1000C..	AA	10,00	C	0,30	30	82	40	9,5	10	40,5	HA/S-λ/HB
F1005LL*1200C..	AA	12,00	C	0,30	36	95	48	11,4	12	45,5	HA/S-λ/HB
F1005LL*1400C..	AA	14,00	C	0,40	42	105	56	13,3	14	46,5	HA/S-λ/HB
F1005LL*1600C..	AA	16,00	C	0,50	48	115	64	15,2	16	48,5	HA/S-λ/HB
F1005LL*1800C..	AA	18,00	C	0,50	54	123	72	17,1	18	48	HA/S-λ/HB
F1005LL*2000C..	AA	20,00	C	0,60	60	133	80	19,0	20	50,5	HA/S-λ/HB

* = L - Safe-Lock / H - Glattschaft / B - Weldonschaft. Bestellnummer = Artikel-Code + Qualität.

* = L - Safe-Lock / H - Straight shank / B - Weldon shank. Order No. = Article Code + Quality.

F1005NN – HAIMER MILL Power Series FASE/CHAMFER

Schnittdaten/Cutting data

HAIMER Werkstoff Gruppen HAIMER Material groups	Beispiel Werkstoffe Example material	Werkstoffnr. Material no.	Werkstoff Information Material information		Schnittbreite/Cutting width			
			Zugfestigkeit Tensile strength	Inhalt/Härte Content/ Hardness				
DIN DIN	DIN DIN				Schnittgeschwindigkeit Vc (m/min) Cutting speed Vc (m/min)			
P1	Allg. Bau-, Einsatzstähle General construction steels	S235JR (RST37-2), E295 (St 50-2), C45	1.0038, 1.0050, 1.0503	≤ 800 N/mm ²	bis 25 HRC up to 25 HRC	170 – 200	210 – 240	250 – 270
P2	Werkzeug/Vergütungsstähle Heat treated steels	X38CrMoV5-3, X153CrMoV12, X100CrMoV5, 42CrMo4	1.2367, 1.2379, 1.2363, 1.7225	> 800 N/mm ²	bis 45 HRC up to 45 HRC	90 – 110	110 – 130	130 – 150
M1	Rostfreie Stähle Stainless steels	X8CrNiS18-9, X5CrNi18-10, X46Cr13	1.4305, 1.4301, 1.4034	≤ 650 N/mm ²		–	–	55 – 65
M2	Rostfreie Stähle Stainless steels	X6CrNiMoTi17-12-2, X2CrNiMo17-12-2, X4CrNiMo16-5-1	1.4571, 1.4404, 1.4418	> 650 N/mm ²		–	–	40 – 50
K1	Gusseisen Cast iron	EN-GJL200 (GG20), EN-GJLZ (GG40), EN-GJS-400-15 (GGG40)	0.6020, 0.6040, 0.7040	≤ 450 N/mm ²		110 – 130	130 – 150	200 – 220
K2	Gusseisen Cast iron	EN-GJS-600-3 (GGG60), EN-GJS-700-2 (GGG70)	0.7060, 0.7070	> 450 N/mm ²		90 – 110	110 – 130	160 – 180
S1	Titan & Titanlegierungen Titanium & titanium alloys	TiAl6V4	3.7165			60 – 80	60 – 80	60 – 80
S2	Warmfeste Legierungen High Temp alloys	Inconel; NIMONIC		800 – 1700 N/mm ²		30 – 40	30 – 40	30 – 40
N1	Alu-Knetlegierungen Wrought aluminum alloys	AlMg1	3.3315		Si < 9%	120 – 240	120 – 240	120 – 240
N2	Alu-Gusslegierungen Aluminum cast alloys	G-Alsi12	3.2581		Si > 9%	120 – 240	120 – 240	120 – 240
H1	Gehärtete Stähle Hardened steels				45 – 55 HRC	40 – 60	60 – 80	60 – 80

Schnittdaten dienen als Richtwerte und müssen dem Bearbeitungsumfeld angepasst werden.
Cutting data are reference values and need to be adjusted according to the application area.

Vorschubtablette fz (mm/Zahn) abhängig von D1 und Schnittbreite ae / Feed per tooth (mm/tooth) in relation with D1 and cutting width ae								
ae	ø 10	ø 12	ø 14	ø 16	ø 18	ø 20	ø 25	ø 32
bis/to 50% ø	0,060	0,072	0,084	0,096	0,108	0,120	0,15	0,2
100% ø	0,050	0,060	0,060	0,070	0,080	0,090	0,125	0,16

F1005NN – HAIMER MILL Power Series FASE/CHAMFER

Technische Daten und Produkteigenschaften/Technical data and Product characteristics



Wahlweise / Optional:

- Glattschaft DIN 6535-HA / Straight shank DIN 6535-HA
- Safe-Lock Schaft (S-λ) / Safe-Lock shank (S-λ)
- Weldonschaft ähnlich DIN 6535-HB / Weldon shank similar DIN 6535-HB



* = H

* = L

* = B

Eigenschaften Characteristics	Anwendung Application	Kühlung Coolant

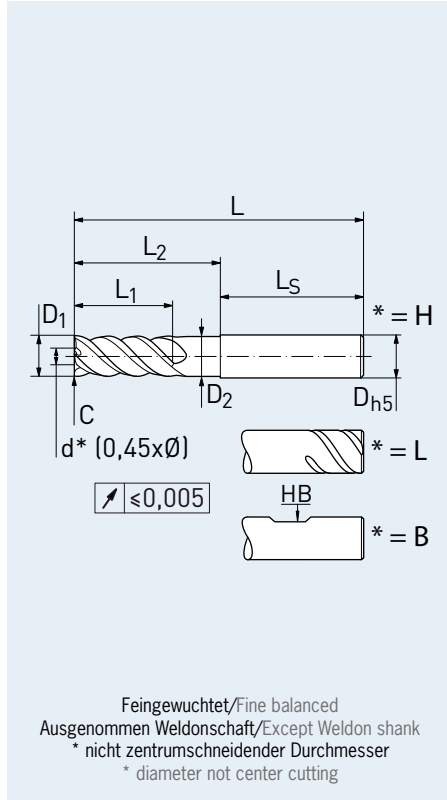

Material – Merkmale/Material – characteristics

Haupteinsatz
Main Material



auch geeignet für
also suitable for



- Halsabsatz für längere Eingriffstiefe
- Ungleiche Schneidenteilung
- Polierte Span- und Freiflächen

- Neck for higher cutting depth
- Unequal cutting edge
- Polished flute and relief



Artikel-Code Article-Code	Qualität Quality	D1 (h9) D1 (h9) [mm]	Schneidecke Cutting edge	Größe Size [mm]	L1 max. L1 max. [mm]	L L [mm]	L2 L2 [mm]	D2 D2 [mm]	D (h5) D (h5) [mm]	LS LS [mm]	Schaft Shank
F1005NN*1000C..	AA	10,00	C	0,30	22	73	30,5	9,5	10	40,5	HA/S-λ/HB
F1005NN*1200C..	AA	12,00	C	0,30	26	84	36,5	11,4	12	45,5	HA/S-λ/HB
F1005NN*1400C..	AA	14,00	C	0,40	26	84	36,5	13,3	14	45,5	HA/S-λ/HB
F1005NN*1600C..	AA	16,00	C	0,50	32	93	42,5	15,2	16	48,5	HA/S-λ/HB
F1005NN*1800C..	AA	18,00	C	0,50	32	93	42,5	17,1	18	48,5	HA/S-λ/HB
F1005NN*2000C..	AA	20,00	C	0,60	38	105	52	19	20	50,5	HA/S-λ/HB
F1005NN*2500C..	AA	25,00	C	0,70	45	122	61	24	25	57,0	HA/S-λ/HB
F1005NN*3200C..	AA	32,00	C	0,70	50	130	65	31	32	61,0	HA/S-λ/HB

* = L - Safe-Lock / H - Glattschaft / B - Weldonschaft. Bestellnummer = Artikel-Code + Qualität.

* = L - Safe-Lock / H - Straight shank / B - Weldon shank. Order No. = Article Code + Quality.

F1104NN – HAIMER MILL Power Series FASE SPANBRECHER/CHAMFER CHIP BREAKER

Schnittdaten/Cutting data

HAIMER Werkstoff Gruppen HAIMER Material groups	Beispiel Werkstoffe Example material	Werkstoffnr. Material no.	Werkstoff Information Material information		Schnittbreite/Cutting width			
			Zugfestigkeit Tensile strength	Inhalt/Härte Content/ Hardness				
					Schnittgeschwindigkeit Vc (m/min) Cutting speed Vc (m/min)			
P1	Allg. Bau-, Einsatzstähle General construction steels	S235JR (RST37-2), E295 (St 50-2), C45	1.0038, 1.0050, 1.0503	≤ 800 N/mm ²	bis 25 HRC up to 25 HRC	170 – 200	210 – 240	250 – 270
P2	Werkzeug/ Vergütungsstähle Heat treated steels	X38CrMoV5-3, X153CrMoV12, X100CrMoV5, 42CrMo4	1.2367, 1.2379, 1.2363, 1.7225	> 800 N/mm ²	bis 45 HRC up to 45 HRC	90 – 110	110 – 130	130 – 150
M1	Rostfreie Stähle Stainless steels	X8CrNiS18-9, X5CrNi18-10, X46Cr13	1.4305, 1.4301, 1.4034	≤ 650 N/mm ²		–	–	55 – 65
K1	Gusseisen Cast iron	EN-GJL200 (GG20), EN-GJLZ (GG40), EN-GJS-400-15 (GGG40)	0.6020, 0.6040, 0.7040	≤ 450 N/mm ²		110 – 130	130 – 150	200 – 220
K2	Gusseisen Cast iron	EN-GJS-600-3 (GGG60), EN-GJS-700-2 (GGG70)	0.7060, 0.7070	> 450 N/mm ²		90 – 110	110 – 130	160 – 180
S1	Titan & Titanlegierungen Titanium & titanium alloys	TiAl6V4	3.7165			60 – 80	60 – 80	60 – 80
N1	Alu-Knetlegierungen Wrought aluminum alloys	AlMg1	3.3315		Si < 9%	120 – 240	120 – 240	120 – 240
N2	Alu-Gusslegierungen Aluminum cast alloys	G-Alsi12	3.2581		Si > 9%	120 – 240	120 – 240	120 – 240
H1	Gehärtete Stähle Hardened steels				45 – 55 HRC	40 – 60	60 – 80	60 – 80

Schnittdaten dienen als Richtwerte und müssen dem Bearbeitungsumfeld angepasst werden.
Cutting data are reference values and need to be adjusted according to the application area.

Vorschubtable f _z (mm/Zahn) abhängig von D1 und Schnittbreite ae / Feed per tooth (mm/tooth) in relation with D1 and cutting width ae								
ae	ø 6	ø 8	ø 10	ø 12	ø 14	ø 16	ø 18	ø 20
bis/to 50% ø	0,036	0,048	0,060	0,072	0,084	0,096	0,108	0,120
100% ø	0,030	0,040	0,050	0,060	0,070	0,080	0,090	0,100
	0,006	0,008	0,010	0,012	0,014	0,016	0,018	0,020

F1104NN – HAIMER MILL Power Series FASE SPANBRECHER/CHAMFER CHIP BREAKER

Technische Daten und Produkteigenschaften/Technical data and Product characteristics

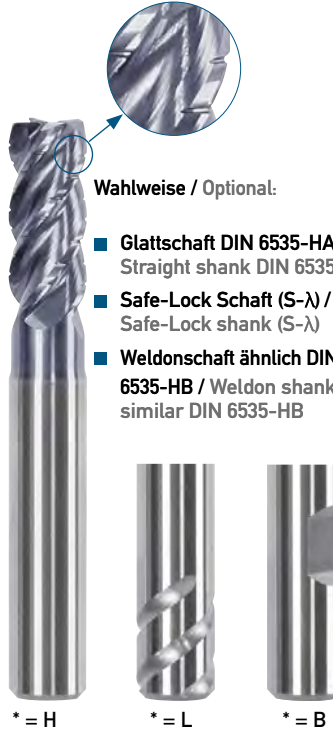

Wahlweise / Optional:

- Glattschaft DIN 6535-HA / Straight shank DIN 6535-HA
- Safe-Lock Schaft (S-λ) / Safe-Lock shank (S-λ)
- Weldonschaft ähnlich DIN 6535-HB / Weldon shank similar DIN 6535-HB

* = H * = L * = B

Eigenschaften
Characteristics

- DIN 6527 L
- 45°
- Z=4
- 41° / 43°

Anwendung
Application

- Center cutting
- 3-5° chamfer
- ap, ae
- ap, ae

Kühlung
Coolant

- Air
- MMS

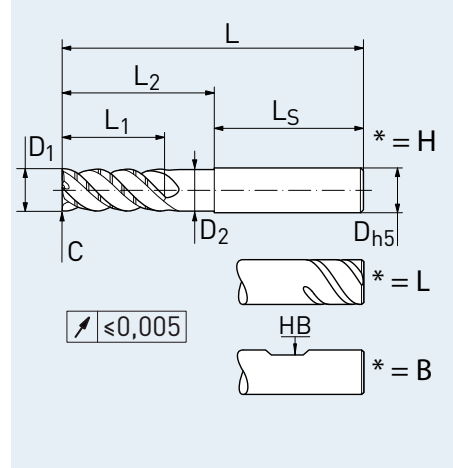

Feingewuchtet/Fine balanced
Ausgenommen Weldonschaft/Except Weldon shank

Material – Merkmale/Material – characteristics

Haupteinsatz
Main Material



auch geeignet für
also suitable for



- Halsabsatz für längere Eingriffstiefe
- Zentrumschneide
- Ungleiche Schneidenteilung
- Polierte Span- und Freiflächen

- Neck for higher cutting depth
- Center cutting
- Unequal cutting edge
- Polished flute and relief

Artikel-Code Article-Code	Qualität Quality	D1 (h9) D1 (h9) [mm]	Schneidecke Cutting edge	Größe Size [mm]	L1 max. L1 max. [mm]	L L [mm]	L2 L2 [mm]	D2 D2 [mm]	D (h5) D (h5) [mm]	LS LS [mm]	Schaft Shank
F1104NN*0600C..	AA	6,00	C	0,20	13	58	20	5,7	6	36,5	HA/S-λ/HB
F1104NN*0800C..	AA	8,00	C	0,20	19	64	26	7,6	8	36,5	HA/S-λ/HB
F1104NN*1000C..	AA	10,00	C	0,30	22	73	30,5	9,5	10	40,5	HA/S-λ/HB
F1104NN*1200C..	AA	12,00	C	0,30	26	84	36,5	11,4	12	45,5	HA/S-λ/HB
F1104NN*1400C..	AA	14,00	C	0,40	26	84	36,5	13,3	14	45,5	HA/S-λ/HB
F1104NN*1600C..	AA	16,00	C	0,50	32	93	42,5	15,2	16	48,5	HA/S-λ/HB
F1104NN*1800C..	AA	18,00	C	0,50	32	93	42,5	17,1	18	48,5	HA/S-λ/HB
F1104NN*2000C..	AA	20,00	C	0,60	38	105	52	19	20	50,5	HA/S-λ/HB

* = L - Safe-Lock / H - Glattschaft / B - Weldonschaft. Bestellnummer = Artikel-Code + Qualität.
* = L - Safe-Lock / H - Straight shank / B - Weldon shank. Order No. = Article Code + Quality.

F1105LL – HAIMER MILL Power Series

FASE SPANBRECHER/CHAMFER CHIP BREAKER

Schnittdaten/Cutting data

HAIMER Werkstoff Gruppen HAIMER Material groups		Beispiel Werkstoffe Example material		Werkstoff Information Material information		Schnittbreite Cutting width
		DIN DIN	Werkstoffnr. Material no.	Zugfestigkeit Tensile strength	Inhalt/Härte Content/ Hardness	Schnittgeschwindigkeit Vc (m/min) Cutting speed Vc (m/min)
P1	Allg. Bau-, Einsatzstähle General construction steels	S235JR (RST37-2), E295 (St 50-2), C45	1.0038, 1.0050, 1.0503	≤ 800 N/mm ²	bis 25 HRC up to 25 HRC	250 – 270
P2	Werkzeug/ Vergütungsstähle Heat treated steels	X38CrMoV5-3, X153CrMoV12, X100CrMoV5, 42CrMo4	1.2367, 1.2379, 1.2363, 1.7225	> 800 N/mm ²	bis 45 HRC up to 45 HRC	130 – 150
M1	Rostfreie Stähle Stainless steels	X8CrNiS18-9, X5CrNi18-10, X46Cr13	1.4305, 1.4301, 1.4034	≤ 650 N/mm ²		55 – 65
K1	Gusseisen Cast iron	EN-GJL200 (GG20), EN-GJLZ (GG40), EN- GJS-400-15 (GGG40)	0.6020, 0.6040, 0.7040	≤ 450 N/mm ²		200 – 220
K2	Gusseisen Cast iron	EN-GJS-600-3 (GGG60), EN-GJS-700-2 (GGG70)	0.7060, 0.7070	> 450 N/mm ²		160 – 180
S1	Titan & Titanlegierungen Titanium & titanium alloys	TiAl6V4	3.7165			60 – 80
N1	Alu-Knetlegierungen Wrought aluminum alloys	AlMg1	3.3315		Si < 9%	120 – 240
N2	Alu-Gusslegierungen Aluminum cast alloys	G-Alsi12	3.2581		Si > 9%	120 – 240
H1	Gehärtete Stähle Hardened steels				45 – 55 HRC	60 – 80

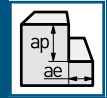

ae = 5% D1
ap = L1 max.

Schnittdaten dienen als Richtwerte und müssen dem Bearbeitungsumfeld angepasst werden.
 Cutting data are reference values and need to be adjusted according to the application area.

Vorschubtable f_z (mm/Zahn) abhängig von D1 und Schnittbreite ae / Feed per tooth (mm/tooth) in relation with D1 and cutting width ae

ae	ø 6	ø 8	ø 10	ø 12	ø 14	ø 16	ø 18	ø 20
bis/to 5% ø	0,051	0,068	0,085	0,102	0,119	0,136	0,153	0,170

F1105LL – HAIMER MILL Power Series FASE SPANBRECHER/CHAMFER CHIP BREAKER

Technische Daten und Produkteigenschaften/Technical data and Product characteristics

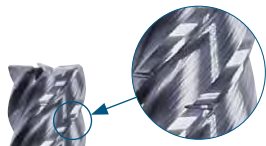

Wahlweise / Optional:

- Glattschaft DIN 6535-HA / Straight shank DIN 6535-HA
- Safe-Lock Schaft (S-λ) / Safe-Lock shank (S-λ)
- Weldonschaft ähnlich DIN 6535-HB / Weldon shank similar DIN 6535-HB

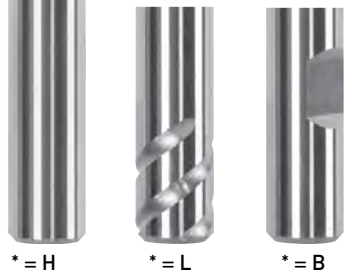

Eigenschaften Characteristics



Anwendung Application



Kühlung Coolant

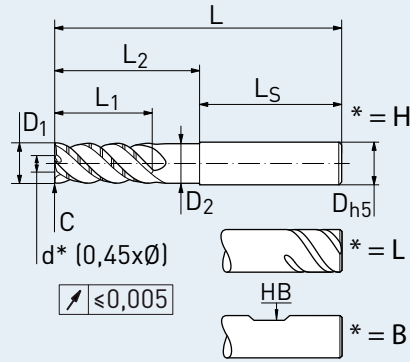

Feingewuchtet/Fine balanced
Ausgenommen Weldonschaft/Except Weldon shank
* nicht zentrumschneidender Durchmesser
* diameter not center cutting

Material – Merkmale/Material – characteristics

Haupteinsatz
Main Material



auch geeignet für
also suitable for



- Halsabsatz für längere Eingriffstiefe
- Ungleiche Schneidenteilung
- Schneidenlänge: lang
- Polierte Span- und Freiflächen

- Neck for higher cutting depth
- Unequal cutting edge
- Length of cutting edge: long
- Polished flute and relief

Artikel-Code Article-Code	Qualität Quality	D1 (h9) D1 (h9) [mm]	Schneidecke Cutting edge	Größe Size [mm]	L1 max. L1 max. [mm]	L L [mm]	L2 L2 [mm]	D2 D2 [mm]	D (h5) D (h5) [mm]	LS LS [mm]	Schaft Shank
F1105LL*0600C..	AA	6,00	C	0,20	18	62	24	5,7	6	36,5	HA/S-λ/HB
F1105LL*0800C..	AA	8,00	C	0,20	24	70	32	7,6	8	36,5	HA/S-λ/HB
F1105LL*1000C..	AA	10,00	C	0,30	30	82	40	9,5	10	40,5	HA/S-λ/HB
F1105LL*1200C..	AA	12,00	C	0,30	36	95	48	11,4	12	45,5	HA/S-λ/HB
F1105LL*1400C..	AA	14,00	C	0,40	42	105	56	13,3	14	46,5	HA/S-λ/HB
F1105LL*1600C..	AA	16,00	C	0,50	48	115	64	15,2	16	48,5	HA/S-λ/HB
F1105LL*1800C..	AA	18,00	C	0,50	54	123	72	17,1	18	48	HA/S-λ/HB
F1105LL*2000C..	AA	20,00	C	0,60	60	133	80	19,0	20	50,5	HA/S-λ/HB

* = L - Safe-Lock / H - Glattschaft / B - Weldonschaft. Bestellnummer = Artikel-Code + Qualität.
* = L - Safe-Lock / H - Straight shank / B - Weldon shank. Order No. = Article Code + Quality.

F1304NN – HAIMER MILL Power Series FASE SCHRUPPVERZÄHNUNG/CHAMFER ROUGHING

Schnittdaten/Cutting data

HAIMER Werkstoff Gruppen HAIMER Material groups	Beispiel Werkstoffe Example material	Werkstoffnr. Material no.	Werkstoff Information Material information		Schnittbreite/Cutting width			
			Zugfestigkeit Tensile strength	Inhalt/Härte Content/ Hardness				
					Schnittgeschwindigkeit Vc (m/min) Cutting speed Vc (m/min)			
P1	Allg. Bau-, Einsatzstähle General construction steels	S235JR (RST37-2), E295 (St 50-2), C45	1.0038, 1.0050, 1.0503	≤ 800 N/mm ²	bis 25 HRC up to 25 HRC	170 – 200	210 – 240	250 – 270
P2	Werkzeug/Vergütungsstähle Heat treated steels	X38CrMoV5-3, X153CrMoV12, X100CrMoV5, 42CrMo4	1.2367, 1.2379, 1.2363, 1.7225	> 800 N/mm ²	bis 45 HRC up to 45 HRC	90 – 110	110 – 130	130 – 150
M1	Rostfreie Stähle Stainless steels	X8CrNiS18-9, X5CrNi18-10, X46Cr13	1.4305, 1.4301, 1.4034	≤ 650 N/mm ²		–	–	55 – 65
K1	Gusseisen Cast iron	EN-GJL200 (GG20), EN-GJLZ (GG40), EN-GJS-400-15 (GGG40)	0.6020, 0.6040, 0.7040	≤ 450 N/mm ²		110 – 130	130 – 150	200 – 220
K2	Gusseisen Cast iron	EN-GJS-600-3 (GGG60), EN-GJS-700-2 (GGG70)	0.7060, 0.7070	> 450 N/mm ²		90 – 110	110 – 130	160 – 180
S1	Titan & Titanlegierungen Titanium & titanium alloys	TiAl6V4	3.7165			60 – 80	60 – 80	60 – 80
N1	Alu-Knetlegierungen Wrought aluminum alloys	AlMg1	3.3315		Si < 9%	120 – 240	120 – 240	120 – 240
N2	Alu-Gusslegierungen Aluminum cast alloys	G-Alsi12	3.2581		Si > 9%	120 – 240	120 – 240	120 – 240

Schnittdaten dienen als Richtwerte und müssen dem Bearbeitungsumfeld angepasst werden.
Cutting data are reference values and need to be adjusted according to the application area.

Vorschubtable f _z (mm/Zahn) abhängig von D1 und Schnittbreite ae /Feed per tooth (mm/tooth) in relation with D1 and cutting width ae								
ae	ø 6	ø 8	ø 10	ø 12	ø 14	ø 16	ø 18	ø 20
bis/to 50% ø	0,036	0,048	0,060	0,072	0,084	0,096	0,108	0,120
100% ø	0,030	0,040	0,050	0,060	0,070	0,080	0,090	0,100

F1304NN – HAIMER MILL Power Series FASE SCHRUPPVERZÄHNUNG/CHAMFER ROUGHING

Technische Daten und Produkteigenschaften/Technical data and Product characteristics



Wahlweise / Optional:

- Glattschaft DIN 6535-HA / Straight shank DIN 6535-HA
- Safe-Lock Schaft (S-λ) / Safe-Lock shank (S-λ)
- Weldonschaft ähnlich DIN 6535-HB / Weldon shank similar DIN 6535-HB



* = H



* = L

Eigenschaften
Characteristics

Anwendung
Application

Kühlung
Coolant

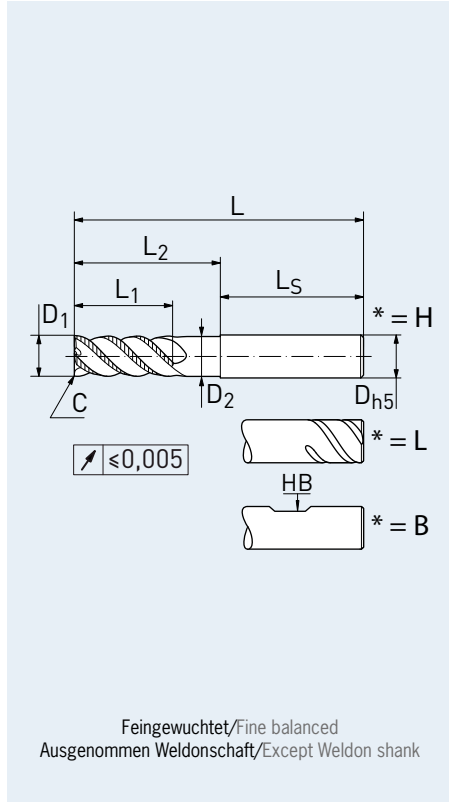

Material – Merkmale/Material – characteristics

Haupteinsatz
Main Material



auch geeignet für
also suitable for



- Halsabsatz für längere Eingriffstiefe
- Zentrumschneide
- Ungleiche Schneidenteilung
- Polierte Span- und Freiflächen

- Neck for higher cutting depth
- Center cutting
- Unequal cutting edge
- Polished flute and relief

Artikel-Code Article-Code	Qualität Quality	D1 (h9) D1 (h9) [mm]	Schneidecke Cutting edge	Größe Size [mm]	L1 max. L1 max. [mm]	L L [mm]	L2 L2 [mm]	D2 D2 [mm]	D (h5) D (h5) [mm]	LS LS [mm]	Schaft Shank
F1304NN*0600C..	AA	6,00	C	0,20	13	58	20	5,7	6	36,5	HA/S-λ/HB
F1304NN*0800C..	AA	8,00	C	0,20	19	64	26	7,6	8	36,5	HA/S-λ/HB
F1304NN*1000C..	AA	10,00	C	0,30	22	73	30,5	9,5	10	40,5	HA/S-λ/HB
F1304NN*1200C..	AA	12,00	C	0,30	26	84	36,5	11,4	12	45,5	HA/S-λ/HB
F1304NN*1400C..	AA	14,00	C	0,40	26	84	36,5	13,3	14	45,5	HA/S-λ/HB
F1304NN*1600C..	AA	16,00	C	0,50	32	93	42,5	15,2	16	48,5	HA/S-λ/HB
F1304NN*1800C..	AA	18,00	C	0,50	32	93	42,5	17,1	18	48,5	HA/S-λ/HB
F1304NN*2000C..	AA	20,00	C	0,60	38	105	52	19	20	50,5	HA/S-λ/HB

* = L - Safe-Lock / H - Glattschaft / B - Weldonschaft. Bestellnummer = Artikel-Code + Qualität.
* = L - Safe-Lock / H - Straight shank / B - Weldon shank. Order No. = Article Code + Quality.

F2004NN – HAIMER MILL SCHARFKANTIG/SHARP CUTTING EDGE

Schnittdaten/Cutting data





HAIMER Werkstoff Gruppen HAIMER Material groups	Beispiel Werkstoffe Example material	Werkstoffnr. Material no.	Werkstoff Information Material information		Schnittbreite/Cutting width	Schnittgeschwindigkeit Vc (m/min) Cutting speed Vc (m/min)			
			Zugfestigkeit Tensile strength	Inhalt/Härte Content/ Hardness		Rampe Ramping	Schnittgeschwindigkeit Vc (m/min) Cutting speed Vc (m/min)		
P1	Allg. Bau-, Einsatzstähle General construction steels	S235JR (RST37-2), E295 (St 50-2), C45	1.0038, 1.0050, 1.0503	≤ 800 N/mm ²	bis 25 HRC up to 25 HRC	45°	255 – 275	320 – 340	400 – 420
P2	Werkzeug/ Vergütungsstähle Heat treated steels	X38CrMoV5-3, X153CrMoV12, X100CrMoV5, 42CrMo4	1.2367, 1.2379, 1.2363, 1.7225	> 800 N/mm ²	bis 45 HRC up to 45 HRC	30°	190 – 210	220 – 240	290 – 310
M1	Rostfreie Stähle Stainless steels	X8CrNiS18-9, X5CrNi18-10, X46Cr13	1.4305, 1.4301, 1.4034	≤ 650 N/mm ²		10°	95 – 110	115 – 135	150 – 170
M2	Rostfreie Stähle Stainless steels	X6CrNiMoTi17-12-2, X2CrNiMo17-12-2, X4CrNiMo16-5-1	1.4571, 1.4404, 1.4418	> 650 N/mm ²		5°	75 – 90	95 – 105	110 – 130
K1	Gusseisen Cast iron	EN-GJL200 (GG20), EN- GJLZ (GG40), EN- GJS-400-15 (GGG40)	0.6020, 0.6040, 0.7040	≤ 450 N/mm ²		45°	160 – 180	180 – 200	210 – 230
K2	Gusseisen Cast iron	EN-GJS-600-3 (GGG60) EN-GJS-700-2 (GGG70)	0.7060, 0.7070	> 450 N/mm ²		20°	130 – 150	150 – 170	180 – 200
S1	Titan & Titanlegierungen Titanium & titanium alloys	TiAl6V4	3.7165			10°	50 – 60	60 – 80	80 – 90
S2	Warmfeste Legierungen High Temp alloys	Inconel; NIMONIC		800 – 1700 N/ mm ²		5°	30 – 40	30 – 40	30 – 40
N1	Alu-Knetlegierungen Wrought aluminum alloys	AlMg1	3.3315		Si < 9%	30°	470 – 490	600 – 630	780 – 820
N2	Alu-Gusslegierungen Aluminum cast alloys	G-AlSi12	3.2581		Si > 9%	30°	340 – 360	420 – 440	540 – 580
H1	Gehärtete Stähle Hardened steels				45 – 55 HRC	10°	40 – 60	60 – 80	60 – 80

Schnittdaten dienen als Richtwerte und müssen dem Bearbeitungsumfeld angepasst werden.

Beim Bohren wird Entspannen je nach Werkstoff, bei 0,5 – 1 x D empfohlen.

Cutting data are reference values and need to be adjusted according to the application area.

Chip removal recommended for drilling depth 0,5 – 1 x D.

Vorschubtable f _z (mm/Zahn) abhängig von D1 und Schnittbreite ae / Feed per tooth (mm/tooth) in relation with D1 and cutting width ae													
ae	ø 2	ø 3	ø 4	ø 5	ø 6	ø 8	ø 10	ø 12	ø 14	ø 16	ø 18	ø 20	
bis/to 50% ø	0,013	0,020	0,026	0,033	0,039	0,052	0,065	0,078	0,091	0,104	0,117	0,13	
100% ø	0,011	0,017	0,022*	0,028*	0,033*	0,044*	0,055*	0,066*	0,077*	0,088*	0,099*	0,11*	
	P	0,009	0,014	0,018	0,023	0,027	0,036	0,045	0,054	0,063	0,072	0,081	0,09
	M	0,005	0,008	0,01	0,013	0,015	0,020	0,025	0,030	0,035	0,040	0,045	0,05
	K	0,008	0,012	0,016	0,020	0,024	0,032	0,040	0,048	0,056	0,064	0,072	0,08
	S	0,004	0,006	0,008	0,010	0,012	0,016	0,020	0,024	0,028	0,032	0,036	0,04
	N	0,009	0,014	0,018	0,023	0,027	0,036	0,045	0,054	0,063	0,072	0,081	0,09

*Beim Nutfräsen (100% ø) im Material M1, M2, S1 und S2 ist der angegebene f_z um 30% zu reduzieren.

*For Slotting (100% ø) in material M1, M2, S1 and S2 reduce f_z by 30%.

F2004NN – HAIMER MILL SCHARFKANTIG/SHARP CUTTING EDGE

Technische Daten und Produkteigenschaften/Technical data and Product characteristics



Wahlweise / Optional:

- Glattschaft DIN 6535-HA / Straight shank DIN 6535-HA
- Safe-Lock Schaft (S-λ) / Safe-Lock shank (S-λ)
- Weldonschaft ähnlich DIN 6535-HB / Weldon shank similar DIN 6535-HB

* = H

* = L

* = B

Eigenschaften Characteristics

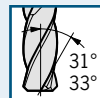

Anwendung Application

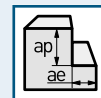
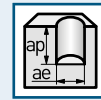
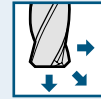

Kühlung Coolant

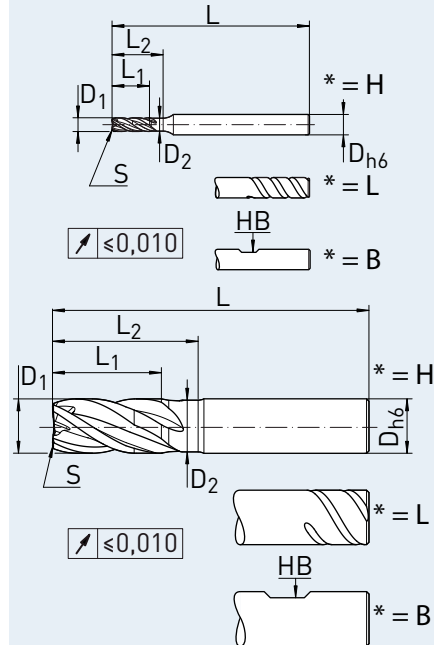
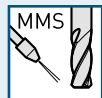

Material – Merkmale/Material – characteristics

Haupteinsatz
Main Material



auch geeignet für
also suitable for

- Halsabsatz für längere Eingriffstiefe
- Zentrumschneide
- Ungleiche Schneidenteilung

- Neck for higher cutting depth
- Center cutting
- Unequal cutting edge

Artikel-Code Article-Code	Qualität Quality	D1 (f9) D1 (f9) [mm]	Schneidecke Cutting edge	L1 max. L1 max. [mm]	L L [mm]	L2 L2 [mm]	D2 D2 [mm]	D (h6) D (h6) [mm]	Schaft Shank h6
F2004NN*0200S..	DA	2,00	S	7	58	9	1,9	6	HA/S-λ/HB
F2004NN*0300S..	DA	3,00	S	8	58	10	2,9	6	HA/S-λ/HB
F2004NN*0400S..	DA	4,00	S	11	58	15	3,8	6	HA/S-λ/HB
F2004NN*0500S..	DA	5,00	S	13	58	18	4,8	6	HA/S-λ/HB
F2004NN*0600S..	DA	6,00	S	13	58	20	5,7	6	HA/S-λ/HB
F2004NN*0800S..	DA	8,00	S	19	64	26	7,6	8	HA/S-λ/HB
F2004NN*1000S..	DA	10,00	S	22	73	30,5	9,5	10	HA/S-λ/HB
F2004NN*1200S..	DA	12,00	S	26	84	36,5	11,4	12	HA/S-λ/HB
F2004NN*1400S..	DA	14,00	S	26	84	36,5	13,3	14	HA/S-λ/HB
F2004NN*1600S..	DA	16,00	S	32	93	42,5	15,2	16	HA/S-λ/HB
F2004NN*1800S..	DA	18,00	S	32	93	42,5	17,1	18	HA/S-λ/HB
F2004NN*2000S..	DA	20,00	S	38	105	52	19	20	HA/S-λ/HB

* = L - Safe-Lock / H - Glattschaft / B - Weldonschaft. Bestellnummer = Artikel-Code + Qualität.

* = L - Safe-Lock / H - Straight shank / B - Weldon shank. Order No. = Article Code + Quality.

F2004NN – HAIMER MILL FASE UNTERMASS/CHAMFER UNDERSIZE

Technische Daten und Produkteigenschaften/Technical data and Product characteristics



Wahlweise / Optional:

- Glattschaft DIN 6535-HA / Straight shank DIN 6535-HA
- Safe-Lock Schaft (S-λ) / Safe-Lock shank (S-λ)
- Weldonschaft ähnlich DIN 6535-HB / Weldon shank similar DIN 6535-HB

* = H * = L * = B

Eigenschaften Characteristics	Anwendung Application	Kühlung Coolant

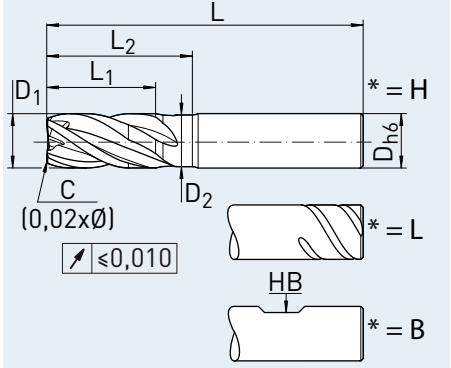

Material – Merkmale/Material – characteristics

Haupteinsatz
Main Material



auch geeignet für
also suitable for

- Halsabsatz für längere Eingriffstiefe
- Zentrumschneide
- Ungleiche Schneidenteilung

- Neck for higher cutting depth
- Center cutting
- Unequal cutting edge

Für höchste Zerspanleistung und Standzeit empfehlen wir unsere Power-Aufnahmenserie in Verbindung mit Cool Jet oder Cool Flash.
Cooling with Cool Jet or Cool Flash and using Power Chucks is recommended for higher tool life and high removal rate.

Artikel-Code Article-Code	Qualität Quality	D1 (f9) D1 (f9) [mm]	Schneidecke Cutting edge	Größe Size [mm]	L1 max. L1 max. [mm]	L L [mm]	L2 L2 [mm]	D2 D2 [mm]	D (h6) D (h6) [mm]	Schaft Shank h6
F2004NN*0570C..	DA	5,70	C	0,12	13	58	20	5,7	6	HA/S-λ/HB
F2004NN*0770C..	DA	7,70	C	0,16	19	64	26	7,6	8	HA/S-λ/HB
F2004NN*0970C..	DA	9,70	C	0,20	22	73	30,5	9,5	10	HA/S-λ/HB
F2004NN*1170C..	DA	11,70	C	0,24	26	84	36,5	11,4	12	HA/S-λ/HB
F2004NN*1370C..	DA	13,70	C	0,28	26	84	36,5	13,3	14	HA/S-λ/HB
F2004NN*1560C..	DA	15,60	C	0,32	32	93	42,5	15,2	16	HA/S-λ/HB
F2004NN*1950C..	DA	19,50	C	0,40	38	105	52	19	20	HA/S-λ/HB

* = L - Safe-Lock / H - Glattschaft / B - Weldonschaft. Bestellnummer = Artikel-Code + Qualität.

* = L - Safe-Lock / H - Straight shank / B - Weldon shank. Order No. = Article Code + Quality.

F2004NN – HAIMER MILL FASE/CHAMFER

Technische Daten und Produkteigenschaften/Technical data and Product characteristics

Wahlweise / Optional:

- Glattschaft DIN 6535-HA / Straight shank DIN 6535-HA
- Safe-Lock Schaft (S-λ) / Safe-Lock shank (S-λ)
- Weldonschaft ähnlich DIN 6535-HB / Weldon shank similar DIN 6535-HB

* = H * = L * = B

Eigenschaften
Characteristics

- DIN 6527 L
- 45°
- Z=4
- 31° / 33°

Anwendung
Application

- 45° chamfering
- ap, ae
- ap, ae
- ap, ae

Kühlung
Coolant

- Air
- MMS

Material – Merkmale/Material – characteristics

Haupteinsatz
Main Material



auch geeignet für
also suitable for

- Halsabsatz für längere Eingriffstiefe
- Zentrumschneide
- Ungleiche Schneidenteilung

- Neck for higher cutting depth
- Center cutting
- Unequal cutting edge

Artikel-Code Article-Code	Qualität Quality	D1 (f9) D1 (f9) [mm]	Schneidecke Cutting edge	Größe Size [mm]	L1 max. L1 max. [mm]	L L [mm]	L2 L2 [mm]	D2 D2 [mm]	D (h6) D (h6) [mm]	Schaft Shank h6
F2004NN*0200C..	DA	2,00	C	0,04	7	58	9	1,9	6	HA/S-λ/HB
F2004NN*0300C..	DA	3,00	C	0,06	8	58	10	2,9	6	HA/S-λ/HB
F2004NN*0400C..	DA	4,00	C	0,08	11	58	15	3,8	6	HA/S-λ/HB
F2004NN*0500C..	DA	5,00	C	0,10	13	58	18	4,8	6	HA/S-λ/HB
F2004NN*0600C..	DA	6,00	C	0,12	13	58	20	5,7	6	HA/S-λ/HB
F2004NN*0800C..	DA	8,00	C	0,16	19	64	26	7,6	8	HA/S-λ/HB
F2004NN*1000C..	DA	10,00	C	0,20	22	73	30,5	9,5	10	HA/S-λ/HB
F2004NN*1200C..	DA	12,00	C	0,24	26	84	36,5	11,4	12	HA/S-λ/HB
F2004NN*1400C..	DA	14,00	C	0,28	26	84	36,5	13,3	14	HA/S-λ/HB
F2004NN*1600C..	DA	16,00	C	0,32	32	93	42,5	15,2	16	HA/S-λ/HB
F2004NN*1800C..	DA	18,00	C	0,36	32	93	42,5	17,1	18	HA/S-λ/HB
F2004NN*2000C..	DA	20,00	C	0,40	38	105	52	19	20	HA/S-λ/HB

* = L - Safe-Lock / H - Glattschaft / B - Weldonschaft. Bestellnummer = Artikel-Code + Qualität.

* = L - Safe-Lock / H - Straight shank / B - Weldon shank. Order No. = Article Code + Quality.

F2004NN – HAIMER MILL ECKENRADIUS/CORNER RADIUS





Technische Daten und Produkteigenschaften/Technical data and Product characteristics





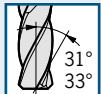

Wahlweise / Optional:

- Glattschaft DIN 6535-HA / Straight shank DIN 6535-HA
- Safe-Lock Schaft (S-λ) / Safe-Lock shank (S-λ)
- Weldonschaft ähnlich DIN 6535-HB / Weldon shank similar DIN 6535-HB



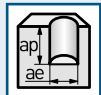
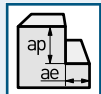

Eigenschaften
Characteristics





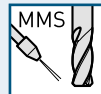

Anwendung
Application

Kühlung
Coolant

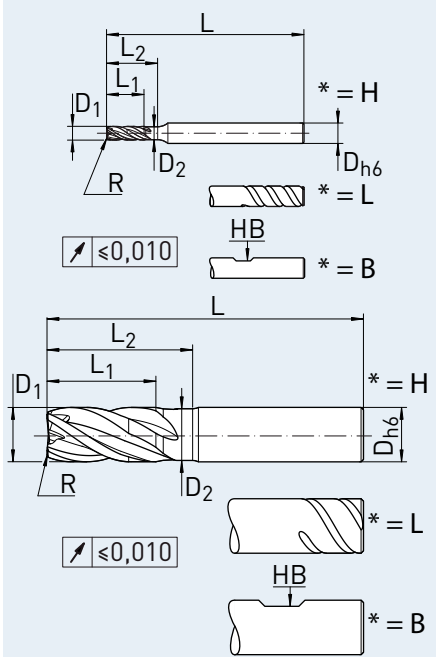

Material – Merkmale/Material – characteristics

Haupteinsatz
Main Material



auch geeignet für
also suitable for

- Halsabsatz für längere Eingriffstiefe
- Zentrumschneide
- Ungleiche Schneidenteilung

- Neck for higher cutting depth
- Center cutting
- Unequal cutting edge

Artikel-Code Article-Code	Qualität Quality	D1 (f9) D1 (f9) [mm]	Schneidecke Cutting edge	Größe Size [mm]	L1 max. L1 max. [mm]	L L [mm]	L2 L2 [mm]	D2 D2 [mm]	D (h6) D (h6) [mm]	Schaft Shank
F2004NN*0200R0.20..	DA	2,00	R	0,20	7	58	9	1,9	6	HA/S-λ/HB
F2004NN*0300R0.30..	DA	3,00	R	0,30	8	58	10	2,9	6	HA/S-λ/HB
F2004NN*0400R0.30..	DA	4,00	R	0,30	11	58	15	3,8	6	HA/S-λ/HB
F2004NN*0400R0.40..	DA	4,00	R	0,40	11	58	15	3,8	6	HA/S-λ/HB
F2004NN*0400R0.50..	DA	4,00	R	0,50	11	58	15	3,8	6	HA/S-λ/HB
F2004NN*0500R0.30..	DA	5,00	R	0,30	13	58	18	4,8	6	HA/S-λ/HB
F2004NN*0500R0.50..	DA	5,00	R	0,50	13	58	18	4,8	6	HA/S-λ/HB
F2004NN*0500R1.00..	DA	5,00	R	1,00	13	58	18	4,8	6	HA/S-λ/HB
F2004NN*0600R0.30..	DA	6,00	R	0,30	13	58	20	5,7	6	HA/S-λ/HB
F2004NN*0600R0.50..	DA	6,00	R	0,50	13	58	20	5,7	6	HA/S-λ/HB
F2004NN*0600R0.80..	DA	6,00	R	0,80	13	58	20	5,7	6	HA/S-λ/HB
F2004NN*0600R1.00..	DA	6,00	R	1,00	13	58	20	5,7	6	HA/S-λ/HB

⇒ Weitere Artikel siehe nächste Seite/Turn page for more articles

F2004NN – HAIMER MILL ECKENRADIUS/CORNER RADIUS

Artikel-Code Article-Code	Qualität Quality	D1 (f9) D1 (f9) [mm]	Schneidecke Cutting edge	Größe Size [mm]	L1 max. L1 max. [mm]	L L [mm]	L2 L2 [mm]	D2 D2 [mm]	D (h6) D (h6) [mm]	Schaft Shank
F2004NN*0600R1.50..	DA	6,00	R	1,50	13	58	20	5,7	6	HA/S-λ/HB
F2004NN*0600R2.00..	DA	6,00	R	2,00	13	58	20	5,7	6	HA/S-λ/HB
F2004NN*0800R0.30..	DA	8,00	R	0,30	19	64	26	7,6	8	HA/S-λ/HB
F2004NN*0800R0.50..	DA	8,00	R	0,50	19	64	26	7,6	8	HA/S-λ/HB
F2004NN*0800R0.80..	DA	8,00	R	0,80	19	64	26	7,6	8	HA/S-λ/HB
F2004NN*0800R1.00..	DA	8,00	R	1,00	19	64	26	7,6	8	HA/S-λ/HB
F2004NN*0800R1.50..	DA	8,00	R	1,50	19	64	26	7,6	8	HA/S-λ/HB
F2004NN*0800R2.00..	DA	8,00	R	2,00	19	64	26	7,6	8	HA/S-λ/HB
F2004NN*1000R0.30..	DA	10,00	R	0,30	22	73	30,5	9,5	10	HA/S-λ/HB
F2004NN*1000R0.50..	DA	10,00	R	0,50	22	73	30,5	9,5	10	HA/S-λ/HB
F2004NN*1000R0.80..	DA	10,00	R	0,80	22	73	30,5	9,5	10	HA/S-λ/HB
F2004NN*1000R1.00..	DA	10,00	R	1,00	22	73	30,5	9,5	10	HA/S-λ/HB
F2004NN*1000R1.50..	DA	10,00	R	1,50	22	73	30,5	9,5	10	HA/S-λ/HB
F2004NN*1000R2.00..	DA	10,00	R	2,00	22	73	30,5	9,5	10	HA/S-λ/HB
F2004NN*1000R2.50..	DA	10,00	R	2,50	22	73	30,5	9,5	10	HA/S-λ/HB
F2004NN*1200R0.30..	DA	12,00	R	0,30	26	84	36,5	11,4	12	HA/S-λ/HB
F2004NN*1200R0.50..	DA	12,00	R	0,50	26	84	36,5	11,4	12	HA/S-λ/HB
F2004NN*1200R0.80..	DA	12,00	R	0,80	26	84	36,5	11,4	12	HA/S-λ/HB
F2004NN*1200R1.00..	DA	12,00	R	1,00	26	84	36,5	11,4	12	HA/S-λ/HB
F2004NN*1200R1.50..	DA	12,00	R	1,50	26	84	36,5	11,4	12	HA/S-λ/HB
F2004NN*1200R2.00..	DA	12,00	R	2,00	26	84	36,5	11,4	12	HA/S-λ/HB
F2004NN*1200R2.50..	DA	12,00	R	2,50	26	84	36,5	11,4	12	HA/S-λ/HB
F2004NN*1200R3.00..	DA	12,00	R	3,00	26	84	36,5	11,4	12	HA/S-λ/HB
F2004NN*1200R4.00..	DA	12,00	R	4,00	26	84	36,5	11,4	12	HA/S-λ/HB
F2004NN*1400R0.50..	DA	14,00	R	0,50	26	84	36,5	13,3	14	HA/S-λ/HB
F2004NN*1400R1.00..	DA	14,00	R	1,00	26	84	36,5	13,3	14	HA/S-λ/HB
F2004NN*1400R2.00..	DA	14,00	R	2,00	26	84	36,5	13,3	14	HA/S-λ/HB
F2004NN*1600R0.30..	DA	16,00	R	0,30	32	93	42,5	15,2	16	HA/S-λ/HB
F2004NN*1600R0.50..	DA	16,00	R	0,50	32	93	42,5	15,2	16	HA/S-λ/HB
F2004NN*1600R0.80..	DA	16,00	R	0,80	32	93	42,5	15,2	16	HA/S-λ/HB
F2004NN*1600R1.00..	DA	16,00	R	1,00	32	93	42,5	15,2	16	HA/S-λ/HB
F2004NN*1600R1.50..	DA	16,00	R	1,50	32	93	42,5	15,2	16	HA/S-λ/HB
F2004NN*1600R2.00..	DA	16,00	R	2,00	32	93	42,5	15,2	16	HA/S-λ/HB
F2004NN*1600R3.00..	DA	16,00	R	3,00	32	93	42,5	15,2	16	HA/S-λ/HB
F2004NN*1600R4.00..	DA	16,00	R	4,00	32	93	42,5	15,2	16	HA/S-λ/HB
F2004NN*1800R0.50..	DA	18,00	R	0,50	32	93	42,5	17,1	18	HA/S-λ/HB
F2004NN*1800R1.00..	DA	18,00	R	1,00	32	93	42,5	17,1	18	HA/S-λ/HB
F2004NN*1800R2.00..	DA	18,00	R	2,00	32	93	42,5	17,1	18	HA/S-λ/HB

⇒ Weitere Artikel siehe nächste Seite/Turn page for more articles

* = L - Safe-Lock / H - Glattschaft / B - Weldonschaft. Bestellnummer = Artikel-Code + Qualität.
* = L - Safe-Lock / H - Straight shank / B- Weldon shank. Order No. = Article Code + Quality.

F2004NN – HAIMER MILL ECKENRADIUS/CORNER RADIUS

Technische Daten und Produkteigenschaften/Technical data and Product characteristics



Wahlweise / Optional:

- Glattschaft DIN 6535-HA / Straight shank DIN 6535-HA
- Safe-Lock Schaft (S-λ) / Safe-Lock shank (S-λ)
- Weldonschaft ähnlich DIN 6535-HB / Weldon shank similar DIN 6535-HB

* = H * = L * = B

Eigenschaften Characteristics	Anwendung Application	Kühlung Coolant

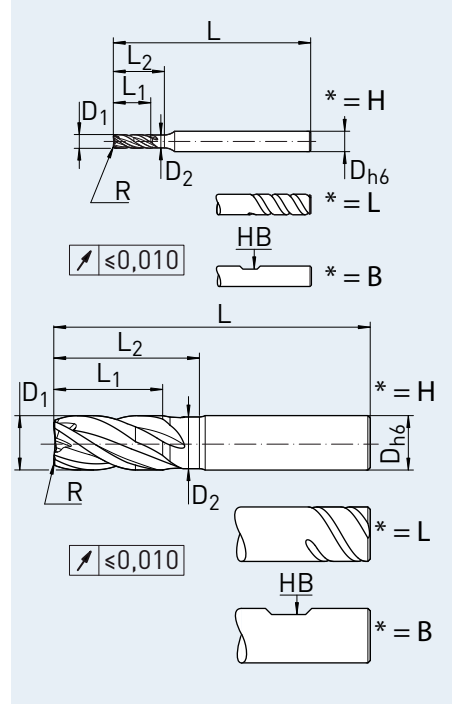

Material – Merkmale/Material – characteristics

Haupteinsatz
Main Material



auch geeignet für
also suitable for

- Halsabsatz für längere Eingriffstiefe
- Zentrumschneide
- Ungleiche Schneidenteilung

- Neck for higher cutting depth
- Center cutting
- Unequal cutting edge

Artikel-Code Article-Code	Qualität Quality	D1 (f9) D1 (f9) [mm]	Schneidecke Cutting edge	Größe Size [mm]	L1 max. L1 max. [mm]	L L [mm]	L2 L2 [mm]	D2 D2 [mm]	D (h6) D (h6) [mm]	Schaft Shank
F2004NN*2000R0.30..	DA	20,00	R	0,30	38	105	52	19	20	HA/S-λ/HB
F2004NN*2000R0.50..	DA	20,00	R	0,50	38	105	52	19	20	HA/S-λ/HB
F2004NN*2000R0.80..	DA	20,00	R	0,80	38	105	52	19	20	HA/S-λ/HB
F2004NN*2000R1.00..	DA	20,00	R	1,00	38	105	52	19	20	HA/S-λ/HB
F2004NN*2000R1.50..	DA	20,00	R	1,50	38	105	52	19	20	HA/S-λ/HB
F2004NN*2000R2.00..	DA	20,00	R	2,00	38	105	52	19	20	HA/S-λ/HB
F2004NN*2000R3.00..	DA	20,00	R	3,00	38	105	52	19	20	HA/S-λ/HB
F2004NN*2000R4.00..	DA	20,00	R	4,00	38	105	52	19	20	HA/S-λ/HB

* = L - SafeLock / H - Glattschaft / B - Weldonschaft. Bestellnummer = Artikel-Code + Qualität.

* = L - Safe-Lock / H - Straight shank / B - Weldon shank. Order No. = Article Code + Quality.

F2004LL – HAIMER MILL FASE/CHAMFER













Technische Daten und Produkteigenschaften/Technical data and Product characteristics

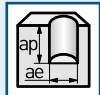

Wahlweise / Optional:

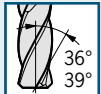
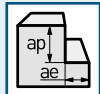
- Glattschaft DIN 6535-HA / Straight shank DIN 6535-HA
- Safe-Lock Schaft (S-λ) / Safe-Lock shank (S-λ)
- Weldonschaft ähnlich DIN 6535-HB / Weldon shank similar DIN 6535-HB

* = H
* = L
* = B

Eigenschaften Characteristics	Anwendung Application	Kühlung Coolant
		
		
		
		
		

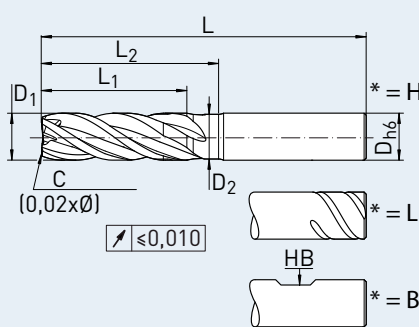

* = H
* = L
* = B

Material – Merkmale/Material – characteristics

Haupteinsatz
Main Material



auch geeignet für
also suitable for

- Halsabsatz für längere Eingriffstiefe
- Zentrumschneide
- Ungleiche Schneidenteilung

- Neck for higher cutting depth
- Center cutting
- Unequal cutting edge

Artikel-Code Article-Code	Qualität Quality	D1 (f9) D1 (f9) [mm]	Schneidecke Cutting edge	Größe Size [mm]	L1 max. L1 max. [mm]	L L [mm]	L2 L2 [mm]	D2 D2 [mm]	D (h6) D (h6) [mm]	Schaft Shank
F2004LL*0600C..	DA	6,00	C	0,12	18	62	24	5,7	6	HA/S-λ/HB
F2004LL*0800C..	DA	8,00	C	0,16	24	70	32	7,6	8	HA/S-λ/HB
F2004LL*1000C..	DA	10,00	C	0,20	30	82	40	9,5	10	HA/S-λ/HB
F2004LL*1200C..	DA	12,00	C	0,24	36	95	48	11,4	12	HA/S-λ/HB
F2004LL*1400C..	DA	14,00	C	0,28	42	105	56	13,3	14	HA/S-λ/HB
F2004LL*1600C..	DA	16,00	C	0,32	48	115	64	15,2	16	HA/S-λ/HB
F2004LL*1800C..	DA	18,00	C	0,36	54	123	72	14,1	18	HA/S-λ/HB
F2004LL*2000C..	DA	20,00	C	0,40	60	133	80	19,0	20	HA/S-λ/HB



* = L - Safe-Lock / H - Glattschaft / B - Weldonschaft. Bestellnummer = Artikel-Code + Qualität.
* = L - Safe-Lock / H - Straight shank / B - Weldon shank. Order No. = Article Code + Quality.

F2014KK – HAIMER MILL FASE/CHAMFER

Schnittdaten/Cutting data

HAIMER Werkstoff Gruppen HAIMER Material groups	Beispiel Werkstoffe Example material	Werkstoffnr. Material no.	Werkstoff Information Material information		Schnittbreite/Cutting width	Schnittgeschwindigkeit Vc (m/min) Cutting speed Vc (m/min)			
			Zugfestigkeit Tensile strength	Inhalt/Härte Content/ Hardness		Rampe Ramping	Schnittgeschwindigkeit Vc (m/min) Cutting speed Vc (m/min)		
P1	Allg. Bau-, Einsatzstähle General construction steels	S235JR (RST37-2), E295 (St 50-2), C45	1.0038, 1.0050, 1.0503	≤ 800 N/mm ²	bis 25 HRC up to 25 HRC	45°	255 – 275	320 – 340	400 – 420
P2	Werkzeug/ Vergütungsstähle Heat treated steels	X38CrMoV5-3, X153CrMoV12, X100CrMoV5, 42CrMo4	1.2367, 1.2379, 1.2363, 1.7225	> 800 N/mm ²	bis 45 HRC up to 45 HRC	30°	190 – 210	220 – 240	290 – 310
M1	Rostfreie Stähle Stainless steels	X8CrNiS18-9, X5CrNi18-10, X46Cr13	1.4305, 1.4301, 1.4034	≤ 650 N/mm ²		10°	95 – 110	115 – 135	150 – 170
M2	Rostfreie Stähle Stainless steels	X6CrNiMoTi17-12-2, X2CrNiMo17-12-2, X4CrNiMo16-5-1	1.4571, 1.4404, 1.4418	> 650 N/mm ²		5°	75 – 90	95 – 105	110 – 130
K1	Gusseisen Cast iron	EN-GJL200 (GG20), EN-GJLZ (GG40), EN-GJS-400-15 (GGG40)	0.6020, 0.6040, 0.7040	≤ 450 N/mm ²		45°	160 – 180	180 – 200	210 – 230
K2	Gusseisen Cast iron	EN-GJS-600-3 (GGG60) EN-GJS-700-2 (GGG70)	0.7060, 0.7070	> 450 N/mm ²		20°	130 – 150	150 – 170	180 – 200
S1	Titan & Titanlegierungen Titanium & titanium alloys	TiAl6V4	3.7165			10°	50 – 60	60 – 80	80 – 90
S2	Warmfeste Legierungen High Temp alloys	Inconel; NIMONIC		800 – 1700 N/mm ²		5°	30 – 40	30 – 40	30 – 40
N1	Alu-Knetlegierungen Wrought aluminum alloys	AlMg1	3.3315		Si < 9%	30°	470 – 490	600 – 630	780 – 820
N2	Alu-Gusslegierungen Aluminum cast alloys	G-AlSi12	3.2581		Si > 9%	30°	340 – 360	420 – 440	540 – 580
H1	Gehärtete Stähle Hardened steels				45 – 55 HRC	10°	40 – 60	60 – 80	60 – 80

Schnittdaten dienen als Richtwerte und müssen dem Bearbeitungsumfeld angepasst werden.
Beim Bohren wird Entspannen je nach Werkstoff, bei 0,5 – 1 x D empfohlen.
Cutting data are reference values and need to be adjusted according to the application area.
Chip removal recommended for drilling depth 0,5 – 1 x D.

Vorschubtable f _z (mm/Zahn) abhängig von D1 und Schnittbreite ae / Feed per tooth (mm/tooth) in relation with D1 and cutting width ae													
ae	ø 2	ø 3	ø 4	ø 5	ø 6	ø 8	ø 10	ø 12	ø 14	ø 16	ø 18	ø 20	
bis/to 50% ø	0,013	0,020	0,026	0,033	0,039	0,052	0,065	0,078	0,091	0,104	0,117	0,13	
100% ø	0,011	0,017	0,022*	0,028*	0,033*	0,044*	0,055*	0,066*	0,077*	0,088*	0,099*	0,11*	
	P	0,009	0,014	0,018	0,023	0,027	0,036	0,045	0,054	0,063	0,072	0,081	0,09
	M	0,005	0,008	0,01	0,013	0,015	0,020	0,025	0,030	0,035	0,040	0,045	0,05
	K	0,008	0,012	0,016	0,020	0,024	0,032	0,040	0,048	0,056	0,064	0,072	0,08
	S	0,004	0,006	0,008	0,010	0,012	0,016	0,020	0,024	0,028	0,032	0,036	0,04
	N	0,009	0,014	0,018	0,023	0,027	0,036	0,045	0,054	0,063	0,072	0,081	0,09

*Beim Nutfräsen (100% ø) im Material M1, M2, S1 und S2 ist der angegebene f_z um 30% zu reduzieren.
*For Slotting (100% ø) in material M1, M2, S1 and S2 reduce f_z by 30%.

F2014KK – HAIMER MILL FASE/CHAMFER

Technische Daten und Produkteigenschaften/Technical data and Product characteristics

Wahlweise / Optional:

- Glattschaft DIN 6535-HA / Straight shank DIN 6535-HA
- Weldonschaft ähnlich DIN 6535-HB / Weldon shank similar DIN 6535-HB

Eigenschaften Characteristics	Anwendung Application	Kühlung Coolant

Material – Merkmale/Material – characteristics



<p>Haupteinsatz Main Material</p> <div style="display: flex; gap: 10px;"> <div style="background-color: #0070C0; color: white; padding: 10px; font-weight: bold; font-size: 24px;">P</div> <div style="background-color: #FFD700; color: white; padding: 10px; font-weight: bold; font-size: 24px;">M</div> </div>	<p>auch geeignet für also suitable for</p> <div style="display: flex; flex-wrap: wrap; gap: 5px;"> <div style="background-color: #C00000; color: white; padding: 5px; font-weight: bold; font-size: 18px;">K</div> <div style="background-color: #FF8C00; color: white; padding: 5px; font-weight: bold; font-size: 18px;">S</div> <div style="background-color: #008000; color: white; padding: 5px; font-weight: bold; font-size: 18px;">N</div> <div style="background-color: #808080; color: white; padding: 5px; font-weight: bold; font-size: 18px;">H</div> </div>	<ul style="list-style-type: none"> ■ Zentrumschneide ■ Ungleiche Schneidenteilung ■ Schneidlänge L1 max 1,25 x D1 ■ Kein Halsabsatz ■ Sehr günstige VHM-Schaftform 	<ul style="list-style-type: none"> ■ Center cutting ■ Unequal cutting edge ■ Cutting length L1 max. 1.25 x D1 ■ No neck ■ Very economical solid carbide shank shape
--	---	---	--

Artikel-Code Article-Code	Qualität Quality	D1 (f9) D1 (f9) [mm]	Schneidecke Cutting edge	Größe Size [mm]	L1 max. L1 max. [mm]	L L [mm]	D (h6) D (h6) [mm]	Schaft Shank h6
F2014KK*0200C..	DA	2,00	C	0,04	2,50	38	6	HA/HB
F2014KK*0300C..	DA	3,00	C	0,06	3,75	38	6	HA/HB
F2014KK*0400C..	DA	4,00	C	0,08	5,00	38	6	HA/HB
F2014KK*0500C..	DA	5,00	C	0,10	6,25	38	6	HA/HB
F2014KK*0600C..	DA	6,00	C	0,12	7,50	38	6	HA/HB
F2014KK*0800C..	DA	8,00	C	0,16	10,00	42	8	HA/HB
F2014KK*1000C..	DA	10,00	C	0,20	12,50	50	10	HA/HB
F2014KK*1200C..	DA	12,00	C	0,24	15,00	55	12	HA/HB
F2014KK*1400C..	DA	14,00	C	0,28	17,50	58	14	HA/HB
F2014KK*1600C..	DA	16,00	C	0,32	20,00	63	16	HA/HB
F2014KK*1800C..	DA	18,00	C	0,36	22,50	70	18	HA/HB
F2014KK*2000C..	DA	20,00	C	0,40	25,00	75	20	HA/HB

* = H - Glattschaft / B - Weldonschaft. Bestellnummer = Artikel-Code + Qualität.
 * = H - Straight shank / B - Weldon shank. Order No. = Article Code + Quality.

F4002NN – HAIMER MILL Alu Series FASE/CHAMFER

Schnittdaten/Cutting data

HAIMER Werkstoff Gruppen HAIMER Material groups	Beispiel Werkstoffe Example material	DIN DIN	Werkstoffnr. Material no.	Werkstoff Information Material information		Schnittbreite/Cutting width		
				Zugfestigkeit Tensile strength	Inhalt/Härte Content/ Hardness			
N1 Alu-Knetlegierungen Wrought aluminum alloys	AlMg1		3.3315		Si < 9%	ae = 100% D1 ap = 1 x D1	ae = 50% D1 ap = 1.5 x D1	ae = 25% D1 ap = L1 max.
N2 Alu-Gusslegierungen Aluminum cast alloys	G-Alsi12		3.2581		Si > 9%			
						300 – 400	400 – 500	500 – 600

Schnittdaten dienen als Richtwerte und müssen dem Bearbeitungsumfeld angepasst werden.
Cutting data are reference values and need to be adjusted according to the application area.

Vorschubtable f _z (mm/Zahn) abhängig von D1 und Schnittbreite ae / Feed per tooth (mm/tooth) in relation with D1 and cutting width ae												
ae	ø 2	ø 3	ø 4	ø 5	ø 6	ø 8	ø 10	ø 12	ø 14	ø 16	ø 18	ø 20
bis/to 50% ø	0,02	0,03	0,04	0,05	0,06	0,08	0,1	0,12	0,14	0,16	0,18	0,2
100% ø	0,01	0,015	0,02	0,025	0,03	0,04	0,05	0,06	0,07	0,08	0,09	0,1
	0,002	0,003	0,004	0,005	0,006	0,008	0,010	0,012	0,014	0,016	0,018	0,020

F4002NN – HAIMER MILL Alu Series FASE/CHAMFER

Technische Daten und Produkteigenschaften/Technical data and Product characteristics



Wahlweise / Optional:

- Glattschaft DIN 6535-HA / Straight shank DIN 6535-HA
- Safe-Lock Schaft (S-λ) / Safe-Lock shank (S-λ)
- Weldonschaft ähnlich DIN 6535-HB / Weldon shank similar DIN 6535-HB



* = H

* = L

* = B

Eigenschaften Characteristics

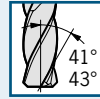
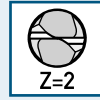

Anwendung Application

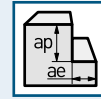
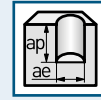

Kühlung Coolant

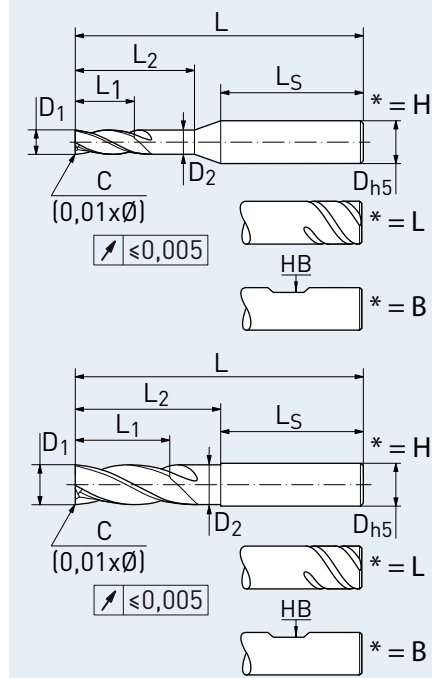

Feingewuchtet/Fine balanced
Ausgenommen Weldonschaft/Except Weldon shank

Material – Merkmale/Material – characteristics

Haupteinsatz
Main Material





- Halsabsatz für längere Eingriffstiefe
- Zentrumschneide
- Polierte Span- und Freiflächen
- Neck for higher cutting depth
- Center cutting
- Polished flute and relief

Artikel-Code Article-Code	Qualität Quality	D1 (h9) D1 (h9) [mm]	Schneidecke Cutting edge	Größe Size [mm]	L1 max. L1 max. [mm]	L L [mm]	L2 L2 [mm]	D2 D2 [mm]	D (h5) D (h5) [mm]	LS LS [mm]	Schaft Shank
F4002NN*0200C..	A-	2,00	C	0,02	7	58	9	1,9	6	44,3	HA/S-λ/HB
F4002NN*0300C..	A-	3,00	C	0,03	8	58	10	2,9	6	44,0	HA/S-λ/HB
F4002NN*0400C..	A-	4,00	C	0,04	11	58	15	3,8	6	40,0	HA/S-λ/HB
F4002NN*0500C..	A-	5,00	C	0,05	13	58	18	4,8	6	37,875	HA/S-λ/HB
F4002NN*0600C..	A-	6,00	C	0,06	13	58	20	5,7	6	36,5	HA/S-λ/HB
F4002NN*0800C..	A-	8,00	C	0,08	19	64	26	7,6	8	36,5	HA/S-λ/HB
F4002NN*1000C..	A-	10,00	C	0,10	22	73	30,5	9,5	10	40,5	HA/S-λ/HB
F4002NN*1200C..	A-	12,00	C	0,12	26	84	36,5	11,4	12	45,5	HA/S-λ/HB
F4002NN*1400C..	A-	14,00	C	0,14	26	84	36,5	13,3	14	45,5	HA/S-λ/HB
F4002NN*1600C..	A-	16,00	C	0,16	32	93	42,5	15,2	16	48,5	HA/S-λ/HB
F4002NN*1800C..	A-	18,00	C	0,18	32	93	42,5	17,1	18	48,5	HA/S-λ/HB
F4002NN*2000C..	A-	20,00	C	0,20	38	105	52	19	20	50,5	HA/S-λ/HB

* = L - Safe-Lock / H - Glattschaft / B - Weldonschaft. Bestellnummer = Artikel-Code + Qualität.
* = L - Safe-Lock / H - Straight shank / B - Weldon shank. Order No. = Article Code + Quality.

F4002NN – HAIMER MILL Alu Series FASE/CHAMFER

Schnittdaten/Cutting data

HAIMER Werkstoff Gruppen HAIMER Material groups	Beispiel Werkstoffe Example material	Werkstoffnr. Material no.	Werkstoff Information Material information		Schnittbreite/Cutting width			
			Zugfestigkeit Tensile strength	Inhalt/Härte Content/ Hardness				
					Schnittgeschwindigkeit Vc (m/min) Cutting speed Vc (m/min)			
N1	Alu-Knetlegierungen Wrought aluminum alloys	AlMg1	3.3315		Si < 9%	300 – 400	400 – 500	500 – 600
N2	Alu-Gusslegierungen Aluminum cast alloys	G-Alsi12	3.2581		Si > 9%			

Schnittdaten dienen als Richtwerte und müssen dem Bearbeitungsumfeld angepasst werden.
Cutting data are reference values and need to be adjusted according to the application area.

Vorschubtable f _z (mm/Zahn) abhängig von D1 und Schnittbreite ae /Feed per tooth (mm/tooth) in relation with D1 and cutting width ae												
ae	ø 2	ø 3	ø 4	ø 5	ø 6	ø 8	ø 10	ø 12	ø 14	ø 16	ø 18	ø 20
bis/to 50% ø	0,02	0,03	0,04	0,05	0,06	0,08	0,1	0,12	0,14	0,16	0,18	0,2
100% ø	0,01	0,015	0,02	0,025	0,03	0,04	0,05	0,06	0,07	0,08	0,09	0,1
	0,002	0,003	0,004	0,005	0,006	0,008	0,010	0,012	0,014	0,016	0,018	0,020

F4002NN – HAIMER MILL Alu Series FASE/CHAMFER

Technische Daten und Produkteigenschaften/Technical data and Product characteristics



Wahlweise / Optional:

- Glattschaft DIN 6535-HA / Straight shank DIN 6535-HA
- Safe-Lock Schaft (S-λ) / Safe-Lock shank (S-λ)
- Weldonschaft ähnlich DIN 6535-HB / Weldon shank similar DIN 6535-HB

* = H

* = L

* = B

Eigenschaften Characteristics

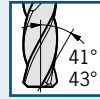
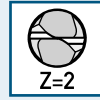

Anwendung Application

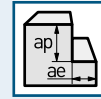
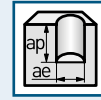

Kühlung Coolant

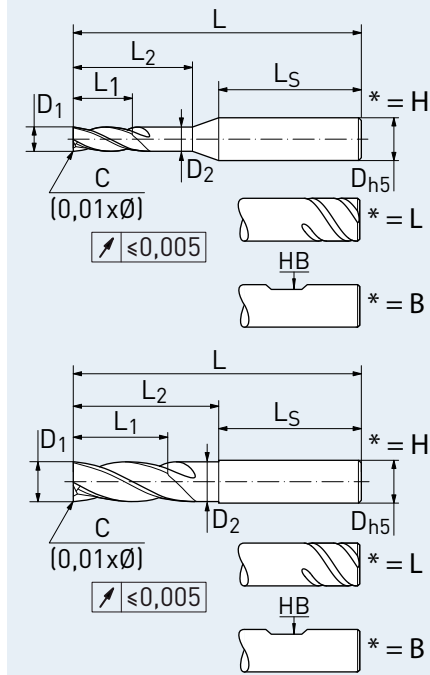

Feingewuchtet/Fine balanced
Ausgenommen Weldonschaft/Except Weldon shank

Material – Merkmale/Material – characteristics

Haupteinsatz
Main Material





- Beschichtung für abrasive Werkstoffe
- Halsabsatz für längere Eingriffstiefe
- Zentrumschneide
- Polierte Span- und Freiflächen
- Coating for abrasive materials
- Neck for higher cutting depth
- Center cutting
- Polished flute and relief

Artikel-Code Article-Code	Qualität Quality	D1 (h9) D1 (h9) [mm]	Schneidecke Cutting edge	Größe Size [mm]	L1 max. L1 max. [mm]	L L [mm]	L2 L2 [mm]	D2 D2 [mm]	D (h5) D (h5) [mm]	LS LS [mm]	Schaft Shank
F4002NN*0200C..	AC	2,00	C	0,02	7	58	9	1,9	6	44,3	HA/S-λ/HB
F4002NN*0300C..	AC	3,00	C	0,03	8	58	10	2,9	6	44,0	HA/S-λ/HB
F4002NN*0400C..	AC	4,00	C	0,04	11	58	15	3,8	6	40,0	HA/S-λ/HB
F4002NN*0500C..	AC	5,00	C	0,05	13	58	18	4,8	6	37,875	HA/S-λ/HB
F4002NN*0600C..	AC	6,00	C	0,06	13	58	20	5,7	6	36,5	HA/S-λ/HB
F4002NN*0800C..	AC	8,00	C	0,08	19	64	26	7,6	8	36,5	HA/S-λ/HB
F4002NN*1000C..	AC	10,00	C	0,10	22	73	30,5	9,5	10	40,5	HA/S-λ/HB
F4002NN*1200C..	AC	12,00	C	0,12	26	84	36,5	11,4	12	45,5	HA/S-λ/HB
F4002NN*1400C..	AC	14,00	C	0,14	26	84	36,5	13,3	14	45,5	HA/S-λ/HB
F4002NN*1600C..	AC	16,00	C	0,16	32	93	42,5	15,2	16	48,5	HA/S-λ/HB
F4002NN*1800C..	AC	18,00	C	0,18	32	93	42,5	17,1	18	48,5	HA/S-λ/HB
F4002NN*2000C..	AC	20,00	C	0,20	38	105	52	19	20	50,5	HA/S-λ/HB

* = L - Safe-Lock / H - Glattschaft / B - Weldonschaft. Bestellnummer = Artikel-Code + Qualität.
* = L - Safe-Lock / H - Straight shank / B - Weldon shank. Order No. = Article Code + Quality.

F4003NN – HAIMER MILL Alu Series FASE/CHAMFER

Schnittdaten/Cutting data

HAIMER Werkstoff Gruppen HAIMER Material groups	Beispiel Werkstoffe Example material	DIN DIN	Werkstoffnr. Material no.	Werkstoff Information Material information		Schnittbreite/Cutting width		
				Zugfestigkeit Tensile strength	Inhalt/Härte Content/ Hardness			
N1 Alu-Knetlegierungen Wrought aluminum alloys	AlMg1		3.3315		Si < 9%	ae = 100% D1 ap = 1 x D1	ae = 50% D1 ap = 1.5 x D1	ae = 25% D1 ap = L1 max.
N2 Alu-Gusslegierungen Aluminum cast alloys	G-Alsi12		3.2581		Si > 9%			
						300 – 400	400 – 500	500 – 600

Schnittdaten dienen als Richtwerte und müssen dem Bearbeitungsumfeld angepasst werden.
Cutting data are reference values and need to be adjusted according to the application area.

Vorschubtable f _z (mm/Zahn) abhängig von D1 und Schnittbreite ae /Feed per tooth (mm/tooth) in relation with D1 and cutting width ae												
ae	ø 2	ø 3	ø 4	ø 5	ø 6	ø 8	ø 10	ø 12	ø 14	ø 16	ø 18	ø 20
bis/to 50% ø	0,02	0,03	0,04	0,05	0,06	0,08	0,1	0,12	0,14	0,16	0,18	0,2
100% ø	0,01	0,015	0,02	0,025	0,03	0,04	0,05	0,06	0,07	0,08	0,09	0,1
	0,002	0,003	0,004	0,005	0,006	0,008	0,010	0,012	0,014	0,016	0,018	0,020

F4003NN – HAIMER MILL Alu Series FASE/CHAMFER

Technische Daten und Produkteigenschaften/Technical data and Product characteristics



Wahlweise / Optional:

- Glattschaft DIN 6535-HA / Straight shank DIN 6535-HA
- Safe-Lock Schaft (S-λ) / Safe-Lock shank (S-λ)
- Weldonschaft ähnlich DIN 6535-HB / Weldon shank similar DIN 6535-HB



* = H

* = L

* = B

Eigenschaften Characteristics

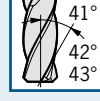

Anwendung Application

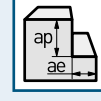
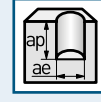
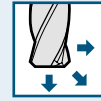

Kühlung Coolant

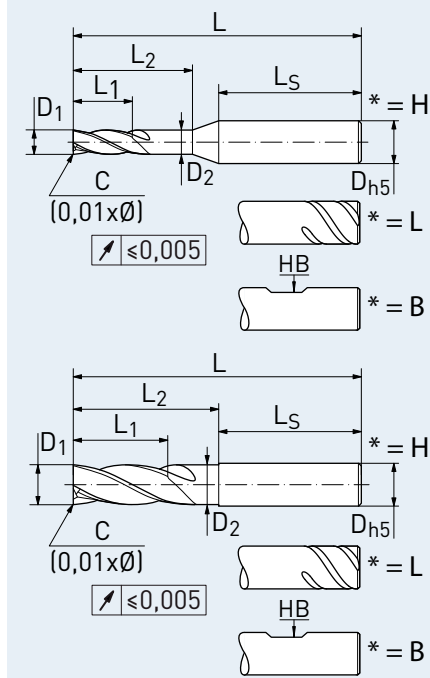

Feingewuchtet/Fine balanced
Ausgenommen Weldonschaft/Except Weldon shank

Material – Merkmale/Material – characteristics

Haupteinsatz
Main Material





- Halsabsatz für längere Eingriffstiefe
- Zentrumschneide
- Polierte Span- und Freiflächen
- Neck for higher cutting depth
- Center cutting
- Polished flute and relief

Artikel-Code Article-Code	Qualität Quality	D1 (h9) D1 (h9) [mm]	Schneidecke Cutting edge	Größe Size [mm]	L1 max. L1 max. [mm]	L L [mm]	L2 L2 [mm]	D2 D2 [mm]	D (h5) D (h5) [mm]	LS LS [mm]	Schaft Shank
F4003NN*0200C..	A-	2,00	C	0,02	7	58	9	1,9	6	44,3	HA/S-λ/HB
F4003NN*0300C..	A-	3,00	C	0,03	8	58	10	2,9	6	44,0	HA/S-λ/HB
F4003NN*0400C..	A-	4,00	C	0,04	11	58	15	3,8	6	40,0	HA/S-λ/HB
F4003NN*0500C..	A-	5,00	C	0,05	13	58	18	4,8	6	37,875	HA/S-λ/HB
F4003NN*0600C..	A-	6,00	C	0,06	13	58	20	5,7	6	36,5	HA/S-λ/HB
F4003NN*0800C..	A-	8,00	C	0,08	19	64	26	7,6	8	36,5	HA/S-λ/HB
F4003NN*1000C..	A-	10,00	C	0,10	22	73	30,5	9,5	10	40,5	HA/S-λ/HB
F4003NN*1200C..	A-	12,00	C	0,12	26	84	36,5	11,4	12	45,5	HA/S-λ/HB
F4003NN*1400C..	A-	14,00	C	0,14	26	84	36,5	13,3	14	45,5	HA/S-λ/HB
F4003NN*1600C..	A-	16,00	C	0,16	32	93	42,5	15,2	16	48,5	HA/S-λ/HB
F4003NN*1800C..	A-	18,00	C	0,18	32	93	42,5	17,1	18	48,5	HA/S-λ/HB
F4003NN*2000C..	A-	20,00	C	0,20	41	105	52	19	20	50,5	HA/S-λ/HB

* = L - Safe-Lock / H - Glattschaft / B - Weldonschaft. Bestellnummer = Artikel-Code + Qualität.
* = L - Safe-Lock / H - Straight shank / B - Weldon shank. Order No. = Article Code + Quality.

F4003NN – HAIMER MILL Alu Series FASE/CHAMFER

Schnittdaten/Cutting data

HAIMER Werkstoff Gruppen HAIMER Material groups	Beispiel Werkstoffe Example material	DIN DIN	Werkstoffnr. Material no.	Werkstoff Information Material information		Schnittbreite/Cutting width		
				Zugfestigkeit Tensile strength	Inhalt/Härte Content/ Hardness			
N1 Alu-Knetlegierungen Wrought aluminum alloys	AlMg1		3.3315		Si < 9%	ae = 100% D1 ap = 1 x D1	ae = 50% D1 ap = 1.5 x D1	ae = 25% D1 ap = L1 max.
N2 Alu-Gusslegierungen Aluminum cast alloys	G-Alsi12		3.2581		Si > 9%			
						300 – 400	400 – 500	500 – 600

Schnittdaten dienen als Richtwerte und müssen dem Bearbeitungsumfeld angepasst werden.
Cutting data are reference values and need to be adjusted according to the application area.

Vorschubtable f _z (mm/Zahn) abhängig von D1 und Schnittbreite ae /Feed per tooth (mm/tooth) in relation with D1 and cutting width ae												
ae	ø 2	ø 3	ø 4	ø 5	ø 6	ø 8	ø 10	ø 12	ø 14	ø 16	ø 18	ø 20
bis/to 50% ø	0,02	0,03	0,04	0,05	0,06	0,08	0,1	0,12	0,14	0,16	0,18	0,2
100% ø	0,01	0,015	0,02	0,025	0,03	0,04	0,05	0,06	0,07	0,08	0,09	0,1
	0,002	0,003	0,004	0,005	0,006	0,008	0,010	0,012	0,014	0,016	0,018	0,020

F4003NN – HAIMER MILL Alu Series FASE/CHAMFER

Technische Daten und Produkteigenschaften/Technical data and Product characteristics



Wahlweise / Optional:

- Glattschaft DIN 6535-HA / Straight shank DIN 6535-HA
- Safe-Lock Schaft (S-λ) / Safe-Lock shank (S-λ)
- Weldonschaft ähnlich DIN 6535-HB / Weldon shank similar DIN 6535-HB



* = H

* = L

* = B

Eigenschaften Characteristics

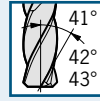

Anwendung Application

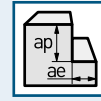
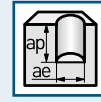
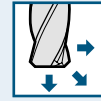

Kühlung Coolant

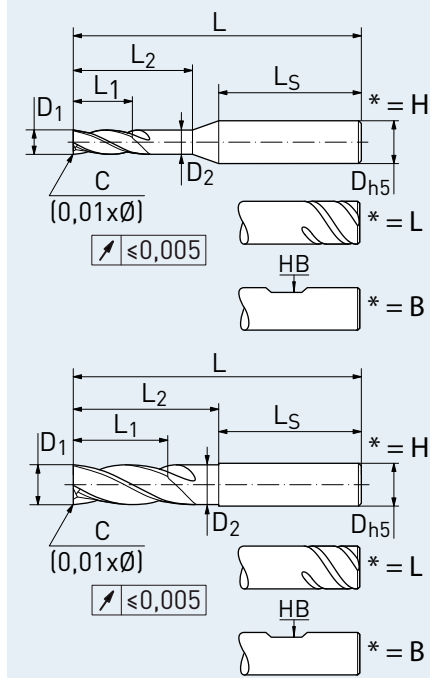

Feingewuchtet/Fine balanced
Ausgenommen Weldonschaft/Except Weldon shank

Material – Merkmale/Material – characteristics

Haupteinsatz
Main Material



- Beschichtung für abrasive Werkstoffe
- Halsabsatz für längere Eingriffstiefe
- Zentrumschneide
- Polierte Span- und Freiflächen
- Coating for abrasive materials
- Neck for higher cutting depth
- Center cutting
- Polished flute and relief

Artikel-Code Article-Code	Qualität Quality	D1 (h9) D1 (h9) [mm]	Schneidecke Cutting edge	Größe Size [mm]	L1 max. L1 max. [mm]	L L [mm]	L2 L2 [mm]	D2 D2 [mm]	D (h5) D (h5) [mm]	LS LS [mm]	Schaft Shank
F4003NN*0200C..	AC	2,00	C	0,02	7	58	9	1,9	6	44,3	HA/S-λ/HB
F4003NN*0300C..	AC	3,00	C	0,03	8	58	10	2,9	6	44,0	HA/S-λ/HB
F4003NN*0400C..	AC	4,00	C	0,04	11	58	15	3,8	6	40,0	HA/S-λ/HB
F4003NN*0500C..	AC	5,00	C	0,05	13	58	18	4,8	6	37,875	HA/S-λ/HB
F4003NN*0600C..	AC	6,00	C	0,06	13	58	20	5,7	6	36,5	HA/S-λ/HB
F4003NN*0800C..	AC	8,00	C	0,08	19	64	26	7,6	8	36,5	HA/S-λ/HB
F4003NN*1000C..	AC	10,00	C	0,10	22	73	30,5	9,5	10	40,5	HA/S-λ/HB
F4003NN*1200C..	AC	12,00	C	0,12	26	84	36,5	11,4	12	45,5	HA/S-λ/HB
F4003NN*1400C..	AC	14,00	C	0,14	26	84	36,5	13,3	14	45,5	HA/S-λ/HB
F4003NN*1600C..	AC	16,00	C	0,16	32	93	42,5	15,2	16	48,5	HA/S-λ/HB
F4003NN*1800C..	AC	18,00	C	0,18	32	93	42,5	17,1	18	48,5	HA/S-λ/HB
F4003NN*2000C..	AC	20,00	C	0,20	41	105	52	19	20	50,5	HA/S-λ/HB

* = L - Safe-Lock / H - Glattschaft / B - Weldonschaft. Bestellnummer = Artikel-Code + Qualität.
* = L - Safe-Lock / H - Straight shank / B - Weldon shank. Order No. = Article Code + Quality.

H2004KN – HAIMER MILL HF Series HOCHVORSCHUB KZ/HIGH FEED KZ

Schnittdaten/Cutting data

HAIMER Werkstoff Gruppen HAIMER Material groups		Beispiel Werkstoffe Example material		Werkstoff Information Material information		Schruppen Vc (m/min) Roughing Vc (m/min)	Schlichten Vc (m/min) Finishing Vc (m/min)
		DIN DIN	Werkstoffnr. Material no.	Zugfestigkeit Tensile strength	Inhalt/Härte Content/ Hardness		
P1	Allg. Bau-, Einsatzstähle General construction steels	S235JR (RST37-2), E295 (St 50-2), C45	1.0038, 1.0050, 1.0503	≤ 800 N/mm ²	bis 25 HRC up to 25 HRC	250 – 320	340 – 420
P2	Werkzeug/ Vergütungsstähle Heat treated steels	X38CrMoV5-3, X153CrMoV12, X100CrMoV5, 42CrMo4	1.2367, 1.2379, 1.2363, 1.7225	> 800 N/mm ²	bis 45 HRC up to 45 HRC	190 – 220	240 – 310
M1	Rostfreie Stähle Stainless steels	X8CrNiS18-9, X5CrNi18-10, X46Cr13	1.4305, 1.4301, 1.4034	≤ 650 N/mm ²		95 – 115	135 – 170
M2	Rostfreie Stähle Stainless steels	X6CrNiMoTi17-12-2, X2CrNiMo17-12-2, X4CrNiMo16-5-1	1.4571, 1.4404, 1.4418	> 650 N/mm ²		75 – 95	105 – 130
K1	Gusseisen Cast iron	EN-GJL200 (GG20), EN-GJLZ (GG40), EN- GJS-400-15 (GGG40)	0.6020, 0.6040, 0.7040	≤ 450 N/mm ²		160 – 180	200 – 230
K2	Gusseisen Cast iron	EN-GJS-600-3 (GGG60), EN-GJS-700-2 (GGG70)	0.7060, 0.7070	> 450 N/mm ²		130 – 150	170 – 200
S1	Titan & Titanlegierungen Titanium & titanium alloys	TiAl6V4	3.7165			50 – 60	80 – 90
S2	Warmfeste Legierungen High Temp alloys	Inconel; NIMONIC		800 – 1700 N/mm ²		30 – 40	30 – 40
N1	Alu-Knetlegierungen Wrought aluminum alloys	AlMg1	3.3315		Si < 9%	500 – 900	500 – 900
N2	Alu-Gusslegierungen Aluminum cast alloys	G-Alsi12	3.2581		Si > 9%	120 – 350	120 – 350
H1	Gehärtete Stähle Hardened steels				45 – 55 HRC	40 – 60	60 – 80

Schnittdaten dienen als Richtwerte und müssen dem Bearbeitungsumfeld angepasst werden.
 Cutting data are reference values and need to be adjusted according to the application area.

Vorschubtable f _z (mm/Zahn) abhängig von D1 und Schnittbreite a _e / Feed per tooth (mm/tooth) in relation with D1 and cutting width a _e			
	∅ 6	∅ 8	∅ 10
f _z	0,06 – 0,18	0,08 – 0,24	0,1 – 0,3
a _p HFC	0,45	0,6	0,75

Schnittdaten Basis zylindrische Verlängerung kurz, Schnittdaten bei längeren Auskragungen anpassen.
 Cutting data is based on cylindrical extensions short, cutting data for long overhang need to be adjusted.

H2004KN – HAIMER MILL HF Series HOCHVORSCHUB KZ/HIGH FEED KZ

Technische Daten und Produkteigenschaften/Technical data and Product characteristics



Eigenschaften Characteristics	Anwendung Application	Kühlung Coolant
1.25 × Ø		
R	10°	Air
Z=4	ap, ae	
20°		
HA		

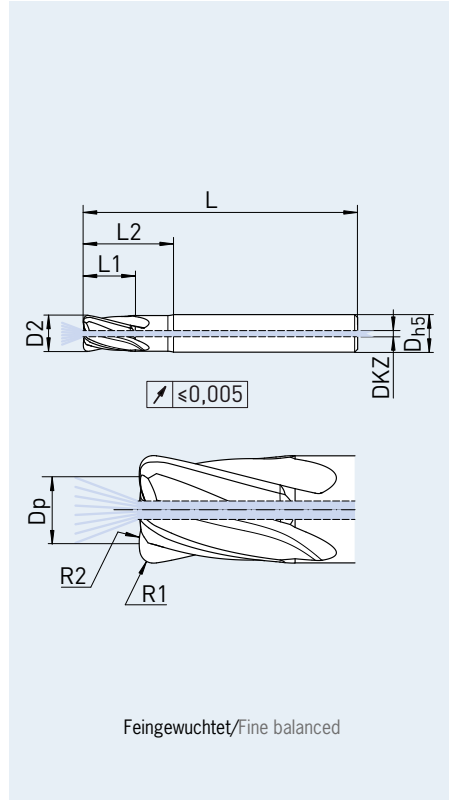

Material – Merkmale/Material – characteristics

Haupteinsatz
Main Material



auch geeignet für
also suitable for



- Innenkühlung zentral
- Halsabsatz für längere Eingriffstiefe

- Central inner cooling
- Neck for higher cutting depth

Artikel-Code Article-Code	Qualität Quality	D1 (f9) D1 (f9) [mm]	Schneidecke Cutting edge	R1 R1 [mm]	R2 R2 [mm]	Dp Dp [mm]	L1 max. L1 max. [mm]	L L [mm]	L2 L2 [mm]	DKZ DKZ [mm]	D2 D2 [mm]	D (h5) D (h5) [mm]	Schaft Shank
H2004KNH0600R..	DAKZ	6,00	R	0,9	3,00	1,80	7,50	58	15	1,0	5,7	6	HA
H2004KNH0800R..	DAKZ	8,00	R	1,2	4,00	4,80	10,00	64	19,5	1,3	7,6	8	HA
H2004KNH1000R..	DAKZ	10,00	R	1,5	5,00	6,00	12,50	73	24	2,0	9,5	10	HA

Bestellnummer = Artikel-Code + Qualität.
Order No. = Article Code + Quality.

V1002NN – HAIMER MILL Power Series VOLLRADIUS/BALL NOSE

Schnittdaten/Cutting data

HAIMER Werkstoff Gruppen HAIMER Material groups	Beispiel Werkstoffe Example material	Werkstoffnr. Material no.	Werkstoff Information Material information		Schruppen Vc (m/min) Roughing Vc (m/min)	Schlichten Vc (m/min) Finishing Vc (m/min)	
			Zugfestigkeit Tensile strength	Inhalt/Härte Content/ Hardness			
P1	Allg. Bau-, Einsatzstähle General construction steels	S235JR (RST37-2), E295 (St 50-2), C45	1.0038, 1.0050, 1.0503	≤ 800 N/mm ²	bis 25 HRC up to 25 HRC	180 – 220	280 – 320
P2	Werkzeug-/Vergütungsstähle Heat treated steels	X38CrMoV5-3, X153CrMoV12, X100CrMoV5, 42CrMo4	1.2367, 1.2379, 1.2363, 1.7225	> 800 N/mm ²	bis 45 HRC up to 45 HRC	170 – 190	270 – 290
M1	Rostfreie Stähle Stainless steels	X8CrNiS18-9, X5CrNi18-10, X46Cr13	1.4305, 1.4301, 1.4034	≤ 650 N/mm ²		110 – 130	170 – 190
M2	Rostfreie Stähle Stainless steels	X6CrNiMoTi17-12-2, X2CrNiMo17-12-2, X4CrNiMo16-5-1	1.4571, 1.4404, 1.4418	> 650 N/mm ²		70 – 90	120 – 140
K1	Gusseisen Cast iron	EN-GJL200 (GG20), EN-GJLZ (GG40), EN-GJS-400-15 (GGG40)	0.6020, 0.6040, 0.7040	≤ 450 N/mm ²		190 – 210	290 – 310
K2	Gusseisen Cast iron	EN-GJS-600-3 (GGG60), EN-GJS-700-2 (GGG70)	0.7060, 0.7070	> 450 N/mm ²		140 – 160	220 – 240
S1	Titan & Titanlegierungen Titanium & titanium alloys	TiAl6V4	3.7165			60 – 80	60 – 80
S2	Wärmefeste Legierungen High Temp alloys	Inconel; NIMONIC		800 – 1700 N/mm ²		30 – 40	30 – 40
N1	Alu-Knetlegierungen Wrought aluminum alloys	AlMg1	3.3315		Si < 9%	120 – 240	120 – 240
N2	Alu-Gusslegierungen Aluminum cast alloys	G-Alsi12	3.2581		Si > 9%	120 – 240	120 – 240
H1	Gehärtete Stähle Hardened steels				45 – 55 HRC	40 – 60	60 – 80

Schnittdaten dienen als Richtwerte und müssen dem Bearbeitungsumfeld angepasst werden.
Cutting data are reference values and need to be adjusted according to the application area.

Vorschubtable f _z (mm/Zahn) abhängig von D1 und Schnittbreite ae / Feed per tooth (mm/tooth) in relation with D1 and cutting width ae												
ae	ø 2	ø 3	ø 4	ø 5	ø 6	ø 8	ø 10	ø 12	ø 14	ø 16	ø 18	ø 20
bis/to 50% ø	0,02	0,03	0,04	0,05	0,06	0,08	0,1	0,12	0,14	0,16	0,18	0,2
100% ø	0,01	0,015	0,02	0,025	0,03	0,04	0,05	0,06	0,07	0,08	0,09	0,1
	0,002	0,003	0,004	0,005	0,006	0,008	0,010	0,012	0,014	0,016	0,018	0,020

V1002NN – HAIMER MILL Power Series VOLLRADIUS/BALL NOSE

Technische Daten und Produkteigenschaften/Technical data and Product characteristics









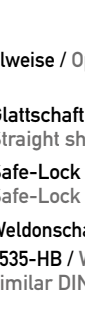





Wahlweise / Optional:

- Glattschaft DIN 6535-HA / Straight shank DIN 6535-HA
- Safe-Lock Schaft (S-λ) / Safe-Lock shank (S-λ)
- Weldonschaft ähnlich DIN 6535-HB / Weldon shank similar DIN 6535-HB

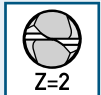
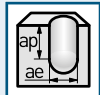
* = H

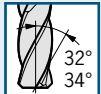
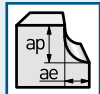
* = L

* = B

Eigenschaften Characteristics	Anwendung Application	Kühlung Coolant
		
		
		
		
		

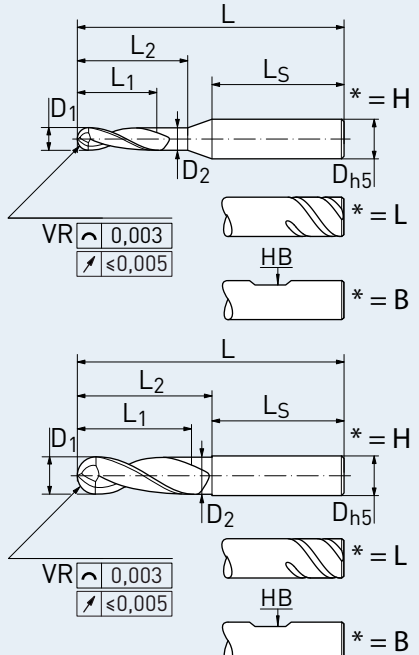

Feingewuchtet/Fine balanced
Ausgenommen Weldonschaft/Except Weldon shank

Material – Merkmale/Material – characteristics

Haupteinsatz
Main Material



auch geeignet für
also suitable for



- Halsabsatz für längere Eingriffstiefe
- Vollradius
- Polierte Span- und Freiflächen



- Neck for higher cutting depth
- Ball Nose
- Polished flute and relief

Artikel-Code Article-Code	Qualität Quality	D1 D1 [mm]	VR VR ± 0,005 mm	L1 max. L1 max. [mm]	L L [mm]	L2 L2 [mm]	D2 D2 [mm]	D (h5) D (h5) [mm]	LS LS [mm]	Schaft Shank	
V1002NN*0200R..	AA	2	-0,005 -0,025	0,9925	7	58	9	1,9	6	44,3	HA/S-λ/HB
V1002NN*0300R..	AA	3	-0,005 -0,025	1,4925	8	58	10	2,9	6	44,0	HA/S-λ/HB
V1002NN*0400R..	AA	4	-0,010 -0,030	1,99	11	58	15	3,8	6	40,0	HA/S-λ/HB
V1002NN*0500R..	AA	5	-0,010 -0,030	2,49	13	58	18	4,8	6	37,875	HA/S-λ/HB
V1002NN*0600R..	AA	6	-0,010 -0,030	2,99	13	58	20	5,7	6	36,5	HA/S-λ/HB
V1002NN*0800R..	AA	8	-0,010 -0,030	3,99	19	64	26	7,6	8	36,5	HA/S-λ/HB
V1002NN*1000R..	AA	10	-0,010 -0,030	4,99	22	73	30,5	9,5	10	40,5	HA/S-λ/HB
V1002NN*1200R..	AA	12	-0,010 -0,030	5,99	26	84	36,5	11,4	12	45,5	HA/S-λ/HB
V1002NN*1400R..	AA	14	-0,010 -0,030	6,99	26	84	36,5	13,3	14	45,5	HA/S-λ/HB
V1002NN*1600R..	AA	16	-0,010 -0,030	7,99	32	93	42,5	15,2	16	48,5	HA/S-λ/HB
V1002NN*1800R..	AA	18	-0,010 -0,030	8,99	32	93	42,5	17,1	18	48,5	HA/S-λ/HB
V1002NN*2000R..	AA	20	-0,010 -0,030	9,99	38	105	52	19	20	50,5	HA/S-λ/HB

* = L - Safe-Lock / H - Glattschaft / B - Weldonschaft. Bestellnummer = Artikel-Code + Qualität.
* = L - Safe-Lock / H - Straight shank / B - Weldon shank. Order No. = Article Code + Quality.

V4002NN – HAIMER MILL Alu Series VOLLRADIUS/BALL NOSE

Schnittdaten/Cutting data

HAIMER Werkstoff Gruppen HAIMER Material groups	Beispiel Werkstoffe Example material	Werkstoffnr. Material no.	Werkstoff Information Material information		Schnittbreite/Cutting width					
			Zugfestigkeit Tensile strength	Inhalt/Härte Content/ Hardness				Schnittgeschwindigkeit Vc (m/min) Cutting speed Vc (m/min)		
N1 Alu-Knetlegierungen Wrought aluminum alloys	AlMg1	3.3315		Si < 9%	ae = 100% D1 ap = 1 x D1	ae = 50% D1 ap = 1.5 x D1	ae = 25% D1 ap = L1 max.	300 – 400	400 – 500	500 – 600
N2 Alu-Gusslegierungen Aluminum cast alloys	G-Alsi12	3.2581		Si > 9%						

Schnittdaten dienen als Richtwerte und müssen dem Bearbeitungsumfeld angepasst werden.
Cutting data are reference values and need to be adjusted according to the application area.

Vorschubtable f _z (mm/Zahn) abhängig von D1 und Schnittbreite ae /Feed per tooth (mm/tooth) in relation with D1 and cutting width ae												
ae	∅ 2	∅ 3	∅ 4	∅ 5	∅ 6	∅ 8	∅ 10	∅ 12	∅ 14	∅ 16	∅ 18	∅ 20
bis/to 50% ∅	0,02	0,03	0,04	0,05	0,06	0,08	0,1	0,12	0,14	0,16	0,18	0,2
100% ∅	0,01	0,015	0,02	0,025	0,03	0,04	0,05	0,06	0,07	0,08	0,09	0,1
	0,002	0,003	0,004	0,005	0,006	0,008	0,010	0,012	0,014	0,016	0,018	0,020

V4002NN – HAIMER MILL Alu Series VOLLRADIUS/BALL NOSE

Technische Daten und Produkteigenschaften/Technical data and Product characteristics



Wahlweise / Optional:

- Glattschaft DIN 6535-HA / Straight shank DIN 6535-HA
- Safe-Lock Schaft (S-λ) / Safe-Lock shank (S-λ)
- Weldonschaft ähnlich DIN 6535-HB / Weldon shank similar DIN 6535-HB



* = H

* = L

* = B

Eigenschaften Characteristics

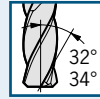
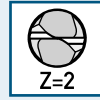

Anwendung Application

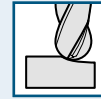
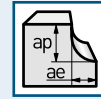
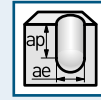

Kühlung Coolant

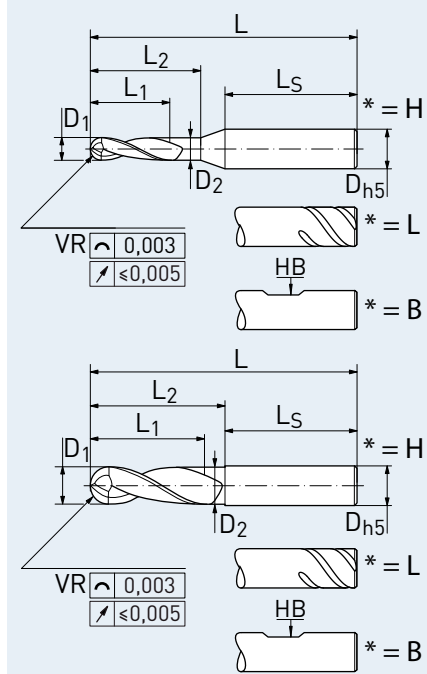

Feingewuchtet/Fine balanced
Ausgenommen Weldonschaft/Except Weldon shank

Material – Merkmale/Material – characteristics

Haupteinsatz
Main Material



- Halsabsatz für längere Eingriffstiefe
- Vollradius
- Polierte Span- und Freiflächen
- Neck for higher cutting depth
- Ball Nose
- Polished flute and relief



Artikel-Code Article-Code	Qualität Quality	D1 D1 [mm]	VR VR ± 0,005 mm	L1 max. L1 max. [mm]	L L [mm]	L2 L2 [mm]	D2 D2 [mm]	D (h5) D (h5) [mm]	LS LS [mm]	Schaft Shank	
V4002NN*0200R..	A-	2	$-0,005$ $-0,025$	0,9925	7	58	9	1,9	6	44,3	HA/S-λ/HB
V4002NN*0300R..	A-	3	$-0,005$ $-0,025$	1,4925	8	58	10	2,9	6	44,0	HA/S-λ/HB
V4002NN*0400R..	A-	4	$-0,010$ $-0,030$	1,99	11	58	15	3,8	6	40,0	HA/S-λ/HB
V4002NN*0500R..	A-	5	$-0,010$ $-0,030$	2,49	13	58	18	4,8	6	37,875	HA/S-λ/HB
V4002NN*0600R..	A-	6	$-0,010$ $-0,030$	2,99	13	58	20	5,7	6	36,5	HA/S-λ/HB
V4002NN*0800R..	A-	8	$-0,010$ $-0,030$	3,99	19	64	26	7,6	8	36,5	HA/S-λ/HB
V4002NN*1000R..	A-	10	$-0,010$ $-0,030$	4,99	22	73	30,5	9,5	10	40,5	HA/S-λ/HB
V4002NN*1200R..	A-	12	$-0,010$ $-0,030$	5,99	26	84	36,5	11,4	12	45,5	HA/S-λ/HB
V4002NN*1400R..	A-	14	$-0,010$ $-0,030$	6,99	26	84	36,5	13,3	14	45,5	HA/S-λ/HB
V4002NN*1600R..	A-	16	$-0,010$ $-0,030$	7,99	32	93	42,5	15,2	16	48,5	HA/S-λ/HB
V4002NN*1800R..	A-	18	$-0,010$ $-0,030$	8,99	32	93	42,5	17,1	18	48,5	HA/S-λ/HB
V4002NN*2000R..	A-	20	$-0,010$ $-0,030$	9,99	38	105	52	19	20	50,5	HA/S-λ/HB

* = L - Safe-Lock / H - Glattschaft / B - Weldonschaft. Bestellnummer = Artikel-Code + Qualität.

* = L - Safe-Lock / H - Straight shank / B - Weldon shank. Order No. = Article Code + Quality.

V4002NN – HAIMER MILL Alu Series VOLLRADIUS/BALL NOSE

Schnittdaten/Cutting data

HAIMER Werkstoff Gruppen HAIMER Material groups	Beispiel Werkstoffe Example material	Werkstoffnr. Material no.	Werkstoff Information Material information		Schnittbreite/Cutting width					
			Zugfestigkeit Tensile strength	Inhalt/Härte Content/ Hardness				Schnittgeschwindigkeit Vc (m/min) Cutting speed Vc (m/min)		
N1 Alu-Knetlegierungen Wrought aluminum alloys	AlMg1	3.3315		Si < 9%	ae = 100% D1 ap = 1 x D1	ae = 50% D1 ap = 1.5 x D1	ae = 25% D1 ap = L1 max.	300 – 400	400 – 500	500 – 600
N2 Alu-Gusslegierungen Aluminum cast alloys	G-Alsi12	3.2581		Si > 9%						

Schnittdaten dienen als Richtwerte und müssen dem Bearbeitungsumfeld angepasst werden.
Cutting data are reference values and need to be adjusted according to the application area.

Vorschubtable f _z (mm/Zahn) abhängig von D1 und Schnittbreite ae / Feed per tooth (mm/tooth) in relation with D1 and cutting width ae												
ae	ø 2	ø 3	ø 4	ø 5	ø 6	ø 8	ø 10	ø 12	ø 14	ø 16	ø 18	ø 20
bis/to 50% ø	0,02	0,03	0,04	0,05	0,06	0,08	0,1	0,12	0,14	0,16	0,18	0,2
100% ø	0,01	0,015	0,02	0,025	0,03	0,04	0,05	0,06	0,07	0,08	0,09	0,1
	0,002	0,003	0,004	0,005	0,006	0,008	0,010	0,012	0,014	0,016	0,018	0,020

V4002NN – HAIMER MILL Alu Series VOLLRADIUS/BALL NOSE

Technische Daten und Produkteigenschaften/Technical data and Product characteristics



Wahlweise / Optional:

- Glattschaft DIN 6535-HA / Straight shank DIN 6535-HA
- Safe-Lock Schaft (S-λ) / Safe-Lock shank (S-λ)
- Weldonschaft ähnlich DIN 6535-HB / Weldon shank similar DIN 6535-HB



Eigenschaften Characteristics	Anwendung Application	Kühlung Coolant
DIN 6527 L		
VR	45°	Air
Z=2		
32° 34°		

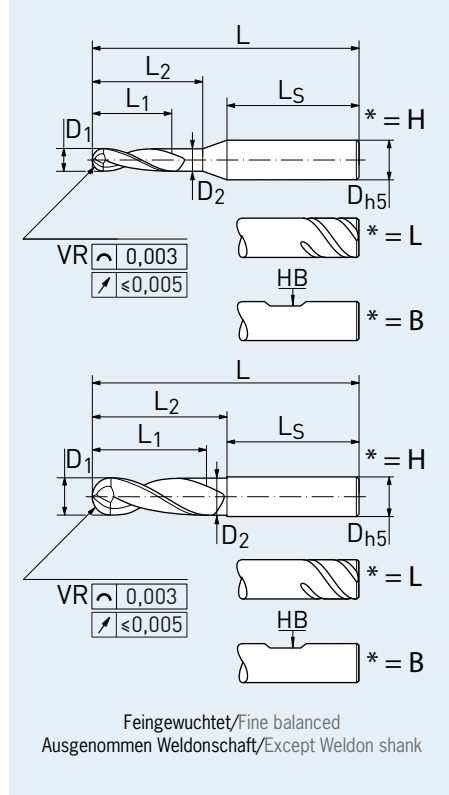

Material – Merkmale/Material – characteristics

Haupteinsatz
Main Material



- Beschichtung für abrasive Werkstoffe
- Halsabsatz für längere Eingriffstiefe
- Vollradius
- Polierte Span- und Freiflächen
- Coating for abrasive materials
- Neck for higher cutting depth
- Ball Nose
- Polished flute and relief

Artikel-Code Article-Code	Qualität Quality	D1 D1 [mm]	VR VR ± 0,005 mm	L1 max. L1 max. [mm]	L L [mm]	L2 L2 [mm]	D2 D2 [mm]	D (h5) D (h5) [mm]	LS LS [mm]	Schaft Shank	
V4002NN*0200R..	AC	2	-0,005 -0,025	0,9925	7	58	9	1,9	6	44,3	HA/S-λ/HB
V4002NN*0300R..	AC	3	-0,005 -0,025	1,4925	8	58	10	2,9	6	44,0	HA/S-λ/HB
V4002NN*0400R..	AC	4	-0,010 -0,030	1,99	11	58	15	3,8	6	40,0	HA/S-λ/HB
V4002NN*0500R..	AC	5	-0,010 -0,030	2,49	13	58	18	4,8	6	37,875	HA/S-λ/HB
V4002NN*0600R..	AC	6	-0,010 -0,030	2,99	13	58	20	5,7	6	36,5	HA/S-λ/HB
V4002NN*0800R..	AC	8	-0,010 -0,030	3,99	19	64	26	7,6	8	36,5	HA/S-λ/HB
V4002NN*1000R..	AC	10	-0,010 -0,030	4,99	22	73	30,5	9,5	10	40,5	HA/S-λ/HB
V4002NN*1200R..	AC	12	-0,010 -0,030	5,99	26	84	36,5	11,4	12	45,5	HA/S-λ/HB
V4002NN*1400R..	AC	14	-0,010 -0,030	6,99	26	84	36,5	13,3	14	45,5	HA/S-λ/HB
V4002NN*1600R..	AC	16	-0,010 -0,030	7,99	32	93	42,5	15,2	16	48,5	HA/S-λ/HB
V4002NN*1800R..	AC	18	-0,010 -0,030	8,99	32	93	42,5	17,1	18	48,5	HA/S-λ/HB
V4002NN*2000R..	AC	20	-0,010 -0,030	9,99	38	105	52	19	20	50,5	HA/S-λ/HB

* = L - Safe-Lock / H - Glattschaft / B - Weldonschaft. Bestellnummer = Artikel-Code + Qualität.
* = L - Safe-Lock / H - Straight shank / B - Weldon shank. Order No. = Article Code + Quality.

DUO-LOCK®

**Innovative Materialien erfordern innovative Zerspanungslösungen.
Advanced Materials Require Advanced Manufacturing.**

Kontinuierlich wird in vielen Industrien, wie Luft- und Raumfahrt, Energie oder Transportwesen die Entwicklung hochfester und leichter Materialien wie Titanlegierungen, Inconel und neuer Aluminiumlegierungen vorangetrieben. Diese neuen Materialien stellen an sich schon extreme Herausforderungen für die Zerspanung dar. Hinzu kommt der Wettbewerbsdruck in diesen globalen Industrien, wodurch die Suche nach fortschrittlichen Zerspanungslösungen oberste Priorität erlangt.

The continuing development of high-strength, lightweight materials such as titanium alloys, Inconel, and new aluminum alloys are eagerly sought by manufacturers in many industries, including aerospace and defense, energy, and transportation. These new materials present significant machining challenges in themselves. Add the competitive pressures in these global industries, and finding advanced manufacturing solutions becomes a top priority.

DUO-LOCK®

Die Duo-Lock Technologie trägt durch die modulare Schnittstelle für Werkzeugköpfe den steigenden Hartmetallkosten Rechnung. Duo-Lock liefert maximale Stabilität und Belastbarkeit durch ein geschütztes und einzigartiges Gewindedesign mit Doppelkonus. Das resultiert in unübertroffener Präzision und Produktivität bei einer Verbindung, die in den anspruchsvollsten Anwendungen nahezu unzerbrechlich ist.

DUO-LOCK®

The Duo-Lock technology addresses the issue of the increasing cost of carbide by delivering a modular interface for cutting tool heads. Duo-Lock provides maximum stability and load capacity through a proprietary thread design with a double cone bond. The results are unmatched precision and productivity, with a connection that is virtually unbreakable in the most demanding applications.

SAFE-LOCK®

Die Auszugsicherung Safe-Lock wird künftig auch auf modulare Duo-Lock Verlängerungen übertragen und damit Vorteile in der Bearbeitung mit langen Auskräglängen und bei extremen Fräsanwendungen sichern.

SAFE-LOCK®

The Safe-Lock anti-pullout interface will be also available with modular Duo-Lock extensions to take advantage of long reach and aggressive cuts.



Erstmals kann ein modulares Frässystem eine ähnlich hohe Leistung erzielen wie die neueste Generation von Vollhartmetallfräsern.

Die bahnbrechende Technologie des Duo-Lock Systems basiert auf der Innovationskraft zweier weltweit führender Hersteller im Zerspanungsbereich – Kennametal und HAIMER.

Duo-Lock erlaubt es, das volle Potential des Hartmetallwerkzeugs mit Produktivitätsvorteilen sowohl in der Schrupp- als auch in der Schlichtbearbeitung auszuschöpfen. Das System zeichnet sich durch hohe Belastbarkeit und Steifigkeit bei hohem Zeitspanvolumen aus. Ausgestattet mit Hochleistungs-Fräsköpfen ermöglicht Duo-Lock in üblichen Fräsanwendungen mehr als das doppelte Zeitspanvolumen.

For the first time, a modular milling system can achieve the similar high performance of the latest generation solid carbide end mill.

To deliver groundbreaking joint technology, Duo-Lock combines the innovative histories of two leaders in the world of manufacturing – Kennametal and HAIMER.

Duo-Lock maximizes a carbide tool's full potential with productivity gains in both roughing and finishing. It provides high load capacity and rigidity when machining at high metal removal rates. When combined with high-performance cutting tools, Duo-Lock provides more than double the metal removal rate in common milling applications.

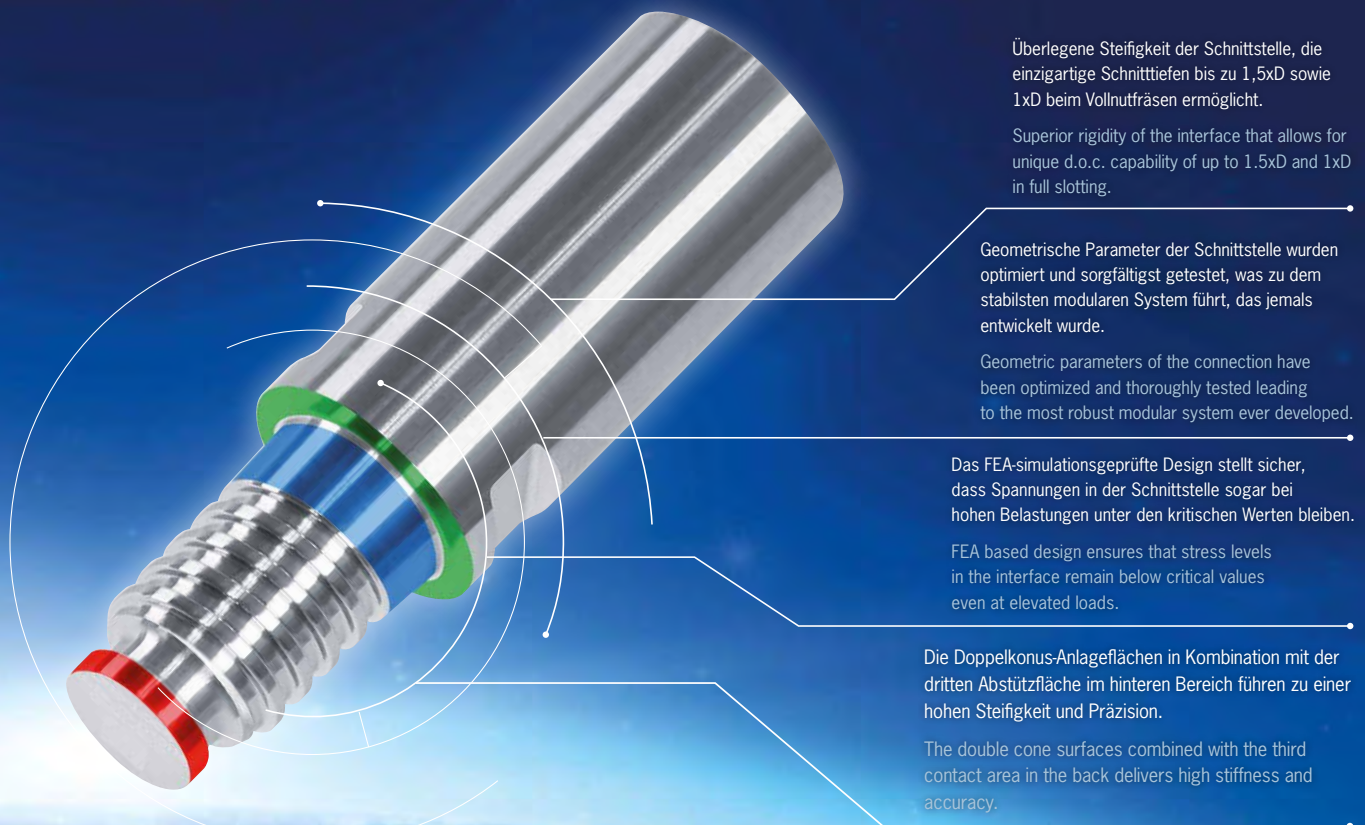

Überlegene Steifigkeit der Schnittstelle, die einzigartige Schnitttiefen bis zu 1,5xD sowie 1xD beim Vollnutfräsen ermöglicht.

Superior rigidity of the interface that allows for unique d.o.c. capability of up to 1.5xD and 1xD in full slotting.

Geometrische Parameter der Schnittstelle wurden optimiert und sorgfältig getestet, was zu dem stabilsten modularen System führt, das jemals entwickelt wurde.

Geometric parameters of the connection have been optimized and thoroughly tested leading to the most robust modular system ever developed.

Das FEA-simulationsgeprüfte Design stellt sicher, dass Spannungen in der Schnittstelle sogar bei hohen Belastungen unter den kritischen Werten bleiben.

FEA based design ensures that stress levels in the interface remain below critical values even at elevated loads.

Die Doppelkonus-Anlageflächen in Kombination mit der dritten Abstützfläche im hinteren Bereich führen zu einer hohen Steifigkeit und Präzision.

The double cone surfaces combined with the third contact area in the back delivers high stiffness and accuracy.

ÜBERSICHT DUO-LOCK® OVERVIEW DUO-LOCK®

Produkte/Products	ø D1	Seite/Page	Merkmale/Characteristics
E1002KK – HAIMER MILL MULTIFUNKTIONSFÄHRER/MULTIFUNCTION END MILL 	ø 10 – ø 20	103	  
E1014UK – HAIMER MILL VIERTELKREISFÄHRER/QUADRANT END MILL 	ø 10 – ø 20	105	 
E1016/18 – HAIMER MILL ENTGRATFÄHRER/CHAMFERING END MILL 	ø 10 – ø 20	107	  
F1004MN – HAIMER MILL Power Series 	ø 10 – ø 32	109	   
F1004MN – HAIMER MILL Power Series KÜHLUNG RADIAL/COOLING RADIAL 	ø 10 – ø 32	111	   
F1004MN – HAIMER MILL Power Series 	ø 10 – ø 32	113	   
F1004MN – HAIMER MILL Power Series KÜHLUNG RADIAL/COOLING RADIAL 	ø 10 – ø 32	115	   
F1004MN – HAIMER MILL Power Series 	ø 10 – ø 20	117	   
F1004MN – HAIMER MILL Power Series 	ø 10 – ø 20	121	   
F1105LL – HAIMER MILL Power Series SPANBRECHER/CHIP BREAKER 	ø 10 – ø 32	125	   

Anwendung/Application

Material/Material



Haupteinsatz
Main Material



auch geeignet für
also suitable for

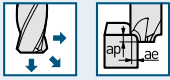

Haupteinsatz
Main Material



auch geeignet für
also suitable for



Haupteinsatz
Main Material



auch geeignet für
also suitable for

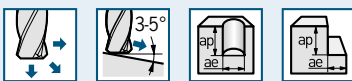

Haupteinsatz
Main Material



auch geeignet für
also suitable for

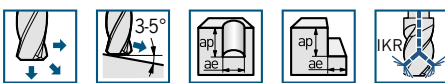

Haupteinsatz
Main Material



auch geeignet für
also suitable for

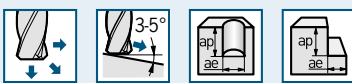

Haupteinsatz
Main Material



auch geeignet für
also suitable for

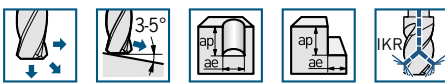

Haupteinsatz
Main Material



auch geeignet für
also suitable for

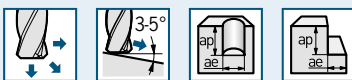

Haupteinsatz
Main Material



auch geeignet für
also suitable for

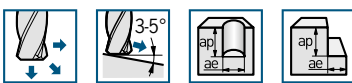

Haupteinsatz
Main Material



auch geeignet für
also suitable for



Haupteinsatz
Main Material



auch geeignet für
also suitable for



ÜBERSICHT DUO-LOCK® OVERVIEW DUO-LOCK®

Produkte/Products	ø D1	Seite/Page	Merkmale/Characteristics
F1105MN – HAIMER MILL Power Series SPANBRECHER/CHIP BREAKER 	ø 10 – ø 32	127	   
F2003MN – HAIMER MILL 	ø 2 – ø 20	129	   
F2003UK – HAIMER MILL 	ø 10 – ø 20	131	   
F2004MN – HAIMER MILL 	ø 2 – ø 32	133	   
F2004MN – HAIMER MILL 	ø 10 – ø 20	135	   
F2004UK – HAIMER MILL 	ø 10 – ø 32	139	   
F2006/08/00MN – HAIMER MILL SCHLICHTEN/FINISHING 	ø 10 – ø 20	141	   
F2006/08/00MN – HAIMER MILL SCHLICHTEN/FINISHING 	ø 10 – ø 20	143	   
F2006/08/00UK – HAIMER MILL SCHLICHTEN/FINISHING 	ø 10 – ø 20	145	   

Anwendung/Application

Material/Material



Haupteinsatz
Main Material



auch geeignet für
also suitable for

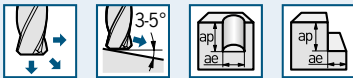

Haupteinsatz
Main Material



auch geeignet für
also suitable for

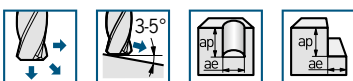

Haupteinsatz
Main Material



auch geeignet für
also suitable for

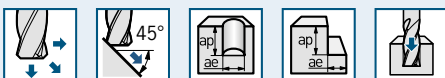

Haupteinsatz
Main Material



auch geeignet für
also suitable for

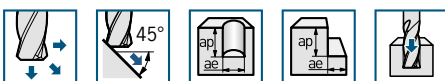

Haupteinsatz
Main Material



auch geeignet für
also suitable for

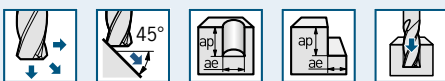

Haupteinsatz
Main Material



auch geeignet für
also suitable for



Haupteinsatz
Main Material



auch geeignet für
also suitable for



Haupteinsatz
Main Material



auch geeignet für
also suitable for



Haupteinsatz
Main Material



auch geeignet für
also suitable for



ÜBERSICHT DUO-LOCK® OVERVIEW DUO-LOCK®

Produkte/Products	ø D1	Seite/Page	Merkmale/Characteristics
F2304MN – HAIMER MILL SCHRUPPVERZÄHNUNG/ROUGHING 	ø 10 – ø 20	147	   
F2304UK – HAIMER MILL SCHRUPPVERZÄHNUNG/ROUGHING 	ø 10 – ø 20	149	   
F4002MN – HAIMER MILL Alu Series 	ø 10 – ø 20	151	   
F4002MN – HAIMER MILL Alu Series 	ø 10 – ø 20	153	   
F4003MN – HAIMER MILL Alu Series 	ø 10 – ø 20	155	   
F4003MN – HAIMER MILL Alu Series 	ø 10 – ø 20	157	   
H2004UK – HAIMER MILL HF Series HOCHVORSCHUB KZ/HIGH FEED KZ 	ø 10 – ø 20	159	   
H2006UK – HAIMER MILL HF Series HOCHVORSCHUB KZ/HIGH FEED KZ 	ø 10 – ø 20	161	   

Anwendung/Application

Material/Material

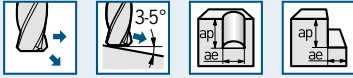

Haupteinsatz
Main Material



auch geeignet für
also suitable for

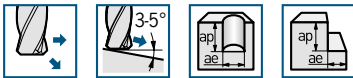

Haupteinsatz
Main Material



auch geeignet für
also suitable for

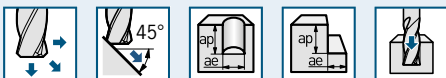

Haupteinsatz
Main Material

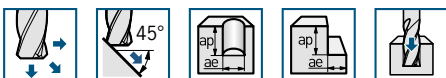

Haupteinsatz
Main Material

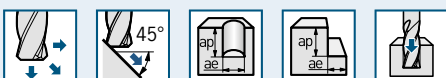

Haupteinsatz
Main Material

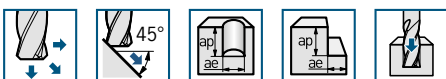

Haupteinsatz
Main Material

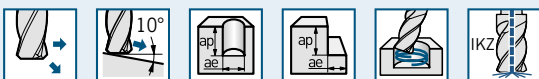

Haupteinsatz
Main Material



auch geeignet für
also suitable for

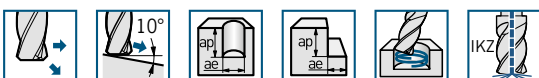

Haupteinsatz
Main Material



auch geeignet für
also suitable for



ÜBERSICHT DUO-LOCK® OVERVIEW DUO-LOCK®

Produkte/Products	ø D1	Seite/Page	Merkmale/Characteristics
V2002MN – HAIMER MILL 	ø 2 – ø 10	163	   
V2002UK – HAIMER MILL 	ø 10 – ø 20	165	   
V2002UK – HAIMER MILL KÜHLUNG RADIAL/COOLING RADIAL 	ø 10 – ø 20	167	   
V2004MN – HAIMER MILL 	ø 2 – ø 10	169	   
V2004UK – HAIMER MILL 	ø 10 – ø 20	171	   
V2004UK – HAIMER MILL KÜHLUNG RADIAL/COOLING RADIAL 	ø 10 – ø 20	173	   
V4002UK – HAIMER MILL Alu Series 	ø 10 – ø 20	175	   
V4002UK – HAIMER MILL Alu Series 	ø 10 – ø 20	177	   

Anwendung/Application

Material/Material



Haupteinsatz
Main Material



auch geeignet für
also suitable for



Haupteinsatz
Main Material



auch geeignet für
also suitable for



Haupteinsatz
Main Material



auch geeignet für
also suitable for



Haupteinsatz
Main Material



auch geeignet für
also suitable for



Haupteinsatz
Main Material



auch geeignet für
also suitable for



Haupteinsatz
Main Material



auch geeignet für
also suitable for



Haupteinsatz
Main Material

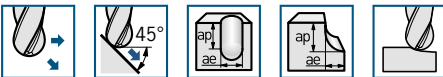

Haupteinsatz
Main Material



ERKLÄRUNG ICONS/ARTIKEL CODE/MATERIAL-LISTE DUO-LOCK® EXPLANATION ICONS/ARTICLE CODE/MATERIAL LIST DUO-LOCK®

Erklärung Icons/Explanation Icons

Eigenschaften/Characteristics

Schneidlänge Cutting length	Scharfkantig Sharp cutting edge	Eckenfase Corner chamfer	Eckenradius Corner radius	Vollradius Ball Nose	Spitze Spot	Eckradius Edge radius	
Zähnezahl 2 Teeth 2	Zähnezahl 3 Teeth 3	Zähnezahl 4 Teeth 4	Zähnezahl 5 Teeth 5	Zähnezahl 6 Teeth 6	Zähnezahl 8 Teeth 8	Zähnezahl 10 Teeth 10	Drallwinkel Helix angle

Anwendung/Application

Vorschubrichtung Feed direction	Vorschubrichtung Feed direction	Vorschubrichtung Feed direction	Rampen Ramping	Nutfräsen Slotting	Wälz-/Eckfräsen Side milling	Abrunden Rounding	Fasen Chamfering
Bohren Drilling	Kopieren 3D Milling	V-Nuten V-slotting	Konturfasen Contouring	Fasen Chamfering	Wälzen Side milling	Helikales Bohren Helical drilling	

Kühlung/Coolant

Emulsion Emulsion	Kaltluftdüse Cold air	Trockenbearbeitung Dry machining	Mindermengenschmierung Minimal lubrication	Innenkühlung zentral Central inner cooling	Innenkühlung radial Radial inner cooling

Erklärung Artikel Code/Explanation article code

DL12	F	1	0	0	2	M	N
Schnittstelle Interface	Werkzeug-Typ Tool type	Gruppe Group	Ausführung Type	Modifikation Modification	Zähnezahl No. of teeth	Schneidlänge Length of cut	Gesamtlänge Overall length
DL10	F- Zylinderfräser Cylindrical end mill	1- Universal	0- Glatte Schneide Plain cutter	0- Halsfrei- setzung With neck	2- Z2	L- 2.6-3.5xD	N- 2xD
DL12		2- Stahl			3- Z3	M- 1.5xD	L- 3.5xD
DL16	V- Vollradiusfräser Ball nose end mill	< 52HRC	1- Spanbrecher Chip breaker	1- Keine Halsfrei- setzung No Neck	4- Z4	K- 1.25xD	K- 1.25xD
DL20					5- Z5		
DL25	E- Entgratfräser Chamfering end mill	4- Alu	3- Schrupp Rough		6- Z6		
DL32	H- HighFeed-Fräser HighFeed end mill	6- Titan/ Inconel			8- Z8		
					0- Z10		

Material-Liste/Material list

HAIMER Werkstoff Gruppen HAIMER Material groups	Beispiel Werkstoffe Example material	Werkstoff Information Material information			
		DIN DIN	Werkstoffnr. Material no.	Zugfestigkeit Tensile strength	Inhalt/Härte Content/Hardness
P1	Allg. Bau-, Einsatzstähle General construction steels	S235JR (RST37-2), E295 (St 50-2), C45	1.0038, 1.0050, 1.0503	≤ 800 N/mm ²	bis 25 HRC up to 25 HRC
P2	Werkzeug/Vergütungsstähle Heat treated steels	X38CrMoV5-3, X153CrMoV12, X100CrMoV5, 42CrMo4	1.2367, 1.2379, 1.2363, 1.7225	> 800 N/mm ²	bis 45 HRC up to 45 HRC
M1	Rostfreie Stähle Stainless steels	X8CrNiS18-9, X5CrNi18-10, X46Cr13	1.4305, 1.4301, 1.4034	≤ 650 N/mm ²	
M2	Rostfreie Stähle Stainless steels	X6CrNiMoTi17-12-2, X2CrNiMo17-12-2, X4CrNiMo16-5-1	1.4571, 1.4404, 1.4418	> 650 N/mm ²	
K1	Gusseisen Cast iron	EN-GJL200 (GG20), EN-GJLZ (GG40), EN-GJS-400-15 (GGG40)	0.6020, 0.6040, 0.7040	≤ 450 N/mm ²	
K2	Gusseisen Cast iron	EN-GJS-600-3 (GGG60), EN-GJS-700-2 (GGG70)	0.7060, 0.7070	> 450 N/mm ²	
S1	Titan & Titanlegierungen Titanium & titanium alloys	TiAl6V4	3.7165		
S2	Warmfeste Legierungen High Temp alloys	Inconel; NIMONIC		800 – 1700 N/mm ²	
N1	Alu-Knetlegierungen Wrought aluminum alloys	AlMg1	3.3315		Si < 9%
N2	Alu-Gusslegierungen Aluminum cast alloys	G-ALsi12	3.2581		Si > 9%
H1	Gehärtete Stähle Hardened steels				45 – 55 HRC
H2	Gehärtete Stähle Hardened steels				> 55 HRC

1000	R	1.00	A	A	0001	KR
Durchmesser Diameter	Schneidkantenübergang Cutting edge transition	Größe Übergang Size transition	Material Material	Beschichtung Coating	Sondernummer Special number	Kühlung Cooling
1200- Metrisch Metric 1/2Z- Inch Inch	S- Scharfkantig Sharp cutting edge C- Fase Chamfer R- Radius Radius W- Fasenwinkel Chamfer angle	1.00- Metrisch Metric .03- Inch Inch 90- Fasenwinkel Chamfer angle 60- Fasenwinkel Chamfer angle 120- Fasenwinkel Chamfer angle	A- HF10 h5 D- HF10 h6	A- HAIMER-UNI C- HAIMER-ALU P- HAIMER-P - keine none	0000 - 9999	KR- Kühlung radial Cooling radial KZ- Kühlung zentral Cooling central KS- Kühlung sonder Cooling special

E1002KK – DUO-LOCK® HAIMER MILL MULTIFUNKTIONSFRÄSER/MULTIFUNCTION END MILL

Schnittdaten/Cutting data

HAIMER Werkstoff Gruppen HAIMER Material groups	Beispiel Werkstoffe Example material	Werkstoffnr. Material no.	Werkstoff Information Material information		Schruppen Vc (m/min) Roughing Vc (m/min)	Schlichten Vc (m/min) Finishing Vc (m/min)	
			Zugfestigkeit Tensile strength	Inhalt/Härte Content/ Hardness			
P1	Allg. Bau-, Einsatzstähle General construction steels	S235JR (RST37-2), E295 (St 50-2), C45	1.0038, 1.0050, 1.0503	≤ 800 N/mm ²	bis 25 HRC up to 25 HRC	160 – 220	220 – 280
P2	Werkzeug-/Vergütungsstähle Heat treated steels	X38CrMoV5-3, X153CrMoV12, X100CrMoV5, 42CrMo4	1.2367, 1.2379, 1.2363, 1.7225	> 800 N/mm ²	bis 45 HRC up to 45 HRC	120 – 160	160 – 200
M1	Rostfreie Stähle Stainless steels	X8CrNiS18-9, X5CrNi18-10, X46Cr13	1.4305, 1.4301, 1.4034	≤ 650 N/mm ²		80 – 120	120 – 160
M2	Rostfreie Stähle Stainless steels	X6CrNiMoTi17-12-2, X2CrNiMo17-12-2, X4CrNiMo16-5-1	1.4571, 1.4404, 1.4418	> 650 N/mm ²		60 – 90	90 – 120
K1	Gusseisen Cast iron	EN-GJL200 (GG20), EN-GJLZ (GG40), EN-GJS-400-15 (GGG40)	0.6020, 0.6040, 0.7040	≤ 450 N/mm ²		120 – 180	180 – 240
K2	Gusseisen Cast iron	EN-GJS-600-3 (GGG60), EN-GJS-700-2 (GGG70)	0.7060, 0.7070	> 450 N/mm ²		80 – 160	160 – 220
S1	Titan & Titanlegierungen Titanium & titanium alloys	TiAl6V4	3.7165			40 – 80	40 – 80
S2	Wärmefeste Legierungen High Temp alloys	Inconel; NIMONIC		800 – 1700 N/mm ²		30 – 40	30 – 40
N1	Alu-Knetlegierungen Wrought aluminum alloys	AlMg1	3.3315		Si < 9%	500 – 900	500 – 900
N2	Alu-Gusslegierungen Aluminum cast alloys	G-Alsi12	3.2581		Si > 9%	120 – 350	120 – 350
H1	Gehärtete Stähle Hardened steels				45 – 55 HRC	40 – 60	60 – 80

Schnittdaten dienen als Richtwerte und müssen dem Bearbeitungsumfeld angepasst werden.
Cutting data are reference values and need to be adjusted according to the application area.

Vorschubtable f_z (mm/Zahn) abhängig von D1 und Schnittbreite a_e /Feed per tooth (mm/tooth) in relation with D1 and cutting width a_e

	ø 10	ø 12	ø 16	ø 20
f _z	0,03 – 0,09	0,03 – 0,10	0,04 – 0,12	0,05 – 0,13

Schnittdaten Basis zylindrische Verlängerung kurz, Schnittdaten bei längeren Auskragungen anpassen.
Cutting data is based on cylindrical extensions short, cutting data for long overhang need to be adjusted.

E1002KK – DUO-LOCK® HAIMER MILL MULTIFUNKTIONSFRÄSER/MULTIFUNCTION END MILL

Technische Daten und Produkteigenschaften/Technical data and Product characteristics



Eigenschaften Characteristics	Anwendung Application	Kühlung Coolant
W		
Z=2		Air
20°		MMS

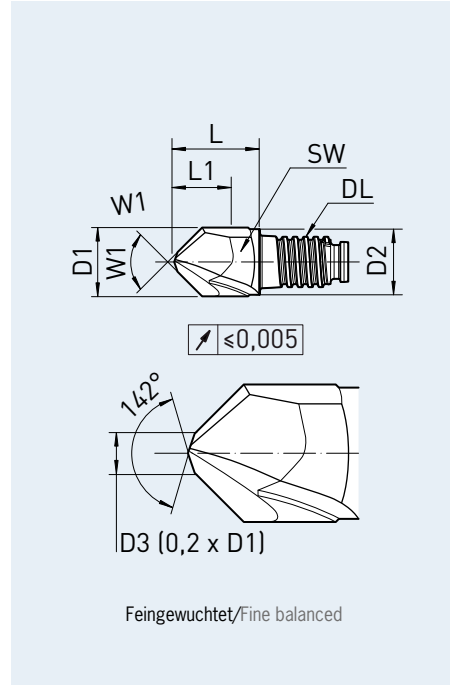

Material – Merkmale/Material – characteristics

Haupteinsatz
Main Material



auch geeignet für
also suitable for



- Konuswinkel 60/90/120/142°
 - Zentrierspitze
 - Multifunktionales Werkzeug
 - Umfangsschneiden
 - Beste Längenwiederholgenauigkeit
- Cone angle 60/90/120/142°
 - Center spot
 - Multifunctional tool
 - Circumference cutter
 - Best length repeatability

Artikel-Code Article-Code	Qualität Quality	Duo-Lock Größe Size	Z Z	D1 (f9) D1 (f9) [mm]	Fasenfräser Chamfer	W1 W1	L1 max. L1 max. [mm]	L L [mm]	D2 D2 [mm]	SW AF [mm]	Drehmoment Torque [N/m]
DL10E1002KK1000W60..	DA	DL10	2	10,00	W	60°	10	12,5	9,6	SW8	20
DL10E1002KK1000W90..	DA	DL10	2	10,00	W	90°	10	12,5	9,6	SW8	20
DL10E1002KK1000W120..	DA	DL10	2	10,00	W	120°	10	12,5	9,6	SW8	20
DL10E1002KK1000W142..	DA	DL10	2	10,00	W	142°	10	12,5	9,6	SW8	20
DL12E1002KK1200W60..	DA	DL12	2	12,00	W	60°	12	15	11,5	SW9,5	30
DL12E1002KK1200W90..	DA	DL12	2	12,00	W	90°	12	15	11,5	SW9,5	30
DL12E1002KK1200W120..	DA	DL12	2	12,00	W	120°	12	15	11,5	SW9,5	30
DL12E1002KK1200W142..	DA	DL12	2	12,00	W	142°	12	15	11,5	SW9,5	30
DL16E1002KK1600W60..	DA	DL16	2	16,00	W	60°	16	20	15,5	SW13	60
DL16E1002KK1600W90..	DA	DL16	2	16,00	W	90°	16	20	15,5	SW13	60
DL16E1002KK1600W120..	DA	DL16	2	16,00	W	120°	16	20	15,5	SW13	60
DL16E1002KK1600W142..	DA	DL16	2	16,00	W	142°	16	20	15,5	SW13	60
DL20E1002KK2000W60..	DA	DL20	2	20,00	W	60°	20	25	19,3	SW16	80
DL20E1002KK2000W90..	DA	DL20	2	20,00	W	90°	20	25	19,3	SW16	80
DL20E1002KK2000W120..	DA	DL20	2	20,00	W	120°	20	25	19,3	SW16	80
DL20E1002KK2000W142..	DA	DL20	2	20,00	W	142°	20	25	19,3	SW16	80

Bestellnummer = Artikel-Code + Qualität.
Order No. = Article Code + Quality.

E1014UK – DUO-LOCK® HAIMER MILL VIERTELKREISFRÄSER/QUADRANT END MILL

Schnittdaten/Cutting data

HAIMER Werkstoff Gruppen HAIMER Material groups	Beispiel Werkstoffe Example material	Werkstoffnr. Material no.	Werkstoff Information Material information		Schruppen Vc (m/min) Roughing Vc (m/min)	Schlichten Vc (m/min) Finishing Vc (m/min)	
			Zugfestigkeit Tensile strength	Inhalt/Härte Content/ Hardness			
P1	Allg. Bau-, Einsatzstähle General construction steels	S235JR (RST37-2), E295 (St 50-2), C45	1.0038, 1.0050, 1.0503	≤ 800 N/mm ²	bis 25 HRC up to 25 HRC	160 – 220	220 – 280
P2	Werkzeug-/Vergütungsstähle Heat treated steels	X38CrMoV5-3, X153CrMoV12, X100CrMoV5, 42CrMo4	1.2367, 1.2379, 1.2363, 1.7225	> 800 N/mm ²	bis 45 HRC up to 45 HRC	120 – 160	160 – 200
M1	Rostfreie Stähle Stainless steels	X8CrNiS18-9, X5CrNi18-10, X46Cr13	1.4305, 1.4301, 1.4034	≤ 650 N/mm ²		80 – 120	120 – 160
M2	Rostfreie Stähle Stainless steels	X6CrNiMoTi17-12-2, X2CrNiMo17-12-2, X4CrNiMo16-5-1	1.4571, 1.4404, 1.4418	> 650 N/mm ²		60 – 90	90 – 120
K1	Gusseisen Cast iron	EN-GJL200 (GG20), EN-GJLZ (GG40), EN-GJS-400-15 (GGG40)	0.6020, 0.6040, 0.7040	≤ 450 N/mm ²		120 – 180	180 – 240
K2	Gusseisen Cast iron	EN-GJS-600-3 (GGG60), EN-GJS-700-2 (GGG70)	0.7060, 0.7070	> 450 N/mm ²		80 – 160	160 – 220
S1	Titan & Titanlegierungen Titanium & titanium alloys	TiAl6V4	3.7165			40 – 80	40 – 80
S2	Wärmefeste Legierungen High Temp alloys	Inconel; NIMONIC		800 – 1700 N/mm ²		30 – 40	30 – 40
N1	Alu-Knetlegierungen Wrought aluminum alloys	AlMg1	3.3315		Si < 9%	500 – 900	500 – 900
N2	Alu-Gusslegierungen Aluminum cast alloys	G-Alsi12	3.2581		Si > 9%	120 – 350	120 – 350
H1	Gehärtete Stähle Hardened steels				45 – 55 HRC	40 – 60	60 – 80

Schnittdaten dienen als Richtwerte und müssen dem Bearbeitungsumfeld angepasst werden.
 Cutting data are reference values and need to be adjusted according to the application area.

Vorschubtable f_z (mm/Zahn) abhängig von D1 und Schnittbreite ae / Feed per tooth (mm/tooth) in relation with D1 and cutting width ae

	∅ 10	∅ 12	∅ 16	∅ 20
f _z	0,03 – 0,09	0,03 – 0,10	0,04 – 0,12	0,05 – 0,13

Schnittdaten Basis zylindrische Verlängerung kurz, Schnittdaten bei längeren Auskragungen anpassen.
 Cutting data is based on cylindrical extensions short, cutting data for long overhang need to be adjusted.

E1014UK – DUO-LOCK® HAIMER MILL VIERTELKREISFRÄSER/QUADRANT END MILL

Technische Daten und Produkteigenschaften/Technical data and Product characteristics



Eigenschaften Characteristics



Anwendung Application

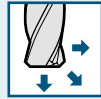

Kühlung Coolant

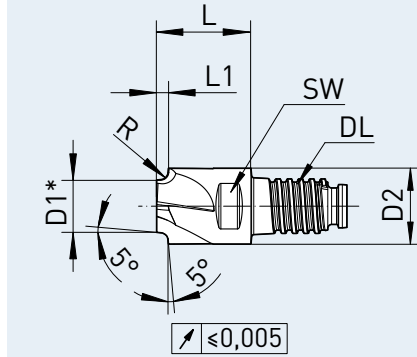
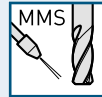

Feingewuchtet/Fine balanced
* nicht zentrumschneidender Durchmesser
* diameter not center cutting

Material – Merkmale/Material – characteristics

Haupteinsatz
Main Material



auch geeignet für
also suitable for



- Zur Konturverrundung
- 5° tangentielle Freisetzung
- Positiver Spanwinkel ohne Profilverzerrung
- Beste Längenwiederholgenauigkeit

- For contour rounding
- 5° tangential release
- Positive rake angle without profile displacement
- Best length repeatability

Artikel-Code Article-Code	Qualität Quality	Duo-Lock Größe Size	D1 (h9) D1 (h9) [mm]	Schneidecke Cutting edge	Radius Radius [mm]	L1 max. L1 max. [mm]	L L [mm]	D2 D2 [mm]	SW AF [mm]	Drehmoment Torque [N/m]
DL10E1014UK1000R1.00..	DA	DL10	7	R	1,00	1,50	12.5	10	SW8	20
DL10E1014UK1000R1.50..	DA	DL10	6	R	1,50	2,00	12.5	10	SW8	20
DL10E1014UK1000R2.00..	DA	DL10	5	R	2,00	2,50	12.5	10	SW8	20
DL12E1014UK1200R2.50..	DA	DL12	6	R	2,50	3,00	15.0	12	SW9,5	30
DL12E1014UK1200R3.00..	DA	DL12	5	R	3,00	3,50	15.0	12	SW9,5	30
DL16E1014UK1600R3.50..	DA	DL16	8	R	3,50	4,00	20.0	16	SW13	60
DL16E1014UK1600R4.00..	DA	DL16	7	R	4,00	4,50	20.0	16	SW13	60
DL16E1014UK1600R4.50..	DA	DL16	6	R	4,50	5,00	20.0	16	SW13	60
DL20E1014UK2000R5.00..	DA	DL20	8	R	5,00	6,00	25.0	20	SW16	80
DL20E1014UK2000R6.00..	DA	DL20	6	R	6,00	7,00	25.0	20	SW16	80

Bestellnummer = Artikel-Code + Qualität.
Order No. = Article Code + Quality.

E1016UK/E1018UK – DUO-ΛOCK® HAIMER MILL ENTGRATFRÄSER/CHAMFERING END MILL

Schnittdaten/Cutting data

HAIMER Werkstoff Gruppen HAIMER Material groups	Beispiel Werkstoffe Example material	Werkstoffnr. Material no.	Werkstoff Information Material information		Schruppen Vc (m/min) Roughing Vc (m/min)	Schlichten Vc (m/min) Finishing Vc (m/min)	
			Zugfestigkeit Tensile strength	Inhalt/Härte Content/ Hardness			
P1	Allg. Bau-, Einsatzstähle General construction steels	S235JR (RST37-2), E295 (St 50-2), C45	1.0038, 1.0050, 1.0503	≤ 800 N/mm ²	bis 25 HRC up to 25 HRC	160 – 220	220 – 280
P2	Werkzeug-/Vergütungsstähle Heat treated steels	X38CrMoV5-3, X153CrMoV12, X100CrMoV5, 42CrMo4	1.2367, 1.2379, 1.2363, 1.7225	> 800 N/mm ²	bis 45 HRC up to 45 HRC	120 – 160	160 – 200
M1	Rostfreie Stähle Stainless steels	X8CrNiS18-9, X5CrNi18-10, X46Cr13	1.4305, 1.4301, 1.4034	≤ 650 N/mm ²		80 – 120	120 – 160
M2	Rostfreie Stähle Stainless steels	X6CrNiMoTi17-12-2, X2CrNiMo17-12-2, X4CrNiMo16-5-1	1.4571, 1.4404, 1.4418	> 650 N/mm ²		60 – 90	90 – 120
K1	Gusseisen Cast iron	EN-GJL200 (GG20), EN-GJLZ (GG40), EN-GJS-400-15 (GGG40)	0.6020, 0.6040, 0.7040	≤ 450 N/mm ²		120 – 180	180 – 240
K2	Gusseisen Cast iron	EN-GJS-600-3 (GGG60), EN-GJS-700-2 (GGG70)	0.7060, 0.7070	> 450 N/mm ²		80 – 160	160 – 220
S1	Titan & Titanlegierungen Titanium & titanium alloys	TiAl6V4	3.7165			40 – 80	40 – 80
S2	Warmfeste Legierungen High Temp alloys	Inconel; NIMONIC		800 – 1700 N/mm ²		30 – 40	30 – 40
N1	Alu-Knetlegierungen Wrought aluminum alloys	AlMg1	3.3315		Si < 9%	500 – 900	500 – 900
N2	Alu-Gusslegierungen Aluminum cast alloys	G-Alsi12	3.2581		Si > 9%	120 – 350	120 – 350
H1	Gehärtete Stähle Hardened steels				45 – 55 HRC	40 – 60	60 – 80

Schnittdaten dienen als Richtwerte und müssen dem Bearbeitungsumfeld angepasst werden.
Cutting data are reference values and need to be adjusted according to the application area.

Vorschubtable f_z (mm/Zahn) abhängig von D1 und Schnittbreite ae / Feed per tooth (mm/tooth) in relation with D1 and cutting width ae

	∅ 10	∅ 12	∅ 16	∅ 20
f _z	0,03 – 0,09	0,03 – 0,10	0,04 – 0,12	0,05 – 0,13

Schnittdaten Basis zylindrische Verlängerung kurz, Schnittdaten bei längeren Auskragungen anpassen.
Cutting data is based on cylindrical extensions short, cutting data for long overhang need to be adjusted.

E1016UK/E1018UK – DUO-LOCK® HAIMER MILL ENTGRATFRÄSER/CHAMFERING END MILL

Technische Daten und Produkteigenschaften/Technical data and Product characteristics



Eigenschaften Characteristics	Anwendung Application	Kühlung Coolant
W		
Z=6		Air
Z=8		

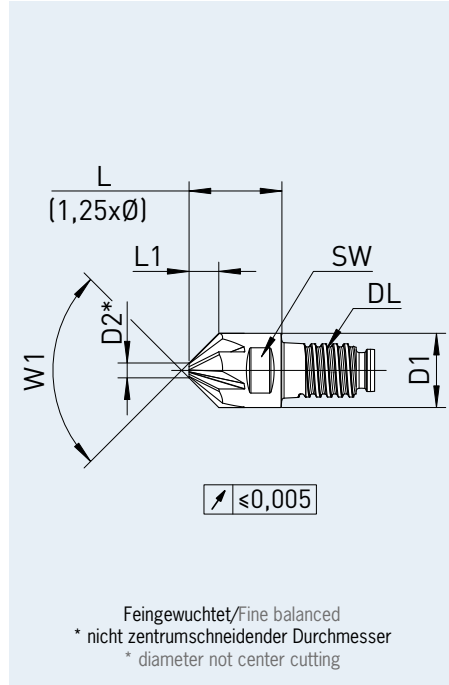

Material – Merkmale/Material – characteristics

Haupteinsatz
Main Material



auch geeignet für
also suitable for



- Konuswinkel 60/90/120°
- Spitze plan geschliffen
- Multifunktionales Werkzeug
- Beste Längenwiederholgenauigkeit
- Gerade genutet

- Cone angle 60/90/120°
- Honed tip plan
- Mult functional tool
- Best length repeatability
- Straight fluted

Artikel-Code Article-Code	Qualität Quality	Duo-Lock Größe Size	Z	D1 (h6) D1 (h6) [mm]	Fasenfräser Chamfer	W1	L1 max. L1 max. [mm]	L L [mm]	D2 D2 [mm]	SW AF [mm]	Drehmoment Torque [N/m]
DL10E1016UK1000W60..	DA	DL10	6	10,00	W	60°	6,9	12,5	2,0	SW8	20
DL10E1016UK1000W90..	DA	DL10	6	10,00	W	90°	4	12,5	2,0	SW8	20
DL10E1016UK1000W120..	DA	DL10	6	10,00	W	120°	2,3	12,5	2,0	SW8	20
DL12E1016UK1200W60..	DA	DL12	6	12,00	W	60°	8,3	15	2,4	SW9,5	30
DL12E1016UK1200W90..	DA	DL12	6	12,00	W	90°	4,8	15	2,4	SW9,5	30
DL12E1016UK1200W120..	DA	DL12	6	12,00	W	120°	2,7	15	2,4	SW9,5	30
DL16E1018UK1600W60..	DA	DL16	8	16,00	W	60°	11	20	3,2	SW13	60
DL16E1018UK1600W90..	DA	DL16	8	16,00	W	90°	6,4	20	3,2	SW13	60
DL16E1018UK1600W120..	DA	DL16	8	16,00	W	120°	3,6	20	3,2	SW13	60
DL20E1018UK2000W60..	DA	DL20	8	20,00	W	60°	13,9	25	4	SW16	80
DL20E1018UK2000W90..	DA	DL20	8	20,00	W	90°	8	25	4	SW16	80
DL20E1018UK2000W120..	DA	DL20	8	20,00	W	120°	4,6	25	4	SW16	80

Bestellnummer = Artikel-Code + Qualität.
Order No. = Article Code + Quality.

F1004MN – DUO-LOCK® HAIMER MILL Power Series FASE/CHAMFER

Schnittdaten/Cutting data

HAIMER Werkstoff Gruppen HAIMER Material groups	Beispiel Werkstoffe Example material	DIN DIN	Werkstoffnr. Material no.	Werkstoff Information Material information		Schnittbreite/Cutting width		
				Zugfestigkeit Tensile strength	Inhalt/Härte Content/ Hardness	Schnittgeschwindigkeit Vc (m/min) Cutting speed Vc (m/min)		
P1	Allg. Bau-, Einsatzstähle General construction steels	S235JR (RST37-2), E295 (St 50-2), C45	1.0038, 1.0050, 1.0503	≤ 800 N/mm ²	bis 25 HRC up to 25 HRC	20	30	40
P2	Werkzeug/Vergütungsstähle Heat treated steels	X38CrMoV5-3, X153CrMoV12, X100CrMoV5, 42CrMo4	1.2367, 1.2379, 1.2363, 1.7225	> 800 N/mm ²	bis 45 HRC up to 45 HRC	20	30	40
M1	Rostfreie Stähle Stainless steels	X8CrNiS18-9, X5CrNi18-10, X46Cr13	1.4305, 1.4301, 1.4034	≤ 650 N/mm ²		10 – 20	10 – 20	10 – 20
M2	Rostfreie Stähle Stainless steels	X6CrNiMoTi17-12-2, X2CrNiMo17-12-2, X4CrNiMo16-5-1	1.4571, 1.4404, 1.4418	> 650 N/mm ²		10 – 20	10 – 20	10 – 20
K1	Gusseisen Cast iron	EN-GJL200 (GG20), EN-GJLZ (GG40), EN- GJS-400-15 (GGG40)	0.6020, 0.6040, 0.7040	≤ 450 N/mm ²		20 – 30	20 – 30	20 – 30
K2	Gusseisen Cast iron	EN-GJS-600-3 (GGG60), EN-GJS-700-2 (GGG70)	0.7060, 0.7070	> 450 N/mm ²		20 – 30	20 – 30	20 – 30
S1	Titan & Titanlegierungen Titanium & titanium alloys	TiAl6V4	3.7165			10	10	20
S2	Warmfeste Legierungen High Temp alloys	Inconel; NIMONIC		800 – 1700 N/mm ²		10	10	20
N1	Alu-Knetlegierungen Wrought aluminum alloys	AlMg1	3.3315		Si < 9%	300 – 400	300 – 400	400 – 500
N2	Alu-Gusslegierungen Aluminum cast alloys	G-Alsi12	3.2581		Si > 9%	300 – 400	300 – 400	400 – 500

Schnittdaten dienen als Richtwerte und müssen dem Bearbeitungsumfeld angepasst werden.
Cutting data are reference values and need to be adjusted according to the application area.

Vorschubtablette fz (mm/Zahn) abhängig von D1 und Schnittbreite ae / Feed per tooth (mm/tooth) in relation with D1 and cutting width ae				
	ø 10	ø 12	ø 16	ø 20
fz	0,03 – 0,09	0,03 – 0,10	0,04 – 0,12	0,05 – 0,13

Schnittdaten Basis zylindrische Verlängerung kurz, Schnittdaten bei längeren Auskrägungen anpassen.
Cutting data is based on cylindrical extensions short, cutting data for long overhang need to be adjusted.

F1004MN – DUO-LOCK® HAIMER MILL Power Series FASE/CHAMFER

Technische Daten und Produkteigenschaften/Technical data and Product characteristics



Eigenschaften Characteristics	Anwendung Application	Kühlung Coolant

Feingewuchtet/Fine balanced

Material – Merkmale/Material – characteristics

Haupteinsatz
Main Material



auch geeignet für
also suitable for



- Halsabsatz für längere Eingriffstiefe
 - Zentrumschneide
 - Ungleiche Schneidenteilung
 - Beste Längenwiederholgenauigkeit
 - Polierte Span- und Freiflächen
- Neck for higher cutting depth
 - Center cutting
 - Unequal cutting edge
 - Best length repeatability
 - Polished flute and relief

Artikel-Code Article-Code	Qualität Quality	Duo-Lock Größe Size	D1 (f9) D1 (f9) [mm]	Schneidecke Cutting edge	Größe Size [mm]	L1 max. L1 max. [mm]	L L [mm]	D2 D2 [mm]	SW AF [mm]	Drehmoment Torque [N/m]
DL10F1004MN1000C..	D-	DL10	10,00	C	0,20	15	20	9,6	SW8	20
DL12F1004MN1200C..	D-	DL12	12,00	C	0,24	18	24	11,5	SW9,5	30
DL16F1004MN1600C..	D-	DL16	16,00	C	0,32	24	32	15,5	SW13	60
DL20F1004MN2000C..	D-	DL20	20,00	C	0,40	30	40	19,3	SW16	80
DL25F1004MN2500C..	D-	DL25	25,00	C	0,50	37,5	50	24,0	SW21	100
DL32F1004MN3200C..	D-	DL32	32,00	C	0,64	48	64	31,0	SW28	130

Bestellnummer = Artikel-Code + Qualität.
Order No. = Article Code + Quality.

F1004MN – DUO-LOCK® HAIMER MILL Power Series FASE KÜHLUNG RADIAL/CHAMFER COOLING RADIAL

Schnittdaten/Cutting data

HAIMER Werkstoff Gruppen HAIMER Material groups	Beispiel Werkstoffe Example material	DIN DIN	Werkstoffnr. Material no.	Werkstoff Information Material information		Schnittbreite/Cutting width		
				Zugfestigkeit Tensile strength	Inhalt/Härte Content/ Hardness	Schnittgeschwindigkeit Vc (m/min) Cutting speed Vc (m/min)		
P1	Allg. Bau-, Einsatzstähle General construction steels	S235JR (RST37-2), E295 (St 50-2), C45	1.0038, 1.0050, 1.0503	≤ 800 N/mm ²	bis 25 HRC up to 25 HRC	20	30	40
P2	Werkzeug/Vergütungsstähle Heat treated steels	X38CrMoV5-3, X153CrMoV12, X100CrMoV5, 42CrMo4	1.2367, 1.2379, 1.2363, 1.7225	> 800 N/mm ²	bis 45 HRC up to 45 HRC	20	30	40
M1	Rostfreie Stähle Stainless steels	X8CrNiS18-9, X5CrNi18-10, X46Cr13	1.4305, 1.4301, 1.4034	≤ 650 N/mm ²		10 – 20	10 – 20	10 – 20
M2	Rostfreie Stähle Stainless steels	X6CrNiMoTi17-12-2, X2CrNiMo17-12-2, X4CrNiMo16-5-1	1.4571, 1.4404, 1.4418	> 650 N/mm ²		10 – 20	10 – 20	10 – 20
K1	Gusseisen Cast iron	EN-GJL200 (GG20), EN-GJLZ (GG40), EN- GJS-400-15 (GGG40)	0.6020, 0.6040, 0.7040	≤ 450 N/mm ²		20 – 30	20 – 30	20 – 30
K2	Gusseisen Cast iron	EN-GJS-600-3 (GGG60), EN-GJS-700-2 (GGG70)	0.7060, 0.7070	> 450 N/mm ²		20 – 30	20 – 30	20 – 30
S1	Titan & Titanlegierungen Titanium & titanium alloys	TiAl6V4	3.7165			10	10	20
S2	Warmfeste Legierungen High Temp alloys	Inconel; NIMONIC		800 – 1700 N/mm ²		10	10	20
N1	Alu-Knetlegierungen Wrought aluminum alloys	AlMg1	3.3315		Si < 9%	300 – 400	300 – 400	400 – 500
N2	Alu-Gusslegierungen Aluminum cast alloys	G-Alsi12	3.2581		Si > 9%	300 – 400	300 – 400	400 – 500

Schnittdaten dienen als Richtwerte und müssen dem Bearbeitungsumfeld angepasst werden.
Cutting data are reference values and need to be adjusted according to the application area.

Vorschubtablette fz (mm/Zahn) abhängig von D1 und Schnittbreite ae /Feed per tooth (mm/tooth) in relation with D1 and cutting width ae				
	ø 10	ø 12	ø 16	ø 20
fz	0,03 – 0,09	0,03 – 0,10	0,04 – 0,12	0,05 – 0,13

Schnittdaten Basis zylindrische Verlängerung kurz, Schnittdaten bei längeren Auskrägungen anpassen.
Cutting data is based on cylindrical extensions short, cutting data for long overhang need to be adjusted.

F1004MN – DUO-LOCK® HAIMER MILL Power Series FASE KÜHLUNG RADIAL/CHAMFER COOLING RADIAL

Technische Daten und Produkteigenschaften/Technical data and Product characteristics



Eigenschaften Characteristics	Anwendung Application	Kühlung Coolant

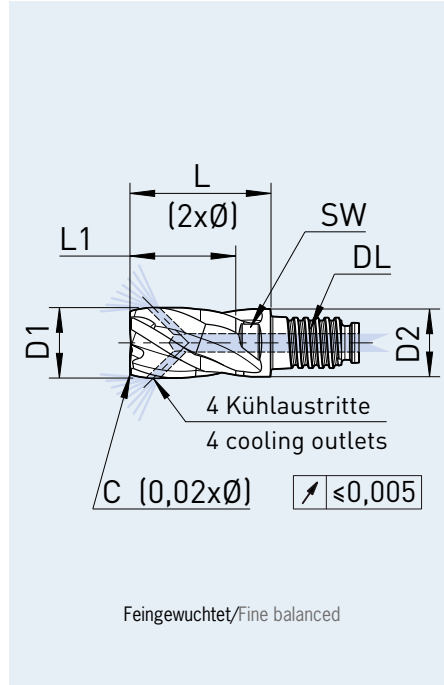

Material – Merkmale/Material – characteristics

Hauptmaterial
Main Material



auch geeignet für
also suitable for



- Innenkühlung radial
- Halsabsatz für längere Eingriffstiefe
- Zentrumschneide
- Ungleiche Schneidenteilung
- Beste Längenwiederholgenauigkeit
- Polierte Span- und Freiflächen



- Inner cooling radial
- Neck for higher cutting depth
- Center cutting
- Unequal cutting edge
- Best length repeatability
- Polished flute and relief

Artikel-Code Article-Code	Qualität Quality	Kühlung Cooling	Duo-Lock Größe Size	D1 (f9) D1 (f9) [mm]	Schneidecke Cutting edge	Größe Size [mm]	L1 max. L1 max. [mm]	L L [mm]	D2 D2 [mm]	SW AF [mm]	Drehmoment Torque [N/m]
DL10F1004MN1000C..	D-	KR	DL10	10,00	C	0,20	15	20	9,6	SW8	20
DL12F1004MN1200C..	D-	KR	DL12	12,00	C	0,24	18	24	11,5	SW9,5	30
DL16F1004MN1600C..	D-	KR	DL16	16,00	C	0,32	24	32	15,5	SW13	60
DL20F1004MN2000C..	D-	KR	DL20	20,00	C	0,40	30	40	19,3	SW16	80
DL25F1004MN2500C..	D-	KR	DL25	25,00	C	0,50	37,5	50	24,0	SW21	100
DL32F1004MN3200C..	D-	KR	DL32	32,00	C	0,64	48	64	31,0	SW28	130

Bestellnummer = Artikel-Code + Qualität + Kühlung.
Order No. = Article Code + Quality + Cooling.

F1004MN – DUO-LOCK® HAIMER MILL Power Series FASE/CHAMFER

Schnittdaten/Cutting data

HAIMER Werkstoff Gruppen HAIMER Material groups	Beispiel Werkstoffe Example material	Werkstoffnr. Material no.	Werkstoff Information Material information		Schnittbreite/Cutting width			
			Zugfestigkeit Tensile strength	Inhalt/Härte Content/ Hardness				
					Schnittgeschwindigkeit Vc (m/min) Cutting speed Vc (m/min)			
P1	Allg. Bau-, Einsatzstähle General construction steels	S235JR (RST37-2), E295 (St 50-2), C45	1.0038, 1.0050, 1.0503	≤ 800 N/mm ²	bis 25 HRC up to 25 HRC	170 – 200	210 – 240	250 – 270
P2	Werkzeug/Vergütungsstähle Heat treated steels	X38CrMoV5-3, X153CrMoV12, X100CrMoV5, 42CrMo4	1.2367, 1.2379, 1.2363, 1.7225	> 800 N/mm ²	bis 45 HRC up to 45 HRC	90 – 110	110 – 130	130 – 150
M1	Rostfreie Stähle Stainless steels	X8CrNiS18-9, X5CrNi18-10, X46Cr13	1.4305, 1.4301, 1.4034	≤ 650 N/mm ²		40 – 80	40 – 80	40 – 80
M2	Rostfreie Stähle Stainless steels	X6CrNiMoTi17-12-2, X2CrNiMo17-12-2, X4CrNiMo16-5-1	1.4571, 1.4404, 1.4418	> 650 N/mm ²		30 – 60	30 – 60	30 – 60
K1	Gusseisen Cast iron	EN-GJL200 (GG20), EN-GJLZ (GG40), EN-GJS-400-15 (GGG40)	0.6020, 0.6040, 0.7040	≤ 450 N/mm ²		110 – 130	140 – 180	200 – 220
K2	Gusseisen Cast iron	EN-GJS-600-3 (GGG60), EN-GJS-700-2 (GGG70)	0.7060, 0.7070	> 450 N/mm ²		90 – 110	120 – 150	160 – 180
S1	Titan & Titanlegierungen Titanium & titanium alloys	TiAl6V4	3.7165			50 – 60	60 – 80	80 – 90
S2	Warmfeste Legierungen High Temp alloys	Inconel; NIMONIC		800 – 1700 N/mm ²		30 – 40	30 – 40	30 – 40
N1	Alu-Knetlegierungen Wrought aluminum alloys	AlMg1	3.3315		Si < 9%	120 – 240	120 – 240	120 – 240
N2	Alu-Gusslegierungen Aluminum cast alloys	G-Alsi12	3.2581		Si > 9%	120 – 240	120 – 240	120 – 240
H1	Gehärtete Stähle Hardened steels				45 – 55 HRC	40 – 60	60 – 80	60 – 80

Schnittdaten dienen als Richtwerte und müssen dem Bearbeitungsumfeld angepasst werden.
Cutting data are reference values and need to be adjusted according to the application area.

Vorschubtablette fz (mm/Zahn) abhängig von D1 und Schnittbreite ae / Feed per tooth (mm/tooth) in relation with D1 and cutting width ae

	ø 10	ø 12	ø 16	ø 20
fz	0,03 – 0,09	0,03 – 0,10	0,04 – 0,12	0,05 – 0,13

Schnittdaten Basis zylindrische Verlängerung kurz, Schnittdaten bei längeren Auskragungen anpassen.
Cutting data is based on cylindrical extensions short, cutting data for long overhang need to be adjusted.

F1004MN – DUO-LOCK® HAIMER MILL Power Series FASE/CHAMFER

Technische Daten und Produkteigenschaften/Technical data and Product characteristics



Eigenschaften Characteristics	Anwendung Application	Kühlung Coolant

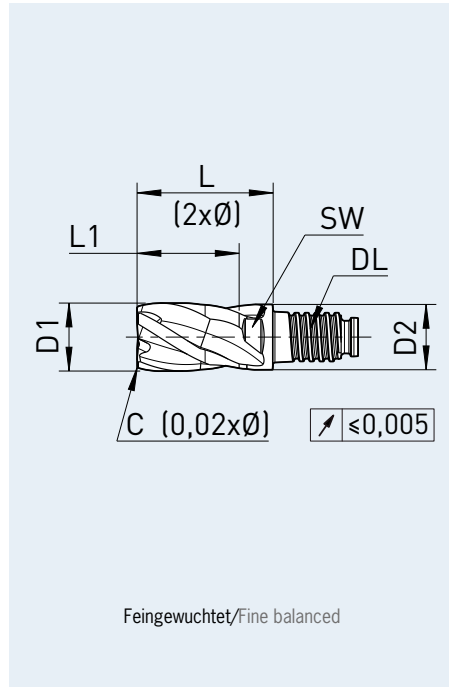

Material – Merkmale/Material – characteristics

Haupteinsatz
Main Material



auch geeignet für
also suitable for





- Halsabsatz für längere Eingriffstiefe
- Zentrumschneide
- Ungleiche Schneidenteilung
- Beste Längenwiederholgenauigkeit
- Polierte Span- und Freiflächen
- Neck for higher cutting depth
- Center cutting
- Unequal cutting edge
- Best length repeatability
- Polished flute and relief

Artikel-Code Article-Code	Qualität Quality	Duo-Lock Größe Size	D1 (f9) D1 (f9) [mm]	Schneidecke Cutting edge	Größe Size [mm]	L1 max. L1 max. [mm]	L L [mm]	D2 D2 [mm]	SW AF [mm]	Drehmoment Torque [N/m]
DL10F1004MN1000C..	DA	DL10	10,00	C	0,20	15	20	9,6	SW8	20
DL12F1004MN1200C..	DA	DL12	12,00	C	0,24	18	24	11,5	SW9,5	30
DL16F1004MN1600C..	DA	DL16	16,00	C	0,32	24	32	15,5	SW13	60
DL20F1004MN2000C..	DA	DL20	20,00	C	0,40	30	40	19,3	SW16	80
DL25F1004MN2500C..	DA	DL25	25,00	C	0,50	37,5	50	24,0	SW21	100
DL32F1004MN3200C..	DA	DL32	32,00	C	0,64	48	64	31,0	SW28	130

Bestellnummer = Artikel-Code + Qualität.
Order No. = Article Code + Quality.

F1004MN – DUO-LOCK® HAIMER MILL Power Series FASE KÜHLUNG RADIAL/CHAMFER COOLING RADIAL

Schnittdaten/Cutting data

HAIMER Werkstoff Gruppen HAIMER Material groups	Beispiel Werkstoffe Example material	DIN DIN	Werkstoffnr. Material no.	Werkstoff Information Material information		Schnittbreite/Cutting width		
				Zugfestigkeit Tensile strength	Inhalt/Härte Content/ Hardness			
						Schnittgeschwindigkeit Vc (m/min) Cutting speed Vc (m/min)		
P1	Allg. Bau-, Einsatzstähle General construction steels	S235JR (RST37-2), E295 (St 50-2), C45	1.0038, 1.0050, 1.0503	≤ 800 N/mm ²	bis 25 HRC up to 25 HRC	170 – 200	210 – 240	250 – 270
P2	Werkzeug/Vergütungsstähle Heat treated steels	X38CrMoV5-3, X153CrMoV12, X100CrMoV5, 42CrMo4	1.2367, 1.2379, 1.2363, 1.7225	> 800 N/mm ²	bis 45 HRC up to 45 HRC	90 – 110	110 – 130	130 – 150
M1	Rostfreie Stähle Stainless steels	X8CrNiS18-9, X5CrNi18-10, X46Cr13	1.4305, 1.4301, 1.4034	≤ 650 N/mm ²		40 – 80	40 – 80	40 – 80
M2	Rostfreie Stähle Stainless steels	X6CrNiMoTi17-12-2, X2CrNiMo17-12-2, X4CrNiMo16-5-1	1.4571, 1.4404, 1.4418	> 650 N/mm ²		30 – 60	30 – 60	30 – 60
K1	Gusseisen Cast iron	EN-GJL200 (GG20), EN-GJLZ (GG40), EN-GJS-400-15 (GGG40)	0.6020, 0.6040, 0.7040	≤ 450 N/mm ²		110 – 130	140 – 180	200 – 220
K2	Gusseisen Cast iron	EN-GJS-600-3 (GGG60), EN-GJS-700-2 (GGG70)	0.7060, 0.7070	> 450 N/mm ²		90 – 110	120 – 150	160 – 180
S1	Titan & Titanlegierungen Titanium & titanium alloys	TiAl6V4	3.7165			50 – 60	60 – 80	80 – 90
S2	Warmfeste Legierungen High Temp alloys	Inconel; NIMONIC		800 – 1700 N/mm ²		30 – 40	30 – 40	30 – 40
N1	Alu-Knetlegierungen Wrought aluminum alloys	AlMg1	3.3315		Si < 9%	120 – 240	120 – 240	120 – 240
N2	Alu-Gusslegierungen Aluminum cast alloys	G-Alsi12	3.2581		Si > 9%	120 – 240	120 – 240	120 – 240
H1	Gehärtete Stähle Hardened steels				45 – 55 HRC	40 – 60	60 – 80	60 – 80

Schnittdaten dienen als Richtwerte und müssen dem Bearbeitungsumfeld angepasst werden.
Cutting data are reference values and need to be adjusted according to the application area.

Vorschubtablette fz (mm/Zahn) abhängig von D1 und Schnittbreite ae /Feed per tooth (mm/tooth) in relation with D1 and cutting width ae

	ø 10	ø 12	ø 16	ø 20
fz	0,03 – 0,09	0,03 – 0,10	0,04 – 0,12	0,05 – 0,13

Schnittdaten Basis zylindrische Verlängerung kurz, Schnittdaten bei längeren Auskrägungen anpassen.
Cutting data is based on cylindrical extensions short, cutting data for long overhang need to be adjusted.

F1004MN – DUO-LOCK® HAIMER MILL Power Series FASE KÜHLUNG RADIAL/CHAMFER COOLING RADIAL

Technische Daten und Produkteigenschaften/Technical data and Product characteristics



Eigenschaften Characteristics	Anwendung Application	Kühlung Coolant

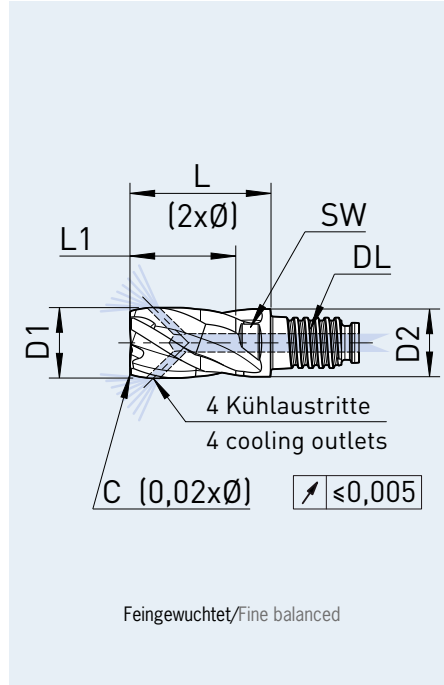

Material – Merkmale/Material – characteristics

Hauptmaterial
Main Material



auch geeignet für
also suitable for



- Innenkühlung radial
- Halsabsatz für längere Eingriffstiefe
- Zentrumschneide
- Ungleiche Schneidenteilung
- Beste Längenwiederholgenauigkeit
- Polierte Span- und Freiflächen

- Inner cooling radial
- Neck for higher cutting depth
- Center cutting
- Unequal cutting edge
- Best length repeatability
- Polished flute and relief

Artikel-Code Article-Code	Qualität Quality	Kühlung Cooling	Duo-Lock Größe Size	D1 (f9) D1 (f9) [mm]	Schneidecke Cutting edge	Größe Size [mm]	L1 max. L1 max. [mm]	L L [mm]	D2 D2 [mm]	SW AF [mm]	Drehmoment Torque [N/m]
DL10F1004MN1000C..	DA	KR	DL10	10,00	C	0,20	15	20	9,6	SW8	20
DL12F1004MN1200C..	DA	KR	DL12	12,00	C	0,24	18	24	11,5	SW9,5	30
DL16F1004MN1600C..	DA	KR	DL16	16,00	C	0,32	24	32	15,5	SW13	60
DL20F1004MN2000C..	DA	KR	DL20	20,00	C	0,40	30	40	19,3	SW16	80
DL25F1004MN2500C..	DA	KR	DL25	25,00	C	0,50	37,5	50	24,0	SW21	100
DL32F1004MN3200C..	DA	KR	DL32	32,00	C	0,64	48	64	31,0	SW28	130

Bestellnummer = Artikel-Code + Qualität + Kühlung.
Order No. = Article Code + Quality + Cooling.

F1004MN – DUO-LOCK® HAIMER MILL Power Series ECKENRADIUS/CORNER RADIUS

Schnittdaten/Cutting data

HAIMER Werkstoff Gruppen HAIMER Material groups	Beispiel Werkstoffe Example material	DIN DIN	Werkstoffnr. Material no.	Werkstoff Information Material information		Schnittbreite/Cutting width		
				Zugfestigkeit Tensile strength	Inhalt/Härte Content/ Hardness	Schnittgeschwindigkeit Vc (m/min) Cutting speed Vc (m/min)		
P1	Allg. Bau-, Einsatzstähle General construction steels	S235JR (RST37-2), E295 (St 50-2), C45	1.0038, 1.0050, 1.0503	≤ 800 N/mm ²	bis 25 HRC up to 25 HRC	20	30	40
P2	Werkzeug/Vergütungsstähle Heat treated steels	X38CrMoV5-3, X153CrMoV12, X100CrMoV5, 42CrMo4	1.2367, 1.2379, 1.2363, 1.7225	> 800 N/mm ²	bis 45 HRC up to 45 HRC	20	30	40
M1	Rostfreie Stähle Stainless steels	X8CrNiS18-9, X5CrNi18-10, X46Cr13	1.4305, 1.4301, 1.4034	≤ 650 N/mm ²		10 – 20	10 – 20	10 – 20
M2	Rostfreie Stähle Stainless steels	X6CrNiMoTi17-12-2, X2CrNiMo17-12-2, X4CrNiMo16-5-1	1.4571, 1.4404, 1.4418	> 650 N/mm ²		10 – 20	10 – 20	10 – 20
K1	Gusseisen Cast iron	EN-GJL200 (GG20), EN-GJLZ (GG40), EN- GJS-400-15 (GGG40)	0.6020, 0.6040, 0.7040	≤ 450 N/mm ²		20 – 30	20 – 30	20 – 30
K2	Gusseisen Cast iron	EN-GJS-600-3 (GGG60), EN-GJS-700-2 (GGG70)	0.7060, 0.7070	> 450 N/mm ²		20 – 30	20 – 30	20 – 30
S1	Titan & Titanlegierungen Titanium & titanium alloys	TiAl6V4	3.7165			10	10	20
S2	Warmfeste Legierungen High Temp alloys	Inconel; NIMONIC		800 – 1700 N/mm ²		10	10	20
N1	Alu-Knetlegierungen Wrought aluminum alloys	AlMg1	3.3315		Si < 9%	300 – 400	300 – 400	400 – 500
N2	Alu-Gusslegierungen Aluminum cast alloys	G-Alsi12	3.2581		Si > 9%	300 – 400	300 – 400	400 – 500

Schnittdaten dienen als Richtwerte und müssen dem Bearbeitungsumfeld angepasst werden.
Cutting data are reference values and need to be adjusted according to the application area.

Vorschubtablette fz (mm/Zahn) abhängig von D1 und Schnittbreite ae / Feed per tooth (mm/tooth) in relation with D1 and cutting width ae				
	ø 10	ø 12	ø 16	ø 20
fz	0,03 – 0,09	0,03 – 0,10	0,04 – 0,12	0,05 – 0,13

Schnittdaten Basis zylindrische Verlängerung kurz, Schnittdaten bei längeren Auskrägungen anpassen.
Cutting data is based on cylindrical extensions short, cutting data for long overhang need to be adjusted.

F1004MN – DUO-LOCK® HAIMER MILL Power Series ECKENRADIUS/CORNER RADIUS

Technische Daten und Produkteigenschaften/Technical data and Product characteristics



Eigenschaften Characteristics	Anwendung Application	Kühlung Coolant

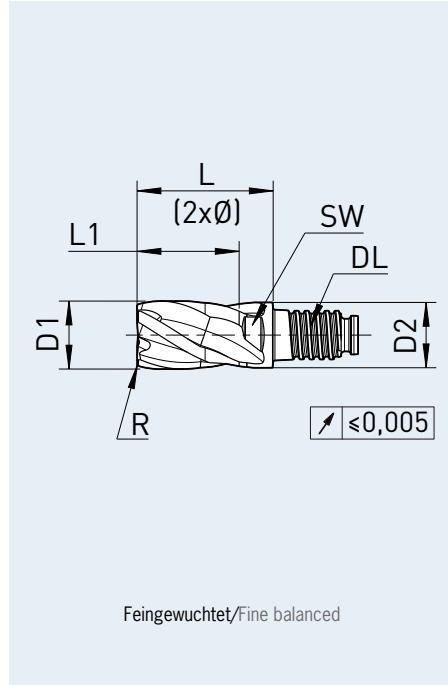

Material – Merkmale/Material – characteristics

Haupteinsatz
Main Material



auch geeignet für
also suitable for



- Halsabsatz für längere Eingriffstiefe
- Zentrumschneide
- Ungleiche Schneidenteilung
- Beste Längenwiederholgenauigkeit
- Polierte Span- und Freiflächen

- Neck for higher cutting depth
- Center cutting
- Unequal cutting edge
- Best length repeatability
- Polished flute and relief

Artikel-Code Article-Code	Qualität Quality	Duo-LOCK Größe Size	D1 (f9) D1 (f9) [mm]	Schneidecke Cutting edge	R R [mm]	L1 max. L1 max. [mm]	L L [mm]	D2 D2 [mm]	SW AF [mm]	Drehmoment Torque [N/m]
DL10F1004MN1000R0.30..	D-	DL10	10,00	R	0,3	15	20	9,6	SW8	20
DL10F1004MN1000R0.50..	D-	DL10	10,00	R	0,5	15	20	9,6	SW8	20
DL10F1004MN1000R0.80..	D-	DL10	10,00	R	0,8	15	20	9,6	SW8	20
DL10F1004MN1000R1.00..	D-	DL10	10,00	R	1,0	15	20	9,6	SW8	20
DL10F1004MN1000R1.50..	D-	DL10	10,00	R	1,5	15	20	9,6	SW8	20
DL10F1004MN1000R2.00..	D-	DL10	10,00	R	2,0	15	20	9,6	SW8	20
DL10F1004MN1000R2.50..	D-	DL10	10,00	R	2,5	15	20	9,6	SW8	20
DL12F1004MN1200R0.50..	D-	DL12	12,00	R	0,5	18	24	11,5	SW9,5	30
DL12F1004MN1200R0.80..	D-	DL12	12,00	R	0,8	18	24	11,5	SW9,5	30
DL12F1004MN1200R1.00..	D-	DL12	12,00	R	1,0	18	24	11,5	SW9,5	30
DL12F1004MN1200R1.50..	D-	DL12	12,00	R	1,5	18	24	11,5	SW9,5	30
DL12F1004MN1200R2.00..	D-	DL12	12,00	R	2,0	18	24	11,5	SW9,5	30
DL12F1004MN1200R2.50..	D-	DL12	12,00	R	2,5	18	24	11,5	SW9,5	30
DL12F1004MN1200R3.00..	D-	DL12	12,00	R	3,0	18	24	11,5	SW9,5	30

⇒ Weitere Artikel siehe nächste Seite/Turn page for more articles

Bestellnummer = Artikel-Code + Qualität.
Order No. = Article Code + Quality.

F1004MN – DUO-LOCK® HAIMER MILL Power Series ECKENRADIUS/CORNER RADIUS

Schnittdaten/Cutting data

HAIMER Werkstoff Gruppen HAIMER Material groups	Beispiel Werkstoffe Example material	DIN DIN	Werkstoffnr. Material no.	Werkstoff Information Material information		Schnittbreite/Cutting width		
				Zugfestigkeit Tensile strength	Inhalt/Härte Content/ Hardness	Schnittgeschwindigkeit Vc (m/min) Cutting speed Vc (m/min)		
P1	Allg. Bau-, Einsatzstähle General construction steels	S235JR (RST37-2), E295 (St 50-2), C45	1.0038, 1.0050, 1.0503	≤ 800 N/mm ²	bis 25 HRC up to 25 HRC	20	30	40
P2	Werkzeug/Vergütungsstähle Heat treated steels	X38CrMoV5-3, X153CrMoV12, X100CrMoV5, 42CrMo4	1.2367, 1.2379, 1.2363, 1.7225	> 800 N/mm ²	bis 45 HRC up to 45 HRC	20	30	40
M1	Rostfreie Stähle Stainless steels	X8CrNiS18-9, X5CrNi18-10, X46Cr13	1.4305, 1.4301, 1.4034	≤ 650 N/mm ²		10 – 20	10 – 20	10 – 20
M2	Rostfreie Stähle Stainless steels	X6CrNiMoTi17-12-2, X2CrNiMo17-12-2, X4CrNiMo16-5-1	1.4571, 1.4404, 1.4418	> 650 N/mm ²		10 – 20	10 – 20	10 – 20
K1	Gusseisen Cast iron	EN-GJL200 (GG20), EN-GJLZ (GG40), EN- GJS-400-15 (GGG40)	0.6020, 0.6040, 0.7040	≤ 450 N/mm ²		20 – 30	20 – 30	20 – 30
K2	Gusseisen Cast iron	EN-GJS-600-3 (GGG60), EN-GJS-700-2 (GGG70)	0.7060, 0.7070	> 450 N/mm ²		20 – 30	20 – 30	20 – 30
S1	Titan & Titanlegierungen Titanium & titanium alloys	TiAl6V4	3.7165			10	10	20
S2	Warmfeste Legierungen High Temp alloys	Inconel; NIMONIC		800 – 1700 N/ mm ²		10	10	20
N1	Alu-Knetlegierungen Wrought aluminum alloys	AlMg1	3.3315		Si < 9%	300 – 400	300 – 400	400 – 500
N2	Alu-Gusslegierungen Aluminum cast alloys	G-Alsi12	3.2581		Si > 9%	300 – 400	300 – 400	400 – 500

Schnittdaten dienen als Richtwerte und müssen dem Bearbeitungsumfeld angepasst werden.
Cutting data are reference values and need to be adjusted according to the application area.

Vorschubtablette fz (mm/Zahn) abhängig von D1 und Schnittbreite ae /Feed per tooth (mm/tooth) in relation with D1 and cutting width ae				
	ø 10	ø 12	ø 16	ø 20
fz	0,03 – 0,09	0,03 – 0,10	0,04 – 0,12	0,05 – 0,13

Schnittdaten Basis zylindrische Verlängerung kurz, Schnittdaten bei längeren Auskrägungen anpassen.
Cutting data is based on cylindrical extensions short, cutting data for long overhang need to be adjusted.

F1004MN – DUO-LOCK® HAIMER MILL Power Series ECKENRADIUS/CORNER RADIUS

Technische Daten und Produkteigenschaften/Technical data and Product characteristics



Eigenschaften Characteristics	Anwendung Application	Kühlung Coolant

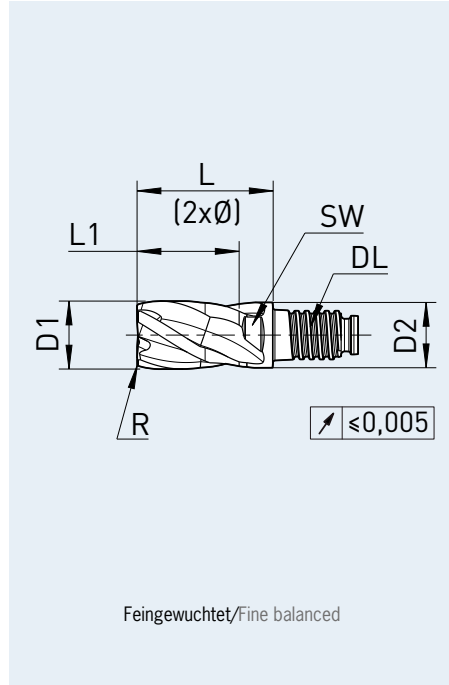

Material – Merkmale/Material – characteristics

Haupteinsatz
Main Material



auch geeignet für
also suitable for



- Halsabsatz für längere Eingriffstiefe
- Zentrumschneide
- Ungleiche Schneidenteilung
- Beste Längenwiederholgenauigkeit
- Polierte Span- und Freiflächen



- Neck for higher cutting depth
- Center cutting
- Unequal cutting edge
- Best length repeatability
- Polished flute and relief

Artikel-Code Article-Code	Qualität Quality	Duo-LOCK Größe Size	D1 (f9) D1 (f9) [mm]	Schneidecke Cutting edge	R R [mm]	L1 max. L1 max. [mm]	L L [mm]	D2 D2 [mm]	SW AF [mm]	Drehmoment Torque [N/m]
DL12F1004MN1200R4.00..	D-	DL12	12,00	R	4,0	18	24	11,5	SW9,5	30
DL16F1004MN1600R0.50..	D-	DL16	16,00	R	0,5	24	32	15,5	SW13	60
DL16F1004MN1600R0.80..	D-	DL16	16,00	R	0,8	24	32	15,5	SW13	60
DL16F1004MN1600R1.00..	D-	DL16	16,00	R	1,0	24	32	15,5	SW13	60
DL16F1004MN1600R2.00..	D-	DL16	16,00	R	2,0	24	32	15,5	SW13	60
DL16F1004MN1600R2.50..	D-	DL16	16,00	R	2,5	24	32	15,5	SW13	60
DL16F1004MN1600R3.00..	D-	DL16	16,00	R	3,0	24	32	15,5	SW13	60
DL16F1004MN1600R4.00..	D-	DL16	16,00	R	4,0	24	32	15,5	SW13	60
DL20F1004MN2000R0.50..	D-	DL20	20,00	R	0,5	30	40	19,3	SW16	80
DL20F1004MN2000R0.80..	D-	DL20	20,00	R	0,8	30	40	19,3	SW16	80
DL20F1004MN2000R1.00..	D-	DL20	20,00	R	1,0	30	40	19,3	SW16	80
DL20F1004MN2000R2.00..	D-	DL20	20,00	R	2,0	30	40	19,3	SW16	80
DL20F1004MN2000R2.50..	D-	DL20	20,00	R	2,5	30	40	19,3	SW16	80
DL20F1004MN2000R3.00..	D-	DL20	20,00	R	3,0	30	40	19,3	SW16	80
DL20F1004MN2000R4.00..	D-	DL20	20,00	R	4,0	30	40	19,3	SW16	80

Bestellnummer = Artikel-Code + Qualität.
Order No. = Article Code + Quality.

F1004MN – DUO-LOCK® HAIMER MILL Power Series ECKENRADIUS/CORNER RADIUS

Schnittdaten/Cutting data

HAIMER Werkstoff Gruppen HAIMER Material groups	Beispiel Werkstoffe Example material	Werkstoffnr. Material no.	Werkstoff Information Material information		Schnittbreite/Cutting width			
			Zugfestigkeit Tensile strength	Inhalt/Härte Content/ Hardness				
					Schnittgeschwindigkeit Vc (m/min) Cutting speed Vc (m/min)			
P1	Allg. Bau-, Einsatzstähle General construction steels	S235JR (RST37-2), E295 (St 50-2), C45	1.0038, 1.0050, 1.0503	≤ 800 N/mm ²	bis 25 HRC up to 25 HRC	170 – 200	210 – 240	250 – 270
P2	Werkzeug/ Vergütungsstähle Heat treated steels	X38CrMoV5-3, X153CrMoV12, X100CrMoV5, 42CrMo4	1.2367, 1.2379, 1.2363, 1.7225	> 800 N/mm ²	bis 45 HRC up to 45 HRC	90 – 110	110 – 130	130 – 150
M1	Rostfreie Stähle Stainless steels	X8CrNiS18-9, X5CrNi18-10, X46Cr13	1.4305, 1.4301, 1.4034	≤ 650 N/mm ²		40 – 80	40 – 80	40 – 80
M2	Rostfreie Stähle Stainless steels	X6CrNiMoTi17-12-2, X2CrNiMo17-12-2, X4CrNiMo16-5-1	1.4571, 1.4404, 1.4418	> 650 N/mm ²		30 – 60	30 – 60	30 – 60
K1	Gusseisen Cast iron	EN-GJL200 (GG20), EN-GJLZ (GG40), EN-GJS-400-15 (GGG40)	0.6020, 0.6040, 0.7040	≤ 450 N/mm ²		110 – 130	140 – 180	200 – 220
K2	Gusseisen Cast iron	EN-GJS-600-3 (GGG60), EN-GJS-700-2 (GGG70)	0.7060, 0.7070	> 450 N/mm ²		90 – 110	120 – 150	160 – 180
S1	Titan & Titanlegierungen Titanium & titanium alloys	TiAl6V4	3.7165			50 – 60	60 – 80	80 – 90
S2	Warmfeste Legierungen High Temp alloys	Inconel; NIMONIC		800 – 1700 N/mm ²		30 – 40	30 – 40	30 – 40
N1	Alu-Knetlegierungen Wrought aluminum alloys	AlMg1	3.3315		Si < 9%	120 – 240	120 – 240	120 – 240
N2	Alu-Gusslegierungen Aluminum cast alloys	G-Alsi12	3.2581		Si > 9%	120 – 240	120 – 240	120 – 240
H1	Gehärtete Stähle Hardened steels				45 – 55 HRC	40 – 60	60 – 80	60 – 80

Schnittdaten dienen als Richtwerte und müssen dem Bearbeitungsumfeld angepasst werden.
Cutting data are reference values and need to be adjusted according to the application area.

Vorschubtablette fz (mm/Zahn) abhängig von D1 und Schnittbreite ae / Feed per tooth (mm/tooth) in relation with D1 and cutting width ae

	ø 10	ø 12	ø 16	ø 20
fz	0,03 – 0,09	0,03 – 0,10	0,04 – 0,12	0,05 – 0,13

Schnittdaten Basis zylindrische Verlängerung kurz, Schnittdaten bei längeren Auskrägungen anpassen.
Cutting data is based on cylindrical extensions short, cutting data for long overhang need to be adjusted.

F1004MN – DUO-LOCK® HAIMER MILL Power Series ECKENRADIUS/CORNER RADIUS

Technische Daten und Produkteigenschaften/Technical data and Product characteristics



Eigenschaften Characteristics	Anwendung Application	Kühlung Coolant

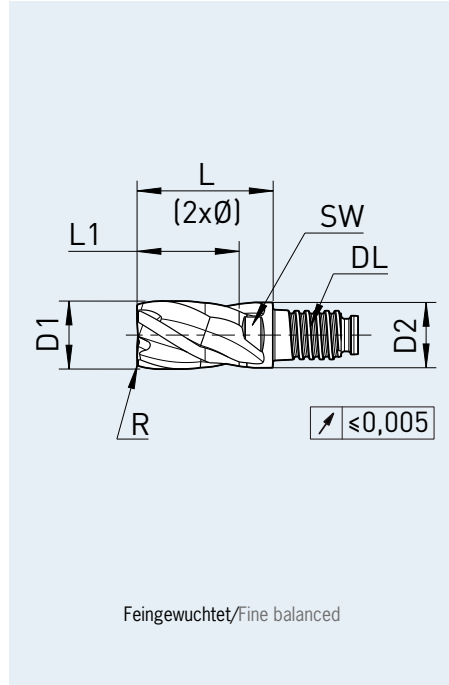

Material – Merkmale/Material – characteristics

Haupteinsatz
Main Material



auch geeignet für
also suitable for



- Halsabsatz für längere Eingriffstiefe
- Zentrumschneide
- Ungleiche Schneidenteilung
- Beste Längenwiederholgenauigkeit
- Polierte Span- und Freiflächen

- Neck for higher cutting depth
- Center cutting
- Unequal cutting edge
- Best length repeatability
- Polished flute and relief



Artikel-Code Article-Code	Qualität Quality	Duo-LOCK Größe Size	D1 (f9) D1 (f9) [mm]	Schneidecke Cutting edge	R R [mm]	L1 max. L1 max. [mm]	L L [mm]	D2 D2 [mm]	SW AF [mm]	Drehmoment Torque [N/m]
DL10F1004MN1000R0.30..	DA	DL10	10,00	R	0,3	15	20	9,6	SW8	20
DL10F1004MN1000R0.50..	DA	DL10	10,00	R	0,5	15	20	9,6	SW8	20
DL10F1004MN1000R0.80..	DA	DL10	10,00	R	0,8	15	20	9,6	SW8	20
DL10F1004MN1000R1.00..	DA	DL10	10,00	R	1,0	15	20	9,6	SW8	20
DL10F1004MN1000R1.50..	DA	DL10	10,00	R	1,5	15	20	9,6	SW8	20
DL10F1004MN1000R2.00..	DA	DL10	10,00	R	2,0	15	20	9,6	SW8	20
DL10F1004MN1000R2.50..	DA	DL10	10,00	R	2,5	15	20	9,6	SW8	20
DL12F1004MN1200R0.50..	DA	DL12	12,00	R	0,5	18	24	11,5	SW9,5	30
DL12F1004MN1200R0.80..	DA	DL12	12,00	R	0,8	18	24	11,5	SW9,5	30
DL12F1004MN1200R1.00..	DA	DL12	12,00	R	1,0	18	24	11,5	SW9,5	30
DL12F1004MN1200R1.50..	DA	DL12	12,00	R	1,5	18	24	11,5	SW9,5	30
DL12F1004MN1200R2.00..	DA	DL12	12,00	R	2,0	18	24	11,5	SW9,5	30
DL12F1004MN1200R2.50..	DA	DL12	12,00	R	2,5	18	24	11,5	SW9,5	30
DL12F1004MN1200R3.00..	DA	DL12	12,00	R	3,0	18	24	11,5	SW9,5	30

↔ Weitere Artikel siehe nächste Seite/Turn page for more articles

Bestellnummer = Artikel-Code + Qualität.
Order No. = Article Code + Quality.

F1004MN – DUO-LOCK® HAIMER MILL Power Series ECKENRADIUS/CORNER RADIUS

Schnittdaten/Cutting data

HAIMER Werkstoff Gruppen HAIMER Material groups	Beispiel Werkstoffe Example material	Werkstoffnr. Material no.	Werkstoff Information Material information		Schnittbreite/Cutting width			
			Zugfestigkeit Tensile strength	Inhalt/Härte Content/ Hardness				
					Schnittgeschwindigkeit Vc (m/min) Cutting speed Vc (m/min)			
P1	Allg. Bau-, Einsatzstähle General construction steels	S235JR (RST37-2), E295 (St 50-2), C45	1.0038, 1.0050, 1.0503	≤ 800 N/mm ²	bis 25 HRC up to 25 HRC	170 – 200	210 – 240	250 – 270
P2	Werkzeug/Vergütungsstähle Heat treated steels	X38CrMoV5-3, X153CrMoV12, X100CrMoV5, 42CrMo4	1.2367, 1.2379, 1.2363, 1.7225	> 800 N/mm ²	bis 45 HRC up to 45 HRC	90 – 110	110 – 130	130 – 150
M1	Rostfreie Stähle Stainless steels	X8CrNiS18-9, X5CrNi18-10, X46Cr13	1.4305, 1.4301, 1.4034	≤ 650 N/mm ²		40 – 80	40 – 80	40 – 80
M2	Rostfreie Stähle Stainless steels	X6CrNiMoTi17-12-2, X2CrNiMo17-12-2, X4CrNiMo16-5-1	1.4571, 1.4404, 1.4418	> 650 N/mm ²		30 – 60	30 – 60	30 – 60
K1	Gusseisen Cast iron	EN-GJL200 (GG20), EN-GJLZ (GG40), EN-GJS-400-15 (GGG40)	0.6020, 0.6040, 0.7040	≤ 450 N/mm ²		110 – 130	140 – 180	200 – 220
K2	Gusseisen Cast iron	EN-GJS-600-3 (GGG60), EN-GJS-700-2 (GGG70)	0.7060, 0.7070	> 450 N/mm ²		90 – 110	120 – 150	160 – 180
S1	Titan & Titanlegierungen Titanium & titanium alloys	TiAl6V4	3.7165			50 – 60	60 – 80	80 – 90
S2	Warmfeste Legierungen High Temp alloys	Inconel; NIMONIC		800 – 1700 N/mm ²		30 – 40	30 – 40	30 – 40
N1	Alu-Knetlegierungen Wrought aluminum alloys	AlMg1	3.3315		Si < 9%	120 – 240	120 – 240	120 – 240
N2	Alu-Gusslegierungen Aluminum cast alloys	G-Alsi12	3.2581		Si > 9%	120 – 240	120 – 240	120 – 240
H1	Gehärtete Stähle Hardened steels				45 – 55 HRC	40 – 60	60 – 80	60 – 80

Schnittdaten dienen als Richtwerte und müssen dem Bearbeitungsumfeld angepasst werden.
Cutting data are reference values and need to be adjusted according to the application area.

Vorschubtablette fz (mm/Zahn) abhängig von D1 und Schnittbreite ae / Feed per tooth (mm/tooth) in relation with D1 and cutting width ae

	ø 10	ø 12	ø 16	ø 20
fz	0,03 – 0,09	0,03 – 0,10	0,04 – 0,12	0,05 – 0,13

Schnittdaten Basis zylindrische Verlängerung kurz, Schnittdaten bei längeren Auskragungen anpassen.
Cutting data is based on cylindrical extensions short, cutting data for long overhang need to be adjusted.

F1004MN – DUO-LOCK® HAIMER MILL Power Series ECKENRADIUS/CORNER RADIUS

Technische Daten und Produkteigenschaften/Technical data and Product characteristics



Eigenschaften Characteristics	Anwendung Application	Kühlung Coolant

Feingewuchtet/Fine balanced

Material – Merkmale/Material – characteristics

Haupteinsatz
Main Material



auch geeignet für
also suitable for



- Halsabsatz für längere Eingriffstiefe
- Zentrumschneide
- Ungleiche Schneidenteilung
- Beste Längenwiederholgenauigkeit
- Polierte Span- und Freiflächen
- Neck for higher cutting depth
- Center cutting
- Unequal cutting edge
- Best length repeatability
- Polished flute and relief

Artikel-Code Article-Code	Qualität Quality	Duo-LOCK Größe Size	D1 (f9) D1 (f9) [mm]	Schneidecke Cutting edge	R R [mm]	L1 max. L1 max. [mm]	L L [mm]	D2 D2 [mm]	SW AF [mm]	Drehmoment Torque [N/m]
DL12F1004MN1200R4.00..	DA	DL12	12,00	R	4,0	18	24	11,5	SW9,5	30
DL16F1004MN1600R0.50..	DA	DL16	16,00	R	0,5	24	32	15,5	SW13	60
DL16F1004MN1600R0.80..	DA	DL16	16,00	R	0,8	24	32	15,5	SW13	60
DL16F1004MN1600R1.00..	DA	DL16	16,00	R	1,0	24	32	15,5	SW13	60
DL16F1004MN1600R2.00..	DA	DL16	16,00	R	2,0	24	32	15,5	SW13	60
DL16F1004MN1600R2.50..	DA	DL16	16,00	R	2,5	24	32	15,5	SW13	60
DL16F1004MN1600R3.00..	DA	DL16	16,00	R	3,0	24	32	15,5	SW13	60
DL16F1004MN1600R4.00..	DA	DL16	16,00	R	4,0	24	32	15,5	SW13	60
DL20F1004MN2000R0.50..	DA	DL20	20,00	R	0,5	30	40	19,3	SW16	80
DL20F1004MN2000R0.80..	DA	DL20	20,00	R	0,8	30	40	19,3	SW16	80
DL20F1004MN2000R1.00..	DA	DL20	20,00	R	1,0	30	40	19,3	SW16	80
DL20F1004MN2000R2.00..	DA	DL20	20,00	R	2,0	30	40	19,3	SW16	80
DL20F1004MN2000R2.50..	DA	DL20	20,00	R	2,5	30	40	19,3	SW16	80
DL20F1004MN2000R3.00..	DA	DL20	20,00	R	3,0	30	40	19,3	SW16	80
DL20F1004MN2000R4.00..	DA	DL20	20,00	R	4,0	30	40	19,3	SW16	80

Bestellnummer = Artikel-Code + Qualität.
Order No. = Article Code + Quality.

F1105LL – DUO-ΛOCK® HAIMER MILL Power Series FASE SPANBRECHER/CHAMFER CHIP BREAKER

Schnittdaten/Cutting data

HAIMER Werkstoff Gruppen HAIMER Material groups	Beispiel Werkstoffe Example material	Werkstoffnr. Material no.	Werkstoff Information Material information		Schnittdaten		
			Zugfestigkeit Tensile strength	Inhalt/Härte Content/ Hardness	Schruppen Vc (m/min) Roughing Vc (m/min)	Schlichten Vc (m/min) Finishing Vc (m/min)	
P1	Allg. Bau-, Einsatzstähle General construction steels	S235JR (RST37-2), E295 (St 50-2), C45	1.0038, 1.0050, 1.0503	≤ 800 N/mm ²	bis 25 HRC up to 25 HRC	160 – 220	220 – 280
P2	Werkzeug-/Vergütungsstähle Heat treated steels	X38CrMoV5-3, X153CrMoV12, X100CrMoV5, 42CrMo4	1.2367, 1.2379, 1.2363, 1.7225	> 800 N/mm ²	bis 45 HRC up to 45 HRC	120 – 160	160 – 200
M1	Rostfreie Stähle Stainless steels	X8CrNiS18-9, X5CrNi18-10, X46Cr13	1.4305, 1.4301, 1.4034	≤ 650 N/mm ²		80 – 120	120 – 160
K1	Gusseisen Cast iron	EN-GJL200 (GG20), EN-GJLZ (GG40), EN-GJS-400-15 (GGG40)	0.6020, 0.6040, 0.7040	≤ 450 N/mm ²		120 – 180	180 – 240
K2	Gusseisen Cast iron	EN-GJS-600-3 (GGG60), EN-GJS-700-2 (GGG70)	0.7060, 0.7070	> 450 N/mm ²		80 – 160	160 – 220
S1	Titan & Titanlegierungen Titanium & titanium alloys	TiAl6V4	3.7165			40 – 80	40 – 80
N1	Alu-Knetlegierungen Wrought aluminum alloys	AlMg1	3.3315		Si < 9%	500 – 900	500 – 900
N2	Alu-Gusslegierungen Aluminum cast alloys	G-Alsi12	3.2581		Si > 9%	120 – 350	120 – 350
H1	Gehärtete Stähle Hardened steels				45 – 55 HRC	40 – 60	60 – 80

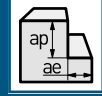

ae = 5% D1
ap = L1 max.

Schnittdaten dienen als Richtwerte und müssen dem Bearbeitungsumfeld angepasst werden.
Cutting data are reference values and need to be adjusted according to the application area.







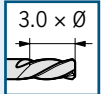

Vorschubtable f _z (mm/Zahn) abhängig von D1 und Schnittbreite ae / Feed per tooth (mm/tooth) in relation with D1 and cutting width ae				
ae 5%	ø 16	ø 20	ø 25	ø 32
f _z	0,04 – 0,12	0,05 – 0,13	0,06 – 0,17	0,07 – 0,20

Schnittdaten Basis zylindrische Verlängerung kurz, Schnittdaten bei längeren Auskragungen anpassen.
Cutting data is based on cylindrical extensions short, cutting data for long overhang need to be adjusted.

F1105LL – DUO-LOCK® HAIMER MILL Power Series FASE SPANBRECHER/CHAMFER CHIP BREAKER

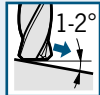
Technische Daten und Produkteigenschaften/Technical data and Product characteristics

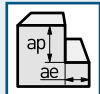

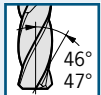
Eigenschaften Characteristics	Anwendung Application	Kühlung Coolant
		
		
		
		

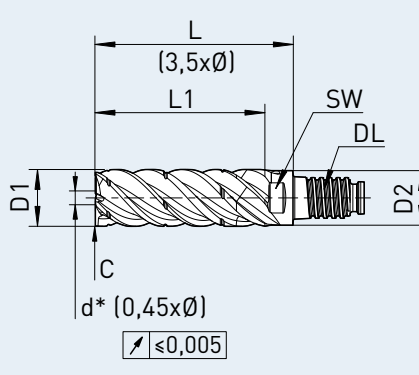

Feingewuchtet/Fine balanced
* nicht zentrumschneidender Durchmesser
* diameter not center cutting

Material – Merkmale/Material – characteristics

Hauptersatz
Main Material



auch geeignet für
also suitable for



- Halsabsatz für längere Eingriffstiefe
- Ungleiche Schneidenteilung
- Beste Längenwiederholgenauigkeit
- Polierte Span- und Freiflächen

- Neck for higher cutting depth
- Unequal cutting edge
- Best length repeatability
- Polished flute and relief

Artikel-Code Article-Code	Qualität Quality	Duo-Lock Größe Size	D1 (h9) D1 (h9) [mm]	Schneidecke Cutting edge	Größe Size [mm]	L1 max. L1 max. [mm]	L L [mm]	D2 D2 [mm]	SW AF [mm]	Drehmoment Torque [N/m]
DL16F1105LL1600C..	DA	DL16	16,00	C	0,50	48	56	15,5	SW13	60
DL20F1105LL2000C..	DA	DL20	20,00	C	0,60	60	70	19,3	SW16	80
DL25F1105LL2500C..	DA	DL25	25,00	C	0,60	75	87,5	24,0	SW21	100
DL32F1105LL3200C..	DA	DL32	32,00	C	0,70	96	112	31,0	SW28	130

Bestellnummer = Artikel-Code + Qualität.
Order No. = Article Code + Quality.

F1105MN – DUO-ΛOCK® HAIMER MILL Power Series

FASE SPANBRECHER/CHAMFER CHIP BREAKER

Schnittdaten/Cutting data

HAIMER Werkstoff Gruppen HAIMER Material groups	Beispiel Werkstoffe Example material	Werkstoffnr. Material no.	Werkstoff Information Material information		Schruppen Vc (m/min) Roughing Vc (m/min)	Schlichten Vc (m/min) Finishing Vc (m/min)	
			Zugfestigkeit Tensile strength	Inhalt/Härte Content/ Hardness			
P1	Allg. Bau-, Einsatzstähle General construction steels	S235JR (RST37-2), E295 (St 50-2), C45	1.0038, 1.0050, 1.0503	≤ 800 N/mm ²	bis 25 HRC up to 25 HRC	160 – 220	220 – 280
P2	Werkzeug-/Vergütungsstähle Heat treated steels	X38CrMoV5-3, X153CrMoV12, X100CrMoV5, 42CrMo4	1.2367, 1.2379, 1.2363, 1.7225	> 800 N/mm ²	bis 45 HRC up to 45 HRC	120 – 160	160 – 200
M1	Rostfreie Stähle Stainless steels	X8CrNiS18-9, X5CrNi18-10, X46Cr13	1.4305, 1.4301, 1.4034	≤ 650 N/mm ²		80 – 120	120 – 160
K1	Gusseisen Cast iron	EN-GJL200 (GG20), EN-GJLZ (GG40), EN-GJS-400-15 (GGG40)	0.6020, 0.6040, 0.7040	≤ 450 N/mm ²		120 – 180	180 – 240
K2	Gusseisen Cast iron	EN-GJS-600-3 (GGG60), EN-GJS-700-2 (GGG70)	0.7060, 0.7070	> 450 N/mm ²		80 – 160	160 – 220
S1	Titan & Titanlegierungen Titanium & titanium alloys	TiAl6V4	3.7165			40 – 80	40 – 80
N1	Alu-Knetlegierungen Wrought aluminum alloys	AlMg1	3.3315		Si < 9%	500 – 900	500 – 900
N2	Alu-Gusslegierungen Aluminum cast alloys	G-Alsi12	3.2581		Si > 9%	120 – 350	120 – 350
H1	Gehärtete Stähle Hardened steels				45 – 55 HRC	40 – 60	60 – 80

Schnittdaten dienen als Richtwerte und müssen dem Bearbeitungsumfeld angepasst werden.
 Cutting data are reference values and need to be adjusted according to the application area.

Vorschubtable f_z (mm/Zahn) abhängig von D1 und Schnittbreite ae / Feed per tooth (mm/tooth) in relation with D1 and cutting width ae







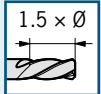

	∅ 10	∅ 12	∅ 16	∅ 20	∅ 25	∅ 32
f _z	0,03 – 0,09	0,03 – 0,10	0,04 – 0,12	0,05 – 0,13	0,06 – 0,17	0,07 – 0,20

Schnittdaten Basis zylindrische Verlängerung kurz, Schnittdaten bei längeren Auskragungen anpassen.
 Cutting data is based on cylindrical extensions short, cutting data for long overhang need to be adjusted.

F1105MN – DUO-LOCK® HAIMER MILL Power Series FASE SPANBRECHER/CHAMFER CHIP BREAKER

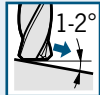
Technische Daten und Produkteigenschaften/Technical data and Product characteristics

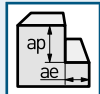

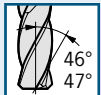
Eigenschaften Characteristics	Anwendung Application	Kühlung Coolant
		
		
		
		

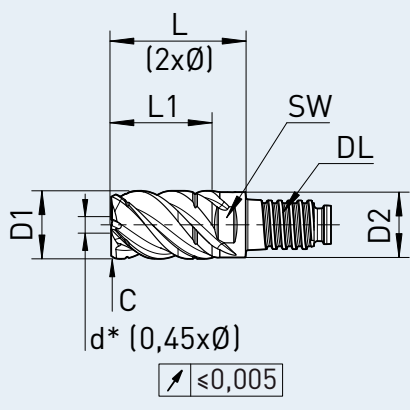

Feingewuchtet/Fine balanced
* nicht zentrumschneidender Durchmesser
* diameter not center cutting

Material – Merkmale/Material – characteristics

Haupteinsatz
Main Material



auch geeignet für
also suitable for



- Halsabsatz für längere Eingriffstiefe
- Ungleiche Schneidenteilung
- Beste Längenwiederholgenauigkeit
- Polierte Span- und Freiflächen

- Neck for higher cutting depth
- Unequal cutting edge
- Best length repeatability
- Polished flute and relief

Artikel-Code Article-Code	Qualität Quality	Duo-Lock Größe Size	D1 (h9) D1 (h9) [mm]	Schneidecke Cutting edge	Größe Size [mm]	L1 max. L1 max. [mm]	L L [mm]	D2 D2 [mm]	SW AF [mm]	Drehmoment Torque [N/m]
DL10F1105MN1000C..	DA	DL10	10,00	C	0,30	15	20	9,6	SW8	20
DL12F1105MN1200C..	DA	DL12	12,00	C	0,30	18	24	11,5	SW9,5	30
DL16F1105MN1600C..	DA	DL16	16,00	C	0,50	24	32	15,5	SW13	60
DL20F1105MN2000C..	DA	DL20	20,00	C	0,60	30	40	19,3	SW16	80
DL25F1105MN2500C..	DA	DL25	25,00	C	0,60	37,5	50	24,0	SW21	100
DL32F1105MN3200C..	DA	DL32	32,00	C	0,70	48	64	31,0	SW28	130

Bestellnummer = Artikel-Code + Qualität.
Order No. = Article Code + Quality.

F2003MN – DUO-ΛOCK® HAIMER MILL SCHARFKANTIG/SHARP CUTTING EDGE

Schnittdaten/Cutting data

HAIMER Werkstoff Gruppen HAIMER Material groups	Beispiel Werkstoffe Example material	Werkstoff Information Material information					
		DIN DIN	Werkstoffnr. Material no.	Zugfestigkeit Tensile strength	Inhalt/Härte Content/ Hardness	Schruppen Vc (m/min) Roughing Vc (m/min)	Schlichten Vc (m/min) Finishing Vc (m/min)
P1	Allg. Bau-, Einsatzstähle General construction steels	S235JR (RST37-2), E295 (St 50-2), C45	1.0038, 1.0050, 1.0503	≤ 800 N/mm ²	bis 25 HRC up to 25 HRC	160 – 220	220 – 280
P2	Werkzeug-/Vergütungsstähle Heat treated steels	X38CrMoV5-3, X153CrMoV12, X100CrMoV5, 42CrMo4	1.2367, 1.2379, 1.2363, 1.7225	> 800 N/mm ²	bis 45 HRC up to 45 HRC	120 – 160	160 – 200
M1	Rostfreie Stähle Stainless steels	X8CrNiS18-9, X5CrNi18-10, X46Cr13	1.4305, 1.4301, 1.4034	≤ 650 N/mm ²		80 – 120	120 – 160
M2	Rostfreie Stähle Stainless steels	X6CrNiMoTi17-12-2, X2CrNiMo17-12-2, X4CrNiMo16-5-1	1.4571, 1.4404, 1.4418	> 650 N/mm ²		60 – 90	90 – 120
K1	Gusseisen Cast iron	EN-GJL200 (GG20), EN-GJLZ (GG40), EN-GJS-400-15 (GGG40)	0.6020, 0.6040, 0.7040	≤ 450 N/mm ²		120 – 180	180 – 240
K2	Gusseisen Cast iron	EN-GJS-600-3 (GGG60), EN-GJS-700-2 (GGG70)	0.7060, 0.7070	> 450 N/mm ²		80 – 160	160 – 220
S1	Titan & Titanlegierungen Titanium & titanium alloys	TiAl6V4	3.7165			40 – 80	40 – 80
S2	Warmfeste Legierungen High Temp alloys	Inconel; NIMONIC		800 – 1700 N/mm ²		30 – 40	30 – 40
N1	Alu-Knetlegierungen Wrought aluminum alloys	AlMg1	3.3315		Si < 9%	500 – 900	500 – 900
N2	Alu-Gusslegierungen Aluminum cast alloys	G-Alsi12	3.2581		Si > 9%	120 – 350	120 – 350
H1	Gehärtete Stähle Hardened steels				45 – 55 HRC	40 – 60	60 – 80

Schnittdaten dienen als Richtwerte und müssen dem Bearbeitungsumfeld angepasst werden.
Cutting data are reference values and need to be adjusted according to the application area.

Vorschubtable f _z (mm/Zahn) abhängig von D1 und Schnittbreite ae / Feed per tooth (mm/tooth) in relation with D1 and cutting width ae										
	ø 2	ø 3	ø 4	ø 5	ø 6	ø 8	ø 10	ø 12	ø 16	ø 20
f _z	0,006 – 0,018	0,009 – 0,027	0,012 – 0,036	0,015 – 0,045	0,018 – 0,054	0,024 – 0,072	0,03 – 0,09	0,03 – 0,10	0,04 – 0,12	0,05 – 0,13

Schnittdaten Basis zylindrische Verlängerung kurz, Schnittdaten bei längeren Auskragungen anpassen.
Cutting data is based on cylindrical extensions short, cutting data for long overhang need to be adjusted.

F2003MN - DUO-LOCK® HAIMER MILL SCHARFKANTIG/SHARP CUTTING EDGE

Technische Daten und Produkteigenschaften/Technical data and Product characteristics



Eigenschaften Characteristics

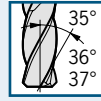
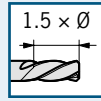

Anwendung Application

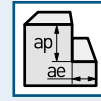
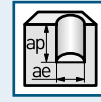
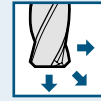

Kühlung Coolant

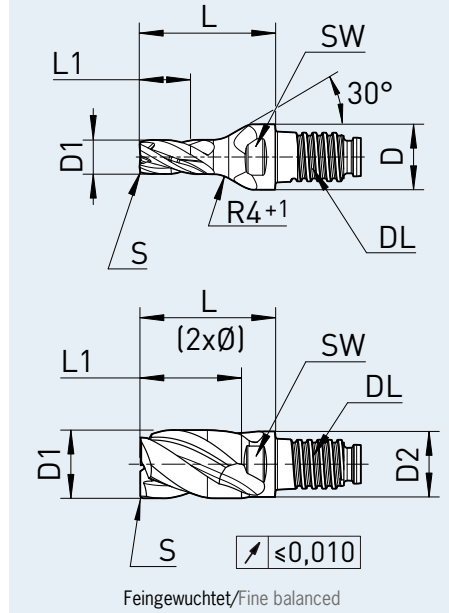

Material – Merkmale/Material – characteristics

Hauptmaterial
Main Material



auch geeignet für
also suitable for



- Halsabsatz für längere Eingriffstiefe
- Zentrumschneide
- Ungleiche Schneidenteilung
- Beste Längenwiederholgenauigkeit
- $\varnothing 2 - \varnothing 8$ mm für universellen Einsatz mit DL10 Schnittstelle (ohne Halsabsatz)

- Neck for higher cutting depth
- Center cutting
- Unequal cutting edge
- Best length repeatability
- $\varnothing 2 - \varnothing 8$ mm for universal use with DL10 interface (without neck)

Artikel-Code Article-Code	Qualität Quality	Duo-Lock Größe Size	D1 (f9) D1 (f9) [mm]	Schneidecke Cutting edge	L1 max. L1 max. [mm]	L L [mm]	D D [mm]	SW AF [mm]	Drehmoment Torque [N/m]
DL10F2003MN0200S..	DA	DL10	2,00	S	3,0	20	9,6	SW8	20
DL10F2003MN0300S..	DA	DL10	3,00	S	4,5	20	9,6	SW8	20
DL10F2003MN0400S..	DA	DL10	4,00	S	6,0	20	9,6	SW8	20
DL10F2003MN0500S..	DA	DL10	5,00	S	7,5	20	9,6	SW8	20
DL10F2003MN0600S..	DA	DL10	6,00	S	9,0	20	9,6	SW8	20
DL10F2003MN0800S..	DA	DL10	8,00	S	12,0	20	9,6	SW8	20
DL10F2003MN1000S..	DA	DL10	10,00	S	15	20	9,6	SW8	20
DL12F2003MN1200S..	DA	DL12	12,00	S	18	24	11,5	SW9,5	30
DL16F2003MN1600S..	DA	DL16	16,00	S	24	32	15,5	SW13	60
DL20F2003MN2000S..	DA	DL20	20,00	S	30	40	19,3	SW16	80

Bestellnummer = Artikel-Code + Qualität.
Order No. = Article Code + Quality.

F2003UK – DUO-ΛOCK® HAIMER MILL SCHARFKANTIG/SHARP CUTTING EDGE

Schnittdaten/Cutting data

HAIMER Werkstoff Gruppen HAIMER Material groups	Beispiel Werkstoffe Example material	Werkstoff Information Material information				Schruppen Vc (m/min) Roughing Vc (m/min)	Schlichten Vc (m/min) Finishing Vc (m/min)
		DIN DIN	Werkstoffnr. Material no.	Zugfestigkeit Tensile strength	Inhalt/Härte Content/ Hardness		
P1	Allg. Bau-, Einsatzstähle General construction steels	S235JR (RST37-2), E295 (St 50-2), C45	1.0038, 1.0050, 1.0503	≤ 800 N/mm ²	bis 25 HRC up to 25 HRC	160 – 220	220 – 280
P2	Werkzeug/ Vergütungsstähle Heat treated steels	X38CrMoV5-3, X153CrMoV12, X100CrMoV5, 42CrMo4	1.2367, 1.2379, 1.2363, 1.7225	> 800 N/mm ²	bis 45 HRC up to 45 HRC	120 – 160	160 – 200
M1	Rostfreie Stähle Stainless steels	X8CrNiS18-9, X5CrNi18-10, X46Cr13	1.4305, 1.4301, 1.4034	≤ 650 N/mm ²		80 – 120	120 – 160
M2	Rostfreie Stähle Stainless steels	X6CrNiMoTi17-12-2, X2CrNiMo17-12-2, X4CrNiMo16-5-1	1.4571, 1.4404, 1.4418	> 650 N/mm ²		60 – 90	90 – 120
K1	Gusseisen Cast iron	EN-GJL200 (GG20), EN- GJLZ (GG40), EN- GJS-400-15 (GGG40)	0.6020, 0.6040, 0.7040	≤ 450 N/mm ²		120 – 180	180 – 240
K2	Gusseisen Cast iron	EN-GJS-600-3 (GGG60), EN-GJS-700-2 (GGG70)	0.7060, 0.7070	> 450 N/mm ²		80 – 160	160 – 220
S1	Titan & Titanlegierungen Titanium & titanium alloys	TiAl6V4	3.7165			40 – 80	40 – 80
S2	Wärmefeste Legierungen High Temp alloys	Inconel; NIMONIC		800 – 1700 N/mm ²		30 – 40	30 – 40
N1	Alu-Knetlegierungen Wrought aluminum alloys	AlMg1	3.3315		Si < 9%	500 – 900	500 – 900
N2	Alu-Gusslegierungen Aluminum cast alloys	G-Alsi12	3.2581		Si > 9%	120 – 350	120 – 350
H1	Gehärtete Stähle Hardened steels				45 – 55 HRC	40 – 60	60 – 80

Schnittdaten dienen als Richtwerte und müssen dem Bearbeitungsumfeld angepasst werden.
Cutting data are reference values and need to be adjusted according to the application area.

Vorschubtable f_z (mm/Zahn) abhängig von D1 und Schnittbreite ae / Feed per tooth (mm/tooth) in relation with D1 and cutting width ae

	∅ 10	∅ 12	∅ 16	∅ 20
f _z	0,03 – 0,09	0,03 – 0,10	0,04 – 0,12	0,05 – 0,13

Schnittdaten Basis zylindrische Verlängerung kurz, Schnittdaten bei längeren Auskragungen anpassen.
Cutting data is based on cylindrical extensions short, cutting data for long overhang need to be adjusted.

F2003UK – DUO-LOCK® HAIMER MILL SCHARFKANTIG/SHARP CUTTING EDGE

Technische Daten und Produkteigenschaften/Technical data and Product characteristics



Eigenschaften Characteristics	Anwendung Application	Kühlung Coolant
0.75 x Ø		
S	3-5°	
Z=3	ap, ae	
35°, 36°, 37°	ap, ae	

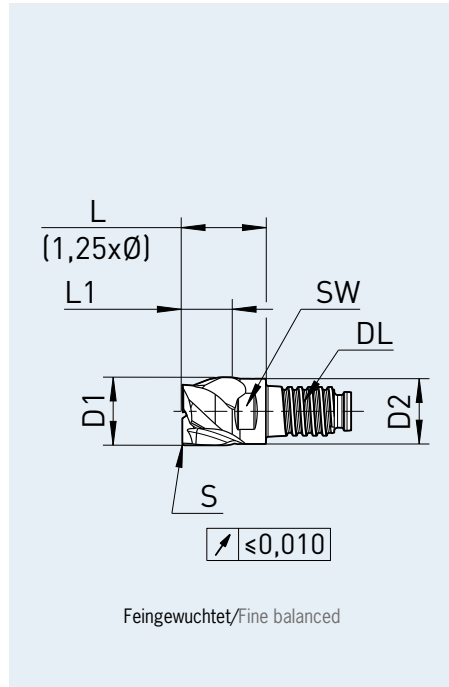

Material – Merkmale/Material – characteristics

Hauptmaterial
Main Material



auch geeignet für
also suitable for



- Halsabsatz für längere Eingriffstiefe
- Zentrumschneide
- Ungleiche Schneidenteilung
- Beste Längenwiederholgenauigkeit

- Neck for higher cutting depth
- Center cutting
- Unequal cutting edge
- Best length repeatability

Artikel-Code Article-Code	Qualität Quality	Duo-Lock Größe Size	D1 (f9) D1 (f9) [mm]	Schneidecke Cutting edge	L1 max. L1 max. [mm]	L L [mm]	D2 D2 [mm]	SW AF [mm]	Drehmoment Torque [N/m]
DL10F2003UK1000S..	DA	DL10	10,00	S	7,5	12,5	9,6	SW8	20
DL12F2003UK1200S..	DA	DL12	12,00	S	9	15	11,5	SW9,5	30
DL16F2003UK1600S..	DA	DL16	16,00	S	12	20	15,5	SW13	60
DL20F2003UK2000S..	DA	DL20	20,00	S	15	25	19,3	SW16	80

Bestellnummer = Artikel-Code + Qualität.
Order No. = Article Code + Quality.

F2004MN – DUO-LOCK® HAIMER MILL FASE/CHAMFER

Schnittdaten/Cutting data

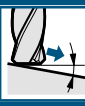
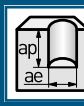
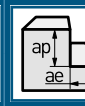
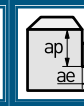
HAIMER Werkstoff Gruppen HAIMER Material groups	Beispiel Werkstoffe Example material	Werkstoffnr. Material no.	Werkstoff Information Material information		Schnittbreite/Cutting width    	Rampe Ramping	Schnittgeschwindigkeit Vc (m/min) Cutting speed Vc (m/min)		
			Zugfestigkeit Tensile strength	Inhalt/Härte Content/ Hardness			ae = 100% D1 ap = 1 x D1	ae = 15% D1 ap = L1 max.	ae = 5% D1 ap = L1 max.
P1 Allg. Bau-, Einsatzstähle General construction steels	S235JR (RST37-2), E295 (St 50-2), C45	1.0038, 1.0050, 1.0503	≤ 800 N/mm²	bis 25 HRC up to 25 HRC		45°	255 – 275	320 – 340	400 – 420
P2 Werkzeug/ Vergütungsstähle Heat treated steels	X38CrMoV5-3, X153CrMoV12, X100CrMoV5, 42CrMo4	1.2367, 1.2379, 1.2363, 1.7225	> 800 N/mm²	bis 45 HRC up to 45 HRC		30°	190 – 210	220 – 240	290 – 310
M1 Rostfreie Stähle Stainless steels	X8CrNiS18-9, X5CrNi18-10, X46Cr13	1.4305, 1.4301, 1.4034	≤ 650 N/mm²			10°	95 – 110	115 – 135	150 – 170
M2 Rostfreie Stähle Stainless steels	X6CrNiMoTi17-12-2, X2CrNiMo17-12-2, X4CrNiMo16-5-1	1.4571, 1.4404, 1.4418	> 650 N/mm²			5°	75 – 90	95 – 105	110 – 130
K1 Gusseisen Cast iron	EN-GJL200 (GG20), EN-GJLZ (GG40), EN-GJS-400-15 (GGG40)	0.6020, 0.6040, 0.7040	≤ 450 N/mm²			45°	160 – 180	180 – 200	210 – 230
K2 Gusseisen Cast iron	EN-GJS-600-3 (GGG60) EN-GJS-700-2 (GGG70)	0.7060, 0.7070	> 450 N/mm²			20°	130 – 150	150 – 170	180 – 200
S1 Titan & Titanlegierungen Titanium & titanium alloys	TiAl6V4	3.7165				10°	50 – 60	60 – 80	80 – 90
S2 Warmfeste Legierungen High Temp alloys	Inconel; NIMONIC		800 – 1700 N/mm²			5°	30 – 40	30 – 40	30 – 40
N1 Alu-Knetlegierungen Wrought aluminum alloys	AlMg1	3.3315		Si < 9%		30°	470 – 490	600 – 630	780 – 820
N2 Alu-Gusslegierungen Aluminum cast alloys	G-Als12	3.2581		Si > 9%		30°	340 – 360	420 – 440	540 – 580
H1 Gehärtete Stähle Hardened steels				45 – 55 HRC		10°	40 – 60	60 – 80	60 – 80

Schnittdaten dienen als Richtwerte und müssen dem Bearbeitungsumfeld angepasst werden.
Beim Bohren wird Entspannen je nach Werkstoff, bei 0,5 – 1 x D empfohlen.
Cutting data are reference values and need to be adjusted according to the application area.
Chip removal recommended for drilling depth 0,5 – 1 x D.

Vorschubtable f _z (mm/Zahn) abhängig von D1 und Schnittbreite ae / Feed per tooth (mm/tooth) in relation with D1 and cutting width ae						
	ø 2	ø 3	ø 4	ø 5	ø 6	ø 8
f _z	0,006 – 0,018	0,009 – 0,027	0,012 – 0,036	0,015 – 0,045	0,018 – 0,054	0,024 – 0,072
	ø 10	ø 12	ø 16	ø 20	ø 25	ø 32
f _z	0,03 – 0,09	0,03 – 0,10	0,04 – 0,12	0,05 – 0,13	0,06 – 0,17	0,07 – 0,20

Schnittdaten Basis zylindrische Verlängerung kurz, Schnittdaten bei längeren Auskragungen anpassen.
Cutting data is based on cylindrical extensions short, cutting data for long overhang need to be adjusted.

F2004MN – DUO-LOCK® HAIMER MILL FASE/CHAMFER

Technische Daten und Produkteigenschaften/Technical data and Product characteristics



Eigenschaften Characteristics	Anwendung Application	Kühlung Coolant

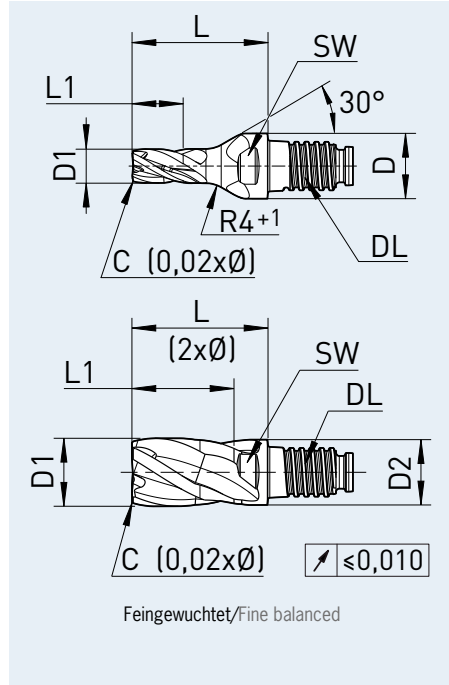

Material – Merkmale/Material – characteristics

Hauptmaterial
Main Material



auch geeignet für
also suitable for

- Halsabsatz für längere Eingriffstiefe
- Zentrumschneide
- Ungleiche Schneidenteilung
- Beste Längenwiederholgenauigkeit
- ø 2 – ø 8 für universellen Einsatz mit DL10 Schnittstelle (ohne Halsabsatz)

- Neck for higher cutting depth
- Center cutting
- Unequal cutting edge
- Best length repeatability
- ø 2 – ø 8 for universal use with DL10 interface (without neck)

Artikel-Code Article-Code	Qualität Quality	Duo-Lock Größe Size	D1 (f9) D1 (f9) [mm]	Schneidecke Cutting edge	Größe Size [mm]	L1 max. L1 max. [mm]	L L [mm]	D D [mm]	SW AF [mm]	Drehmoment Torque [N/m]
DL10F2004MN0200C..	DA	DL10	2,00	C	0,04	3,0	20	9,6	SW8	20
DL10F2004MN0300C..	DA	DL10	3,00	C	0,06	4,5	20	9,6	SW8	20
DL10F2004MN0400C..	DA	DL10	4,00	C	0,08	6,0	20	9,6	SW8	20
DL10F2004MN0500C..	DA	DL10	5,00	C	0,10	7,5	20	9,6	SW8	20
DL10F2004MN0600C..	DA	DL10	6,00	C	0,12	9,0	20	9,6	SW8	20
DL10F2004MN0800C..	DA	DL10	8,00	C	0,16	12,0	20	9,6	SW8	20
DL10F2004MN1000C..	DA	DL10	10,00	C	0,20	15	20	9,6	SW8	20
DL12F2004MN1200C..	DA	DL12	12,00	C	0,24	18	24	11,5	SW9,5	30
DL16F2004MN1600C..	DA	DL16	16,00	C	0,32	24	32	15,5	SW13	60
DL20F2004MN2000C..	DA	DL20	20,00	C	0,40	30	40	19,3	SW16	80
DL25F2004MN2500C..	DA	DL25	25,00	C	0,50	37,5	50	24,0	SW21	100
DL32F2004MN3200C..	DA	DL32	32,00	C	0,64	48	64	31,0	SW28	130

Bestellnummer = Artikel-Code + Qualität.
Order No. = Article Code + Quality.

F2004MN – DUO-LOCK® HAIMER MILL ECKENRADIUS/CORNER RADIUS

Schnittdaten/Cutting data

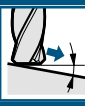
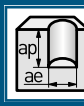
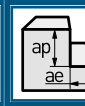
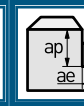
HAIMER Werkstoff Gruppen HAIMER Material groups	Beispiel Werkstoffe Example material	Werkstoffnr. Material no.	Werkstoff Information Material information		Schnittbreite/Cutting width    	Rampe Ramping	Schnittgeschwindigkeit Vc (m/min) Cutting speed Vc (m/min)		
			Zugfestigkeit Tensile strength	Inhalt/Härte Content/ Hardness			ae = 100% D1 ap = 1 x D1	ae = 15% D1 ap = L1 max.	ae = 5% D1 ap = L1 max.
P1	Allg. Bau-, Einsatzstähle General construction steels	S235JR (RST37-2), E295 (St 50-2), C45	1.0038, 1.0050, 1.0503	≤ 800 N/mm ²	bis 25 HRC up to 25 HRC	45°	255 – 275	320 – 340	400 – 420
P2	Werkzeug/ Vergütungsstähle Heat treated steels	X38CrMoV5-3, X153CrMoV12, X100CrMoV5, 42CrMo4	1.2367, 1.2379, 1.2363, 1.7225	> 800 N/mm ²	bis 45 HRC up to 45 HRC	30°	190 – 210	220 – 240	290 – 310
M1	Rostfreie Stähle Stainless steels	X8CrNiS18-9, X5CrNi18-10, X46Cr13	1.4305, 1.4301, 1.4034	≤ 650 N/mm ²		10°	95 – 110	115 – 135	150 – 170
M2	Rostfreie Stähle Stainless steels	X6CrNiMoTi17-12-2, X2CrNiMo17-12-2, X4CrNiMo16-5-1	1.4571, 1.4404, 1.4418	> 650 N/mm ²		5°	75 – 90	95 – 105	110 – 130
K1	Gusseisen Cast iron	EN-GJL200 (GG20), EN- GJLZ (GG40), EN- GJS-400-15 (GGG40)	0.6020, 0.6040, 0.7040	≤ 450 N/mm ²		45°	160 – 180	180 – 200	210 – 230
K2	Gusseisen Cast iron	EN-GJS-600-3 (GGG60) EN-GJS-700-2 (GGG70)	0.7060, 0.7070	> 450 N/mm ²		20°	130 – 150	150 – 170	180 – 200
S1	Titan & Titanlegierungen Titanium & titanium alloys	TiAl6V4	3.7165			10°	50 – 60	60 – 80	80 – 90
S2	Warmfeste Legierungen High Temp alloys	Inconel; NIMONIC		800 – 1700 N/ mm ²		5°	30 – 40	30 – 40	30 – 40
N1	Alu-Knetlegierungen Wrought aluminum alloys	AlMg1	3.3315		Si < 9%	30°	470 – 490	600 – 630	780 – 820
N2	Alu-Gusslegierungen Aluminum cast alloys	G-Alsi12	3.2581		Si > 9%	30°	340 – 360	420 – 440	540 – 580
H1	Gehärtete Stähle Hardened steels				45 – 55 HRC	10°	40 – 60	60 – 80	60 – 80

Schnittdaten dienen als Richtwerte und müssen dem Bearbeitungsumfeld angepasst werden.

Beim Bohren wird Entspannen je nach Werkstoff, bei 0,5 – 1 x D empfohlen.

Cutting data are reference values and need to be adjusted according to the application area.

Chip removal recommended for drilling depth 0,5 – 1 x D.

Vorschubtable f_z (mm/Zahn) abhängig von D1 und Schnittbreite ae / Feed per tooth (mm/tooth) in relation with D1 and cutting width ae

	∅ 10	∅ 12	∅ 16	∅ 20
f _z	0,03 – 0,09	0,03 – 0,10	0,04 – 0,12	0,05 – 0,13

Schnittdaten Basis zylindrische Verlängerung kurz, Schnittdaten bei längeren Auskragungen anpassen.

Cutting data is based on cylindrical extensions short, cutting data for long overhang need to be adjusted.

F2004MN – DUO-LOCK® HAIMER MILL ECKENRADIUS/CORNER RADIUS

Technische Daten und Produkteigenschaften/Technical data and Product characteristics



Eigenschaften Characteristics	Anwendung Application	Kühlung Coolant

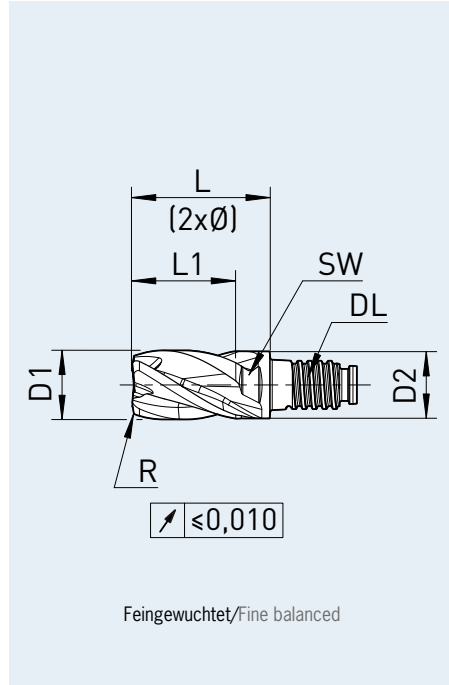

Material – Merkmale/Material – characteristics

Hauptmaterial
Main Material



auch geeignet für
also suitable for

- Halsabsatz für längere Eingriffstiefe
- Zentrumschneide
- Ungleiche Schneidenteilung
- Beste Längenwiederholgenauigkeit

- Neck for higher cutting depth
- Center cutting
- Unequal cutting edge
- Best length repeatability

Artikel-Code Article-Code	Qualität Quality	Duo-Lock Größe Size	D1 (f9) D1 (f9) [mm]	Schneidecke Cutting edge	Größe Size [mm]	L1 max. L1 max. [mm]	L L [mm]	D2 D2 [mm]	SW AF [mm]	Drehmoment Torque [N/m]
DL10F2004MN1000R0.30..	DA	DL10	10,00	R	0,3	15	20	9,6	SW8	20
DL10F2004MN1000R0.50..	DA	DL10	10,00	R	0,5	15	20	9,6	SW8	20
DL10F2004MN1000R0.80..	DA	DL10	10,00	R	0,8	15	20	9,6	SW8	20
DL10F2004MN1000R1.00..	DA	DL10	10,00	R	1,0	15	20	9,6	SW8	20
DL10F2004MN1000R1.50..	DA	DL10	10,00	R	1,5	15	20	9,6	SW8	20
DL10F2004MN1000R2.00..	DA	DL10	10,00	R	2,0	15	20	9,6	SW8	20
DL10F2004MN1000R2.50..	DA	DL10	10,00	R	2,5	15	20	9,6	SW8	20
DL12F2004MN1200R0.50..	DA	DL12	12,00	R	0,5	18	24	11,5	SW9,5	30
DL12F2004MN1200R0.80..	DA	DL12	12,00	R	0,8	18	24	11,5	SW9,5	30
DL12F2004MN1200R1.00..	DA	DL12	12,00	R	1,0	18	24	11,5	SW9,5	30
DL12F2004MN1200R2.00..	DA	DL12	12,00	R	2,0	18	24	11,5	SW9,5	30
DL12F2004MN1200R2.50..	DA	DL12	12,00	R	2,5	18	24	11,5	SW9,5	30
DL12F2004MN1200R3.00..	DA	DL12	12,00	R	3,0	18	24	11,5	SW9,5	30
DL12F2004MN1200R4.00..	DA	DL12	12,00	R	4,0	18	24	11,5	SW9,5	30

⇒ Weitere Artikel siehe nächste Seite/Turn page for more articles

Bestellnummer = Artikel-Code + Qualität.
Order No. = Article Code + Quality.

F2004MN – DUO-LOCK® HAIMER MILL ECKENRADIUS/CORNER RADIUS

Schnittdaten/Cutting data

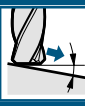
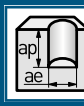
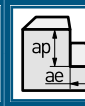
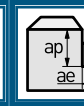
HAIMER Werkstoff Gruppen HAIMER Material groups	Beispiel Werkstoffe Example material	Werkstoffnr. Material no.	Werkstoff Information Material information		Schnittbreite/Cutting width    	Rampe Ramping	Schnittgeschwindigkeit Vc (m/min) Cutting speed Vc (m/min)		
			Zugfestigkeit Tensile strength	Inhalt/Härte Content/ Hardness			ae = 100% D1 ap = 1 x D1	ae = 15% D1 ap = L1 max.	ae = 5% D1 ap = L1 max.
P1	Allg. Bau-, Einsatzstähle General construction steels	S235JR (RST37-2), E295 (St 50-2), C45	1.0038, 1.0050, 1.0503	≤ 800 N/mm ²	bis 25 HRC up to 25 HRC	45°	255 – 275	320 – 340	400 – 420
P2	Werkzeug/ Vergütungsstähle Heat treated steels	X38CrMoV5-3, X153CrMoV12, X100CrMoV5, 42CrMo4	1.2367, 1.2379, 1.2363, 1.7225	> 800 N/mm ²	bis 45 HRC up to 45 HRC	30°	190 – 210	220 – 240	290 – 310
M1	Rostfreie Stähle Stainless steels	X8CrNiS18-9, X5CrNi18-10, X46Cr13	1.4305, 1.4301, 1.4034	≤ 650 N/mm ²		10°	95 – 110	115 – 135	150 – 170
M2	Rostfreie Stähle Stainless steels	X6CrNiMoTi17-12-2, X2CrNiMo17-12-2, X4CrNiMo16-5-1	1.4571, 1.4404, 1.4418	> 650 N/mm ²		5°	75 – 90	95 – 105	110 – 130
K1	Gusseisen Cast iron	EN-GJL200 (GG20), EN- GJLZ (GG40), EN- GJS-400-15 (GGG40)	0.6020, 0.6040, 0.7040	≤ 450 N/mm ²		45°	160 – 180	180 – 200	210 – 230
K2	Gusseisen Cast iron	EN-GJS-600-3 (GGG60) EN-GJS-700-2 (GGG70)	0.7060, 0.7070	> 450 N/mm ²		20°	130 – 150	150 – 170	180 – 200
S1	Titan & Titanlegierungen Titanium & titanium alloys	TiAl6V4	3.7165			10°	50 – 60	60 – 80	80 – 90
S2	Warmfeste Legierungen High Temp alloys	Inconel; NIMONIC		800 – 1700 N/ mm ²		5°	30 – 40	30 – 40	30 – 40
N1	Alu-Knetlegierungen Wrought aluminum alloys	AlMg1	3.3315		Si < 9%	30°	470 – 490	600 – 630	780 – 820
N2	Alu-Gusslegierungen Aluminum cast alloys	G-Alsi12	3.2581		Si > 9%	30°	340 – 360	420 – 440	540 – 580
H1	Gehärtete Stähle Hardened steels				45 – 55 HRC	10°	40 – 60	60 – 80	60 – 80

Schnittdaten dienen als Richtwerte und müssen dem Bearbeitungsumfeld angepasst werden.

Beim Bohren wird Entspannen je nach Werkstoff, bei 0,5 – 1 x D empfohlen.

Cutting data are reference values and need to be adjusted according to the application area.

Chip removal recommended for drilling depth 0,5 – 1 x D.

Vorschubtable f_z (mm/Zahn) abhängig von D1 und Schnittbreite ae / Feed per tooth (mm/tooth) in relation with D1 and cutting width ae

	∅ 10	∅ 12	∅ 16	∅ 20
f _z	0,03 – 0,09	0,03 – 0,10	0,04 – 0,12	0,05 – 0,13

Schnittdaten Basis zylindrische Verlängerung kurz, Schnittdaten bei längeren Auskragungen anpassen.

Cutting data is based on cylindrical extensions short, cutting data for long overhang need to be adjusted.

F2004MN – DUO-LOCK® HAIMER MILL ECKENRADIUS/CORNER RADIUS

Technische Daten und Produkteigenschaften/Technical data and Product characteristics



Eigenschaften Characteristics	Anwendung Application	Kühlung Coolant

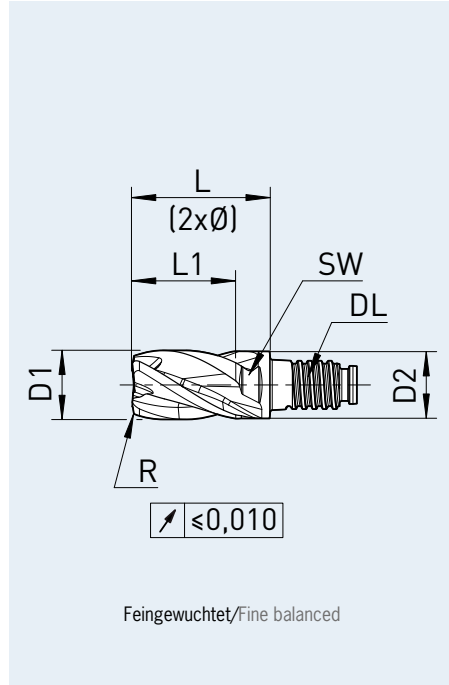

Material – Merkmale/Material – characteristics

Hauptmaterial
Main Material



auch geeignet für
also suitable for

- Halsabsatz für längere Eingriffstiefe
- Zentrumschneide
- Ungleiche Schneidenteilung
- Beste Längenwiederholgenauigkeit

- Neck for higher cutting depth
- Center cutting
- Unequal cutting edge
- Best length repeatability

Artikel-Code Article-Code	Qualität Quality	Duo-Lock Größe Size	D1 (f9) D1 (f9) [mm]	Schneidecke Cutting edge	Größe Size [mm]	L1 max. L1 max. [mm]	L L [mm]	D2 D2 [mm]	SW AF [mm]	Drehmoment Torque [N/m]
DL16F2004MN1600R0.50..	DA	DL16	16,00	R	0,5	24	32	15,5	SW13	60
DL16F2004MN1600R0.80..	DA	DL16	16,00	R	0,8	24	32	15,5	SW13	60
DL16F2004MN1600R1.00..	DA	DL16	16,00	R	1,0	24	32	15,5	SW13	60
DL16F2004MN1600R2.00..	DA	DL16	16,00	R	2,0	24	32	15,5	SW13	60
DL16F2004MN1600R2.50..	DA	DL16	16,00	R	2,5	24	32	15,5	SW13	60
DL16F2004MN1600R3.00..	DA	DL16	16,00	R	3,0	24	32	15,5	SW13	60
DL16F2004MN1600R4.00..	DA	DL16	16,00	R	4,0	24	32	15,5	SW13	60
DL20F2004MN2000R0.50..	DA	DL20	20,00	R	0,5	30	40	19,3	SW16	80
DL20F2004MN2000R0.80..	DA	DL20	20,00	R	0,8	30	40	19,3	SW16	80
DL20F2004MN2000R2.00..	DA	DL20	20,00	R	2,0	30	40	19,3	SW16	80
DL20F2004MN2000R2.50..	DA	DL20	20,00	R	2,5	30	40	19,3	SW16	80
DL20F2004MN2000R3.00..	DA	DL20	20,00	R	3,0	30	40	19,3	SW16	80
DL20F2004MN2000R4.00..	DA	DL20	20,00	R	4,0	30	40	19,3	SW16	80

Bestellnummer = Artikel-Code + Qualität.
Order No. = Article Code + Quality.

F2004UK – DUO-LOCK® HAIMER MILL FASE/CHAMFER

Schnittdaten/Cutting data

HAIMER Werkstoff Gruppen HAIMER Material groups	Beispiel Werkstoffe Example material	Werkstoffnr. Material no.	Werkstoff Information Material information		Schnittbreite/Cutting width	Schnittgeschwindigkeit Vc (m/min) Cutting speed Vc (m/min)			
			Zugfestigkeit Tensile strength	Inhalt/Härte Content/ Hardness		Rampe Ramping	Schnittgeschwindigkeit Vc (m/min) Cutting speed Vc (m/min)		
P1	Allg. Bau-, Einsatzstähle General construction steels	S235JR (RST37-2), E295 (St 50-2), C45	1.0038, 1.0050, 1.0503	≤ 800 N/mm ²	bis 25 HRC up to 25 HRC	45°	255 – 275	320 – 340	400 – 420
P2	Werkzeug/ Vergütungsstähle Heat treated steels	X38CrMoV5-3, X153CrMoV12, X100CrMoV5, 42CrMo4	1.2367, 1.2379, 1.2363, 1.7225	> 800 N/mm ²	bis 45 HRC up to 45 HRC	30°	190 – 210	220 – 240	290 – 310
M1	Rostfreie Stähle Stainless steels	X8CrNiS18-9, X5CrNi18-10, X46Cr13	1.4305, 1.4301, 1.4034	≤ 650 N/mm ²		10°	95 – 110	115 – 135	150 – 170
M2	Rostfreie Stähle Stainless steels	X6CrNiMoTi17-12-2, X2CrNiMo17-12-2, X4CrNiMo16-5-1	1.4571, 1.4404, 1.4418	> 650 N/mm ²		5°	75 – 90	95 – 105	110 – 130
K1	Gusseisen Cast iron	EN-GJL200 (GG20), EN- GJLZ (GG40), EN- GJS-400-15 (GGG40)	0.6020, 0.6040, 0.7040	≤ 450 N/mm ²		45°	160 – 180	180 – 200	210 – 230
K2	Gusseisen Cast iron	EN-GJS-600-3 (GGG60) EN-GJS-700-2 (GGG70)	0.7060, 0.7070	> 450 N/mm ²		20°	130 – 150	150 – 170	180 – 200
S1	Titan & Titanlegierungen Titanium & titanium alloys	TiAl6V4	3.7165			10°	50 – 60	60 – 80	80 – 90
S2	Warmfeste Legierungen High Temp alloys	Inconel; NIMONIC		800 – 1700 N/ mm ²		5°	30 – 40	30 – 40	30 – 40
N1	Alu-Knetlegierungen Wrought aluminum alloys	AlMg1	3.3315		Si < 9%	30°	470 – 490	600 – 630	780 – 820
N2	Alu-Gusslegierungen Aluminum cast alloys	G-Alsi12	3.2581		Si > 9%	30°	340 – 360	420 – 440	540 – 580
H1	Gehärtete Stähle Hardened steels				45 – 55 HRC	10°	40 – 60	60 – 80	60 – 80

Schnittdaten dienen als Richtwerte und müssen dem Bearbeitungsumfeld angepasst werden.
Beim Bohren wird Entspannen je nach Werkstoff, bei 0,5 – 1 x D empfohlen.
Cutting data are reference values and need to be adjusted according to the application area.
Chip removal recommended for drilling depth 0,5 – 1 x D.

Vorschubtable f_z (mm/Zahn) abhängig von D1 und Schnittbreite ae / Feed per tooth (mm/tooth) in relation with D1 and cutting width ae

	∅ 10	∅ 12	∅ 16	∅ 20	∅ 25	∅ 32
f _z	0,03 – 0,09	0,03 – 0,10	0,04 – 0,12	0,05 – 0,13	0,06 – 0,17	0,07 – 0,20

Schnittdaten Basis zylindrische Verlängerung kurz, Schnittdaten bei längeren Auskragungen anpassen.
Cutting data is based on cylindrical extensions short, cutting data for long overhang need to be adjusted.

F2004UK – DUO-LOCK® HAIMER MILL FASE/CHAMFER

Technische Daten und Produkteigenschaften/Technical data and Product characteristics



Eigenschaften Characteristics	Anwendung Application	Kühlung Coolant
0.75 x Ø		
45°		Air
Z=4		
31° 33°		

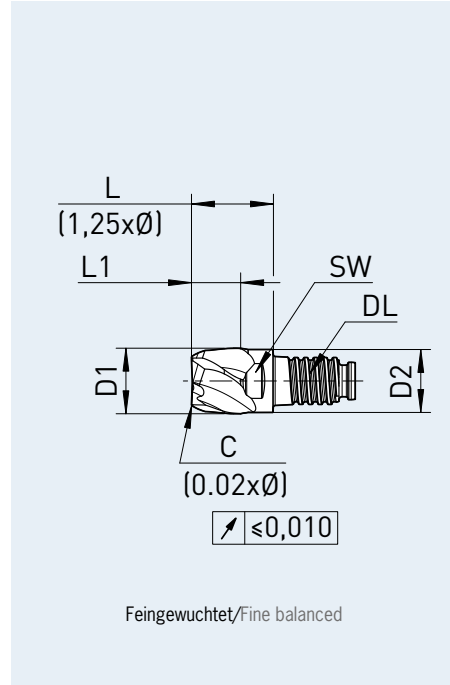

Material – Merkmale/Material – characteristics

Hauptmaterial
Main Material



auch geeignet für
also suitable for

- Halsabsatz für längere Eingriffstiefe
- Zentrumschneide
- Ungleiche Schneidenteilung
- Beste Längenwiederholgenauigkeit

- Neck for higher cutting depth
- Center cutting
- Unequal cutting edge
- Best length repeatability

Artikel-Code Article-Code	Qualität Quality	Duo-Lock Größe Size	D1 (f9) D1 (f9) [mm]	Schneidecke Cutting edge	Größe Size [mm]	L1 max. L1 max. [mm]	L L [mm]	D2 D2 [mm]	SW AF [mm]	Drehmoment Torque [N/m]
DL10F2004UK1000C..	DA	DL10	10,00	C	0,20	7,5	12,5	9,6	SW8	20
DL12F2004UK1200C..	DA	DL12	12,00	C	0,24	9	15	11,5	SW9,5	30
DL16F2004UK1600C..	DA	DL16	16,00	C	0,32	12	20	15,5	SW13	60
DL20F2004UK2000C..	DA	DL20	20,00	C	0,40	15	25	19,3	SW16	80
DL25F2004UK2500C..	DA	DL25	25,00	C	0,50	18,75	31,25	24,0	SW21	100
DL32F2004UK3200C..	DA	DL32	32,00	C	0,64	24	40	31,0	SW28	130

Bestellnummer = Artikel-Code + Qualität.
Order No. = Article Code + Quality.

F2006/08/00MN – DUO-LOCK® HAIMER MILL FASE SCHLICHTEN/CHAMFER FINISHING

Schnittdaten/Cutting data

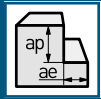
HAIMER Werkstoff Gruppen HAIMER Material groups	Beispiel Werkstoffe Example material	Werkstoffnr. Material no.	Werkstoff Information Material information		Schnittbreite Cutting width  ae = 5% D1 ap = L1 max.	
			Zugfestigkeit Tensile strength	Inhalt/Härte Content/ Hardness		Schnittgeschwindigkeit Vc (m/min) Cutting speed Vc (m/min)
P1	Allg. Bau-, Einsatzstähle General construction steels	S235JR (RST37-2), E295 (St 50-2), C45	1.0038, 1.0050, 1.0503	≤ 800 N/mm ²	bis 25 HRC up to 25 HRC	220 – 280
P2	Werkzeug-/Vergütungsstähle Heat treated steels	X38CrMoV5-3, X153CrMoV12, X100CrMoV5, 42CrMo4	1.2367, 1.2379, 1.2363, 1.7225	> 800 N/mm ²	bis 45 HRC up to 45 HRC	160 – 200
M1	Rostfreie Stähle Stainless steels	X8CrNiS18-9, X5CrNi18-10, X46Cr13	1.4305, 1.4301, 1.4034	≤ 650 N/mm ²		120 – 160
M2	Rostfreie Stähle Stainless steels	X6CrNiMoTi17-12-2, X2CrNiMo17-12-2, X4CrNiMo16-5-1	1.4571, 1.4404, 1.4418	> 650 N/mm ²		90 – 120
K1	Gusseisen Cast iron	EN-GJL200 (GG20), EN-GJLZ (GG40), EN-GJS-400-15 (GGG40)	0.6020, 0.6040, 0.7040	≤ 450 N/mm ²		180 – 240
K2	Gusseisen Cast iron	EN-GJS-600-3 (GGG60), EN-GJS-700-2 (GGG70)	0.7060, 0.7070	> 450 N/mm ²		160 – 220
S1	Titan & Titanlegierungen Titanium & titanium alloys	TiAl6V4	3.7165			40 – 80
S2	Warmfeste Legierungen High Temp alloys	Inconel; NIMONIC		800 – 1700 N/mm ²		30 – 40
N1	Alu-Knetlegierungen Wrought aluminum alloys	AlMg1	3.3315		Si < 9%	500 – 900
N2	Alu-Gusslegierungen Aluminum cast alloys	G-Alsi12	3.2581		Si > 9%	120 – 350
H1	Gehärtete Stähle Hardened steels				45 – 55 HRC	60 – 80

Schnittdaten dienen als Richtwerte und müssen dem Bearbeitungsumfeld angepasst werden.
 Cutting data are reference values and need to be adjusted according to the application area.

Vorschubtable f_z (mm/Zahn) abhängig von D1 und Schnittbreite ae /Feed per tooth (mm/tooth) in relation with D1 and cutting width ae

ae 5%	ø 10	ø 12	ø 16	ø 20
f _z	0,03 – 0,09	0,03 – 0,10	0,04 – 0,12	0,05 – 0,13

Schnittdaten Basis zylindrische Verlängerung kurz, Schnittdaten bei längeren Auskragungen anpassen.
 Cutting data is based on cylindrical extensions short, cutting data for long overhang need to be adjusted.

F2006/08/00MN – DUO-LOCK® HAIMER MILL FASE SCHLICHTEN/CHAMFER FINISHING

Technische Daten und Produkteigenschaften/Technical data and Product characteristics



Eigenschaften Characteristics	Anwendung Application	Kühlung Coolant
1.5 x Ø		
45°		Air
Z=6/8/10		
35°		

Feingewuchtet/Fine balanced
* nicht zentrumschneidender Durchmesser
* diameter not center cutting

Material – Merkmale/Material – characteristics

Haupteinsatz
Main Material

auch geeignet für
also suitable for

- Halsabsatz für längere Eingriffstiefe
- Ungleiche Schneidenteilung
- Beste Längenwiederholgenauigkeit

- Neck for higher cutting depth
- Unequal cutting edge
- Best length repeatability



Artikel-Code Article-Code	Qualität Quality	Duo-Lock Größe Size	D1 (f9) D1 (f9) [mm]	Schneidecke Cutting edge	Zähne- zahl No. teeth	Größe Size [mm]	L1 max. L1 max. [mm]	L L [mm]	D2 D2 [mm]	SW AF [mm]	Drehmoment Torque [N/m]
DL10F2006MN1000C..	DA	DL10	10,00	C	6	0,2	15	20	9,6	SW8	20
DL12F2006MN1200C..	DA	DL12	12,00	C	6	0,24	18	24	11,5	SW9,5	30
DL16F2008MN1600C..	DA	DL16	16,00	C	8	0,32	24	32	15,5	SW13	60
DL20F2000MN2000C..	DA	DL20	20,00	C	10	0,4	30	40	19,3	SW16	80

Bestellnummer = Artikel-Code + Qualität.
Order No. = Article Code + Quality.

F2006/08/00MN – DUO-LOCK® HAIMER MILL ECKENRADIUS SCHLICHTEN/CORNER RADIUS FINISHING

Schnittdaten/Cutting data

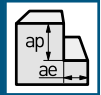
HAIMER Werkstoff Gruppen HAIMER Material groups	Beispiel Werkstoffe Example material	Werkstoffnr. Material no.	Werkstoff Information Material information		Schnittbreite Cutting width  ae = 5% D1 ap = L1 max.	
			Zugfestigkeit Tensile strength	Inhalt/Härte Content/ Hardness		
P1	Allg. Bau-, Einsatzstähle General construction steels	S235JR (RST37-2), E295 (St 50-2), C45	1.0038, 1.0050, 1.0503	≤ 800 N/mm ²	bis 25 HRC up to 25 HRC	220 – 280
P2	Werkzeug/ Vergütungsstähle Heat treated steels	X38CrMoV5-3, X153CrMoV12, X100CrMoV5, 42CrMo4	1.2367, 1.2379, 1.2363, 1.7225	> 800 N/mm ²	bis 45 HRC up to 45 HRC	160 – 200
M1	Rostfreie Stähle Stainless steels	X8CrNiS18-9, X5CrNi18-10, X46Cr13	1.4305, 1.4301, 1.4034	≤ 650 N/mm ²		120 – 160
M2	Rostfreie Stähle Stainless steels	X6CrNiMoTi17-12-2, X2CrNiMo17-12-2, X4CrNiMo16-5-1	1.4571, 1.4404, 1.4418	> 650 N/mm ²		90 – 120
K1	Gusseisen Cast iron	EN-GJL200 (GG20), EN-GJLZ (GG40), EN- GJS-400-15 (GGG40)	0.6020, 0.6040, 0.7040	≤ 450 N/mm ²		180 – 240
K2	Gusseisen Cast iron	EN-GJS-600-3 (GGG60), EN-GJS-700-2 (GGG70)	0.7060, 0.7070	> 450 N/mm ²		160 – 220
S1	Titan & Titanlegierungen Titanium & titanium alloys	TiAl6V4	3.7165			40 – 80
S2	Warmfeste Legierungen High Temp alloys	Inconel; NIMONIC		800 – 1700 N/ mm ²		30 – 40
N1	Alu-Knetlegierungen Wrought aluminum alloys	AlMg1	3.3315		Si < 9%	500 – 900
N2	Alu-Gusslegierungen Aluminum cast alloys	G-Alsi12	3.2581		Si > 9%	120 – 350
H1	Gehärtete Stähle Hardened steels				45 – 55 HRC	60 – 80

Schnittdaten dienen als Richtwerte und müssen dem Bearbeitungsumfeld angepasst werden.
 Cutting data are reference values and need to be adjusted according to the application area.

Vorschubtable f_z (mm/Zahn) abhängig von D1 und Schnittbreite ae /Feed per tooth (mm/tooth) in relation with D1 and cutting width ae

ae 5%	ø 10	ø 12	ø 16	ø 20
f _z	0,03 – 0,09	0,03 – 0,10	0,04 – 0,12	0,05 – 0,13

Schnittdaten Basis zylindrische Verlängerung kurz, Schnittdaten bei längeren Auskragungen anpassen.
 Cutting data is based on cylindrical extensions short, cutting data for long overhang need to be adjusted.

F2006/08/00MN – DUO-LOCK® HAIMER MILL ECKENRADIUS SCHLICHTEN/CORNER RADIUS FINISHING

Technische Daten und Produkteigenschaften/Technical data and Product characteristics



Eigenschaften Characteristics	Anwendung Application	Kühlung Coolant

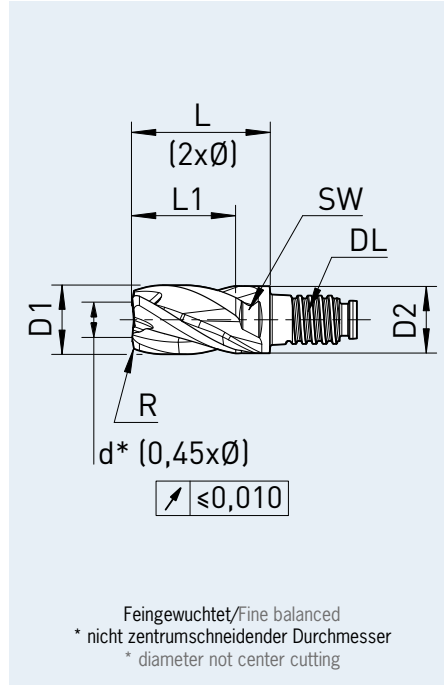

Material – Merkmale/Material – characteristics

Haupteinsatz
Main Material



auch geeignet für
also suitable for

- Halsabsatz für längere Eingriffstiefe
- Ungleiche Schneidenteilung
- Beste Längenwiederholgenauigkeit

- Neck for higher cutting depth
- Unequal cutting edge
- Best length repeatability

Artikel-Code Article-Code	Qualität Quality	Duo-LOCK Größe Size	D1 (f9) D1 (f9) [mm]	Schneidecke Cutting edge	Zähne- zahl No. teeth	Größe Size [mm]	L1 max. L1 max. [mm]	L L [mm]	D2 D2 [mm]	SW AF [mm]	Drehmoment Torque [N/m]
DL10F2006MN1000R0.50..	DA	DL10	10,00	R	6	0,50	15	20	9,6	SW8	20
DL10F2006MN1000R1.00..	DA	DL10	10,00	R	6	1,00	15	20	9,6	SW8	20
DL10F2006MN1000R1.50..	DA	DL10	10,00	R	6	1,50	15	20	9,6	SW8	20
DL10F2006MN1000R2.00..	DA	DL10	10,00	R	6	2,00	15	20	9,6	SW8	20
DL12F2006MN1200R0.50..	DA	DL12	12,00	R	6	0,50	18	24	11,5	SW9,5	30
DL12F2006MN1200R1.00..	DA	DL12	12,00	R	6	1,00	18	24	11,5	SW9,5	30
DL12F2006MN1200R2.00..	DA	DL12	12,00	R	6	2,00	18	24	11,5	SW9,5	30
DL16F2008MN1600R0.50..	DA	DL16	16,00	R	8	0,50	24	32	15,5	SW13	60
DL16F2008MN1600R1.00..	DA	DL16	16,00	R	8	1,00	24	32	15,5	SW13	60
DL16F2008MN1600R2.00..	DA	DL16	16,00	R	8	2,00	24	32	15,5	SW13	60
DL16F2008MN1600R4.00..	DA	DL16	16,00	R	8	4,00	24	32	15,5	SW13	60
DL20F2000MN2000R0.50..	DA	DL20	20,00	R	10	0,50	30	40	19,3	SW16	80
DL20F2000MN2000R2.00..	DA	DL20	20,00	R	10	2,00	30	40	19,3	SW16	80
DL20F2000MN2000R4.00..	DA	DL20	20,00	R	10	4,00	30	40	19,3	SW16	80

Bestellnummer = Artikel-Code + Qualität.
Order No. = Article Code + Quality.

F2006/08/00UK – DUO-LOCK® HAIMER MILL FASE SCHLICHTEN/CHAMFER FINISHING

Schnittdaten/Cutting data

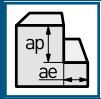
HAIMER Werkstoff Gruppen HAIMER Material groups	Beispiel Werkstoffe Example material	Werkstoffnr. Material no.	Werkstoff Information Material information		Schnittbreite Cutting width  ae = 5% D1 ap = L1 max.	
			Zugfestigkeit Tensile strength	Inhalt/Härte Content/ Hardness		
P1	Allg. Bau-, Einsatzstähle General construction steels	S235JR (RST37-2), E295 (St 50-2), C45	1.0038, 1.0050, 1.0503	≤ 800 N/mm ²	bis 25 HRC up to 25 HRC	220 – 280
P2	Werkzeug/ Vergütungsstähle Heat treated steels	X38CrMoV5-3, X153CrMoV12, X100CrMoV5, 42CrMo4	1.2367, 1.2379, 1.2363, 1.7225	> 800 N/mm ²	bis 45 HRC up to 45 HRC	160 – 200
M1	Rostfreie Stähle Stainless steels	X8CrNiS18-9, X5CrNi18-10, X46Cr13	1.4305, 1.4301, 1.4034	≤ 650 N/mm ²		120 – 160
M2	Rostfreie Stähle Stainless steels	X6CrNiMoTi17-12-2, X2CrNiMo17-12-2, X4CrNiMo16-5-1	1.4571, 1.4404, 1.4418	> 650 N/mm ²		90 – 120
K1	Gusseisen Cast iron	EN-GJL200 (GG20), EN-GJLZ (GG40), EN-GJS-400-15 (GGG40)	0.6020, 0.6040, 0.7040	≤ 450 N/mm ²		180 – 240
K2	Gusseisen Cast iron	EN-GJS-600-3 (GGG60), EN-GJS-700-2 (GGG70)	0.7060, 0.7070	> 450 N/mm ²		160 – 220
S1	Titan & Titanlegierungen Titanium & titanium alloys	TiAl6V4	3.7165			40 – 80
S2	Warmfeste Legierungen High Temp alloys	Inconel; NIMONIC		800 – 1700 N/mm ²		30 – 40
N1	Alu-Knetlegierungen Wrought aluminum alloys	AlMg1	3.3315		Si < 9%	500 – 900
N2	Alu-Gusslegierungen Aluminum cast alloys	G-Alsi12	3.2581		Si > 9%	120 – 350
H1	Gehärtete Stähle Hardened steels				45 – 55 HRC	60 – 80

Schnittdaten dienen als Richtwerte und müssen dem Bearbeitungsumfeld angepasst werden.
 Cutting data are reference values and need to be adjusted according to the application area.

Vorschubtablette fz (mm/Zahn) abhängig von D1 und Schnittbreite ae /Feed per tooth (mm/tooth) in relation with D1 and cutting width ae

ae 5%	ø 10	ø 12	ø 16	ø 20
fz	0,03 – 0,09	0,03 – 0,10	0,04 – 0,12	0,05 – 0,13

Schnittdaten Basis zylindrische Verlängerung kurz, Schnittdaten bei längeren Auskrägungen anpassen.
 Cutting data is based on cylindrical extensions short, cutting data for long overhang need to be adjusted.

F2006/08/00UK – DUO-LOCK® HAIMER MILL FASE SCHLICHTEN/CHAMFER FINISHING

Technische Daten und Produkteigenschaften/Technical data and Product characteristics



Eigenschaften Characteristics

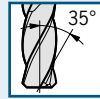
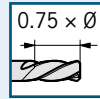

Anwendung Application

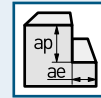
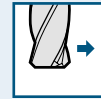

Kühlung Coolant

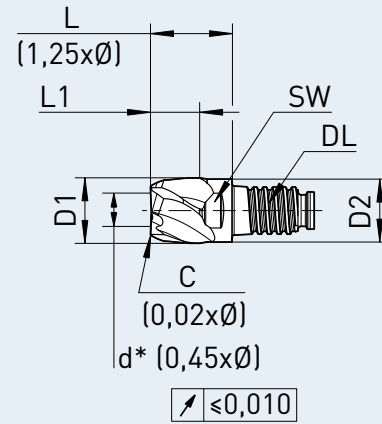

Feingewuchtet/Fine balanced
* nicht zentrumschneidender Durchmesser
* diameter not center cutting

Material – Merkmale/Material – characteristics

Haupteinsatz
Main Material



auch geeignet für
also suitable for

- Halsabsatz für längere Eingriffstiefe
- Ungleiche Schneidenteilung
- Beste Längenwiederholgenauigkeit

- Neck for higher cutting depth
- Unequal cutting edge
- Best length repeatability

Artikel-Code Article-Code	Qualität Quality	Duo-Lock Größe Size	D1 (f9) D1 (f9) [mm]	Schneidecke Cutting edge	Zähne- zahl No. teeth	Größe Size [mm]	L1 max. L1 max. [mm]	L L [mm]	D2 D2 [mm]	SW AF [mm]	Drehmoment Torque [N/m]
DL10F2006UK1000C..	DA	DL10	10,00	C	6	0,2	7,5	12,5	9,6	SW8	20
DL12F2006UK1200C..	DA	DL12	12,00	C	6	0,24	9	15	11,5	SW9,5	30
DL16F2008UK1600C..	DA	DL16	16,00	C	8	0,32	12	20	15,5	SW13	60
DL20F2000UK2000C..	DA	DL20	20,00	C	10	0,4	15	25	19,3	SW16	80

Bestellnummer = Artikel-Code + Qualität.
Order No. = Article Code + Quality.

F2304MN – DUO-LOCK® HAIMER MILL FASE SCHRUPPVERZÄHNUNG/CHAMFER ROUGHING

Schnittdaten/Cutting data

HAIMER Werkstoff Gruppen HAIMER Material groups	Beispiel Werkstoffe Example material	Werkstoff Information Material information				Schruppen Vc (m/min) Roughing Vc (m/min)	Schlichten Vc (m/min) Finishing Vc (m/min)
		DIN DIN	Werkstoffnr. Material no.	Zugfestigkeit Tensile strength	Inhalt/Härte Content/ Hardness		
P1	Allg. Bau-, Einsatzstähle General construction steels	S235JR (RST37-2), E295 (St 50-2), C45	1.0038, 1.0050, 1.0503	≤ 800 N/mm ²	bis 25 HRC up to 25 HRC	160 – 220	220 – 280
P2	Werkzeug/ Vergütungsstähle Heat treated steels	X38CrMoV5-3, X153CrMoV12, X100CrMoV5, 42CrMo4	1.2367, 1.2379, 1.2363, 1.7225	> 800 N/mm ²	bis 45 HRC up to 45 HRC	120 – 160	160 – 200
M1	Rostfreie Stähle Stainless steels	X8CrNiS18-9, X5CrNi18-10, X46Cr13	1.4305, 1.4301, 1.4034	≤ 650 N/mm ²		80 – 120	120 – 160
K1	Gusseisen Cast iron	EN-GJL200 (GG20), EN-GJLZ (GG40), EN- GJS-400-15 (GGG40)	0.6020, 0.6040, 0.7040	≤ 450 N/mm ²		120 – 180	180 – 240
K2	Gusseisen Cast iron	EN-GJS-600-3 (GGG60), EN-GJS-700-2 (GGG70)	0.7060, 0.7070	> 450 N/mm ²		80 – 160	160 – 220
S1	Titan & Titanlegierungen Titanium & titanium alloys	TiAl6V4	3.7165			40 – 80	40 – 80
N1	Alu-Knetlegierungen Wrought aluminum alloys	AlMg1	3.3315		Si < 9%	500 – 900	500 – 900
N2	Alu-Gusslegierungen Aluminum cast alloys	G-Alsi12	3.2581		Si > 9%	120 – 350	120 – 350

Schnittdaten dienen als Richtwerte und müssen dem Bearbeitungsumfeld angepasst werden.
 Cutting data are reference values and need to be adjusted according to the application area.

Vorschubtable f _z (mm/Zahn) abhängig von D1 und Schnittbreite a _e / Feed per tooth (mm/tooth) in relation with D1 and cutting width a _e				
	ø 10	ø 12	ø 16	ø 20
f _z	0,03 – 0,09	0,03 – 0,10	0,04 – 0,12	0,05 – 0,13

Schnittdaten Basis zylindrische Verlängerung kurz, Schnittdaten bei längeren Auskragungen anpassen.
 Cutting data is based on cylindrical extensions short, cutting data for long overhang need to be adjusted.

F2304MN – DUO-LOCK® HAIMER MILL FASE SCHRUPPVERZÄHNUNG/CHAMFER ROUGHING

Technische Daten und Produkteigenschaften/Technical data and Product characteristics



Eigenschaften Characteristics	Anwendung Application	Kühlung Coolant

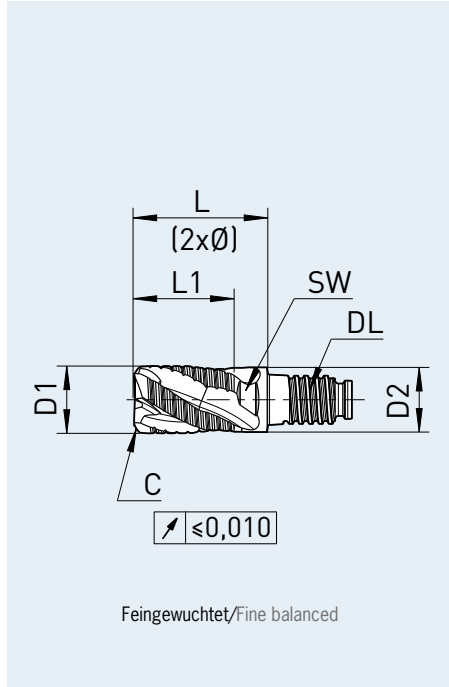

Material – Merkmale/Material – characteristics

Hauptmaterial
Main Material



auch geeignet für
also suitable for



- Halsabsatz für längere Eingriffstiefe
- Neck for higher cutting depth
- Zentrumschneide
- Center cutting
- Ungleiche Schneidenteilung
- Unequal cutting edge
- Beste Längenwiederholgenauigkeit
- Best length repeatability

Artikel-Code Article-Code	Qualität Quality	Duo-Lock Größe Size	D1 (f9) D1 (f9) [mm]	Schneidecke Cutting edge	Größe Size [mm]	L1 max. L1 max. [mm]	L L [mm]	D2 D2 [mm]	SW AF [mm]	Drehmoment Torque [N/m]
DL10F2304MN1000C..	DA	DL10	10,00	C	0,30	15	20	9,6	SW8	20
DL12F2304MN1200C..	DA	DL12	12,00	C	0,30	18	24	11,5	SW9,5	30
DL16F2304MN1600C..	DA	DL16	16,00	C	0,50	24	32	15,5	SW13	60
DL20F2304MN2000C..	DA	DL20	20,00	C	0,60	30	40	19,3	SW16	80

Bestellnummer = Artikel-Code + Qualität.
Order No. = Article Code + Quality.

F2304UK – DUO-LOCK® HAIMER MILL FASE SCHRUPPVERZÄHNUNG/CHAMFER ROUGHING

Schnittdaten/Cutting data

HAIMER Werkstoff Gruppen HAIMER Material groups	Beispiel Werkstoffe Example material	Werkstoffnr. Material no.	Werkstoff Information Material information		Schruppen Vc (m/min) Roughing Vc (m/min)	Schlichten Vc (m/min) Finishing Vc (m/min)	
			Zugfestigkeit Tensile strength	Inhalt/Härte Content/ Hardness			
P1	Allg. Bau-, Einsatzstähle General construction steels	S235JR (RST37-2), E295 (St 50-2), C45	1.0038, 1.0050, 1.0503	≤ 800 N/mm ²	bis 25 HRC up to 25 HRC	160 – 220	220 – 280
P2	Werkzeug-/Vergütungsstähle Heat treated steels	X38CrMoV5-3, X153CrMoV12, X100CrMoV5, 42CrMo4	1.2367, 1.2379, 1.2363, 1.7225	> 800 N/mm ²	bis 45 HRC up to 45 HRC	120 – 160	160 – 200
M1	Rostfreie Stähle Stainless steels	X8CrNiS18-9, X5CrNi18-10, X46Cr13	1.4305, 1.4301, 1.4034	≤ 650 N/mm ²		80 – 120	120 – 160
K1	Gusseisen Cast iron	EN-GJL200 (GG20), EN-GJLZ (GG40), EN-GJS-400-15 (GGG40)	0.6020, 0.6040, 0.7040	≤ 450 N/mm ²		120 – 180	180 – 240
K2	Gusseisen Cast iron	EN-GJS-600-3 (GGG60), EN-GJS-700-2 (GGG70)	0.7060, 0.7070	> 450 N/mm ²		80 – 160	160 – 220
S1	Titan & Titanlegierungen Titanium & titanium alloys	TiAl6V4	3.7165			40 – 80	40 – 80
N1	Alu-Knetlegierungen Wrought aluminum alloys	AlMg1	3.3315		Si < 9%	500 – 900	500 – 900
N2	Alu-Gusslegierungen Aluminum cast alloys	G-Alsi12	3.2581		Si > 9%	120 – 350	120 – 350

Schnittdaten dienen als Richtwerte und müssen dem Bearbeitungsumfeld angepasst werden.
Cutting data are reference values and need to be adjusted according to the application area.

Vorschubtable f _z (mm/Zahn) abhängig von D1 und Schnittbreite a _e / Feed per tooth (mm/tooth) in relation with D1 and cutting width a _e				
	ø 10	ø 12	ø 16	ø 20
f _z	0,03 – 0,09	0,03 – 0,10	0,04 – 0,12	0,05 – 0,13

Schnittdaten Basis zylindrische Verlängerung kurz, Schnittdaten bei längeren Auskragungen anpassen.
Cutting data is based on cylindrical extensions short, cutting data for long overhang need to be adjusted.

F2304UK – DUO-LOCK® HAIMER MILL FASE SCHRUPPVERZÄHNUNG/CHAMFER ROUGHING

Technische Daten und Produkteigenschaften/Technical data and Product characteristics



Eigenschaften Characteristics	Anwendung Application	Kühlung Coolant

Material – Merkmale/Material – characteristics

Hauptmaterial
Main Material



auch geeignet für
also suitable for



- Halsabsatz für längere Eingriffstiefe
- Zentrumschneide
- Ungleiche Schneidenteilung
- Beste Längenwiederholgenauigkeit
- Neck for higher cutting depth
- Center cutting
- Unequal cutting edge
- Best length repeatability

Artikel-Code Article-Code	Qualität Quality	Duo-Lock Größe Size	D1 (f9) D1 (f9) [mm]	Schneidecke Cutting edge	Größe Size [mm]	L1 max. L1 max. [mm]	L L [mm]	D2 D2 [mm]	SW AF [mm]	Drehmoment Torque [N/m]
DL10F2304UK1000C..	DA	DL10	10,00	C	0,30	7,5	12,5	9,6	SW8	20
DL12F2304UK1200C..	DA	DL12	12,00	C	0,30	9	15	11,5	SW9,5	30
DL16F2304UK1600C..	DA	DL16	16,00	C	0,50	12	20	15,5	SW13	60
DL20F2304UK2000C..	DA	DL20	20,00	C	0,60	15	25	19,3	SW16	80

Bestellnummer = Artikel-Code + Qualität.
Order No. = Article Code + Quality.

F4002MN – DUO-LOCK® HAIMER MILL Alu Series FASE/CHAMFER

Schnittdaten/Cutting data

HAIMER Werkstoff Gruppen HAIMER Material groups	Beispiel Werkstoffe Example material	Werkstoffnr. Material no.	Werkstoff Information Material information		Schruppen Vc (m/min) Roughing Vc (m/min)	Schlichten Vc (m/min) Finishing Vc (m/min)
			Zugfestigkeit Tensile strength	Inhalt/Härte Content/ Hardness		
N1	Alu-Knetlegierungen Wrought aluminum alloys	AlMg1	3.3315		300 – 400	400 – 500
N2	Alu-Gusslegierungen Aluminum cast alloys	G-Alsi12	3.2581			

Schnittdaten dienen als Richtwerte und müssen dem Bearbeitungsumfeld angepasst werden.
Cutting data are reference values and need to be adjusted according to the application area.

Vorschubtabelle fz (mm/Zahn) abhängig von D1 und Schnittbreite ae /Feed per tooth (mm/tooth) in relation with D1 and cutting width ae

	ø 10	ø 12	ø 16	ø 20
fz	0,03 – 0,09	0,03 – 0,10	0,04 – 0,12	0,05 – 0,13

Schnittdaten Basis zylindrische Verlängerung kurz, Schnittdaten bei längeren Auskragungen anpassen.
Cutting data is based on cylindrical extensions short, cutting data for long overhang need to be adjusted.

F4002MN – DUO-LOCK® HAIMER MILL Alu Series FASE/CHAMFER

Technische Daten und Produkteigenschaften/Technical data and Product characteristics



Eigenschaften Characteristics	Anwendung Application	Kühlung Coolant

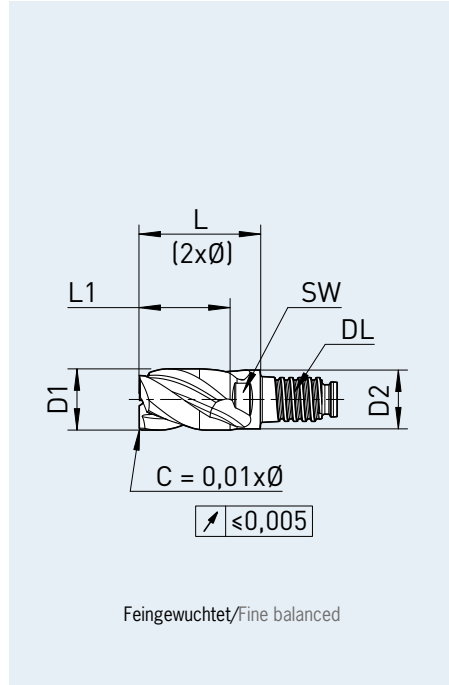

Material – Merkmale/Material – characteristics

Haupteinsatz
Main Material



- Halsabsatz für längere Eingriffstiefe
- Zentrumschneide
- Polierte Span- und Freiflächen
- Beste Längenwiederholgenauigkeit
- Neck for higher cutting depth
- Center cutting
- Polished flute and relief
- Best length repeatability

Artikel-Code Article-Code	Qualität Quality	Duo-Lock Größe Size	D1 (h9) D1 (h9) [mm]	Schneidecke Cutting edge	Größe Size [mm]	L1 max. L1 max. [mm]	L L [mm]	D2 D2 [mm]	SW AF [mm]	Drehmoment Torque [N/m]
DL10F4002MN1000C..	D-	DL10	10,00	C	0,1	15	20	9,6	SW8	20
DL12F4002MN1200C..	D-	DL12	12,00	C	0,12	18	24	11,5	SW9,5	30
DL16F4002MN1600C..	D-	DL16	16,00	C	0,16	24	32	15,5	SW13	60
DL20F4002MN2000C..	D-	DL20	20,00	C	0,2	30	40	19,3	SW16	80

Bestellnummer = Artikel-Code + Qualität.
Order No. = Article Code + Quality.

F4002MN – DUO-LOCK® HAIMER MILL Alu Series FASE/CHAMFER

Schnittdaten/Cutting data

HAIMER Werkstoff Gruppen HAIMER Material groups	Beispiel Werkstoffe Example material	Werkstoffnr. Material no.	Werkstoff Information Material information		Schruppen Vc (m/min) Roughing Vc (m/min)	Schlichten Vc (m/min) Finishing Vc (m/min)
			Zugfestigkeit Tensile strength	Inhalt/Härte Content/ Hardness		
N1	Alu-Knetlegierungen Wrought aluminum alloys	AlMg1	3.3315		300 – 400	400 – 500
N2	Alu-Gusslegierungen Aluminum cast alloys	G-Alsi12	3.2581			

Schnittdaten dienen als Richtwerte und müssen dem Bearbeitungsumfeld angepasst werden.
Cutting data are reference values and need to be adjusted according to the application area.

Vorschubtable f_z (mm/Zahn) abhängig von D1 und Schnittbreite a_e / Feed per tooth (mm/tooth) in relation with D1 and cutting width a_e

	ø 10	ø 12	ø 16	ø 20
f _z	0,03 – 0,09	0,03 – 0,10	0,04 – 0,12	0,05 – 0,13

Schnittdaten Basis zylindrische Verlängerung kurz, Schnittdaten bei längeren Auskragungen anpassen.
Cutting data is based on cylindrical extensions short, cutting data for long overhang need to be adjusted.

F4002MN – DUO-LOCK® HAIMER MILL Alu Series FASE/CHAMFER

Technische Daten und Produkteigenschaften/Technical data and Product characteristics



Eigenschaften Characteristics	Anwendung Application	Kühlung Coolant

Feingewuchtet/Fine balanced

Material – Merkmale/Material – characteristics

Haupteinsatz
Main Material



- Beschichtung für abrasive Werkstoffe
- Halsabsatz für längere Eingriffstiefe
- Zentrumsschneide
- Polierte Span- und Freiflächen
- Beste Längenwiederholgenauigkeit
- Coating for abrasive materials
- Neck for higher cutting depth
- Center cutting
- Polished flute and relief
- Best length repeatability

Artikel-Code Article-Code	Qualität Quality	Duo-Lock Größe Size	D1 (h9) D1 (h9) [mm]	Schneidecke Cutting edge	Größe Size [mm]	L1 max. L1 max. [mm]	L L [mm]	D2 D2 [mm]	SW AF [mm]	Drehmoment Torque [N/m]
DL10F4002MN1000C..	DC	DL10	10,00	C	0,1	15	20	9,6	SW8	20
DL12F4002MN1200C..	DC	DL12	12,00	C	0,12	18	24	11,5	SW9,5	30
DL16F4002MN1600C..	DC	DL16	16,00	C	0,16	24	32	15,5	SW13	60
DL20F4002MN2000C..	DC	DL20	20,00	C	0,2	30	40	19,3	SW16	80

Bestellnummer = Artikel-Code + Qualität.
Order No. = Article Code + Quality.

F4003MN – DUO-LOCK® HAIMER MILL Alu Series FASE/CHAMFER

Schnittdaten/Cutting data

HAIMER Werkstoff Gruppen HAIMER Material groups	Beispiel Werkstoffe Example material	Werkstoff Information Material information			Schruppen Vc (m/min) Roughing Vc (m/min)	Schlichten Vc (m/min) Finishing Vc (m/min)
		DIN DIN	Werkstoffnr. Material no.	Zugfestigkeit Tensile strength		
N1	Alu-Knetlegierungen Wrought aluminum alloys	AlMg1	3.3315		300 – 400	400 – 500
N2	Alu-Gusslegierungen Aluminum cast alloys	G-Alsi12	3.2581			

Schnittdaten dienen als Richtwerte und müssen dem Bearbeitungsumfeld angepasst werden.
 Cutting data are reference values and need to be adjusted according to the application area.

Vorschubtable f_z (mm/Zahn) abhängig von D1 und Schnittbreite a_e / Feed per tooth (mm/tooth) in relation with D1 and cutting width a_e

	ø 10	ø 12	ø 16	ø 20
f _z	0,03 – 0,09	0,03 – 0,10	0,04 – 0,12	0,05 – 0,13

Schnittdaten Basis zylindrische Verlängerung kurz, Schnittdaten bei längeren Auskragungen anpassen.
 Cutting data is based on cylindrical extensions short, cutting data for long overhang need to be adjusted.

F4003MN – DUO-LOCK® HAIMER MILL Alu Series FASE/CHAMFER

Technische Daten und Produkteigenschaften/Technical data and Product characteristics



Eigenschaften Characteristics	Anwendung Application	Kühlung Coolant
1.5 × Ø		
45°	45°	Air
Z=3	ap ae	
41° 42° 43°	ap ae	

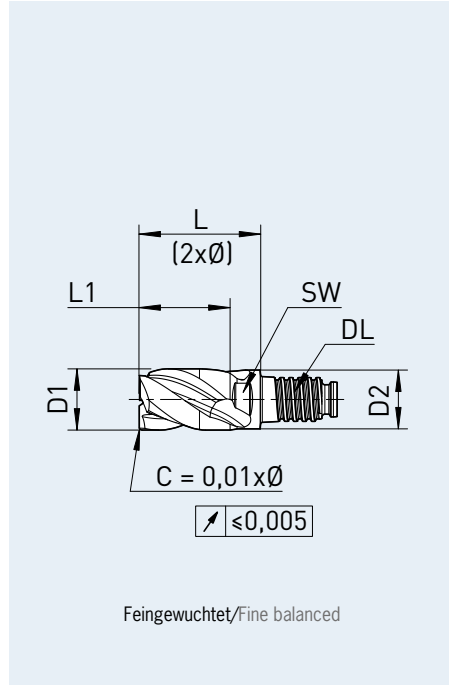

Material – Merkmale/Material – characteristics

Hauptersatz
Main Material



- Halsabsatz für längere Eingriffstiefe
- Zentrumschneide
- Polierte Span- und Freiflächen
- Beste Längenwiederholgenauigkeit
- Neck for higher cutting depth
- Center cutting
- Polished flute and relief
- Best length repeatability

Artikel-Code Article-Code	Qualität Quality	Duo-Lock Größe Size	D1 (h9) D1 (h9) [mm]	Schneidecke Cutting edge	Größe Size [mm]	L1 max. L1 max. [mm]	L L [mm]	D2 D2 [mm]	SW AF [mm]	Drehmoment Torque [N/m]
DL10F4003MN1000C..	D-	DL10	10,00	C	0,1	15	20	9,6	SW8	20
DL12F4003MN1200C..	D-	DL12	12,00	C	0,12	18	24	11,5	SW9,5	30
DL16F4003MN1600C..	D-	DL16	16,00	C	0,16	24	32	15,5	SW13	60
DL20F4003MN2000C..	D-	DL20	20,00	C	0,2	30	40	19,3	SW16	80

Bestellnummer = Artikel-Code + Qualität.
Order No. = Article Code + Quality.

F4003MN – DUO-LOCK® HAIMER MILL Alu Series FASE/CHAMFER

Schnittdaten/Cutting data

HAIMER Werkstoff Gruppen HAIMER Material groups	Beispiel Werkstoffe Example material	Werkstoffnr. Material no.	Werkstoff Information Material information		Schruppen Vc (m/min) Roughing Vc (m/min)	Schlichten Vc (m/min) Finishing Vc (m/min)
			Zugfestigkeit Tensile strength	Inhalt/Härte Content/ Hardness		
N1	Alu-Knetlegierungen Wrought aluminum alloys	AlMg1	3.3315		300 – 400	400 – 500
N2	Alu-Gusslegierungen Aluminum cast alloys	G-Alsi12	3.2581			

Schnittdaten dienen als Richtwerte und müssen dem Bearbeitungsumfeld angepasst werden.
Cutting data are reference values and need to be adjusted according to the application area.

Vorschubtable f_z (mm/Zahn) abhängig von D1 und Schnittbreite a_e / Feed per tooth (mm/tooth) in relation with D1 and cutting width a_e

	ø 10	ø 12	ø 16	ø 20
f _z	0,03 – 0,09	0,03 – 0,10	0,04 – 0,12	0,05 – 0,13

Schnittdaten Basis zylindrische Verlängerung kurz, Schnittdaten bei längeren Auskragungen anpassen.
Cutting data is based on cylindrical extensions short, cutting data for long overhang need to be adjusted.

F4003MN – DUO-LOCK® HAIMER MILL Alu Series FASE/CHAMFER

Technische Daten und Produkteigenschaften/Technical data and Product characteristics



Eigenschaften Characteristics	Anwendung Application	Kühlung Coolant

Feingewuchtet/Fine balanced

Material – Merkmale/Material – characteristics

Haupteinsatz
Main Material



- Beschichtung für abrasive Werkstoffe
- Halsabsatz für längere Eingriffstiefe
- Zentrumschneide
- Polierte Span- und Freiflächen
- Beste Längenwiederholgenauigkeit
- Coating for abrasive materials
- Neck for higher cutting depth
- Center cutting
- Polished flute and relief
- Best length repeatability

Artikel-Code Article-Code	Qualität Quality	Duo-Lock Größe Size	D1 (h9) D1 (h9) [mm]	Schneidecke Cutting edge	Größe Size [mm]	L1 max. L1 max. [mm]	L L [mm]	D2 D2 [mm]	SW AF [mm]	Drehmoment Torque [N/m]
DL10F4003MN1000C..	DC	DL10	10,00	C	0,1	15	20	9,6	SW8	20
DL12F4003MN1200C..	DC	DL12	12,00	C	0,12	18	24	11,5	SW9,5	30
DL16F4003MN1600C..	DC	DL16	16,00	C	0,16	24	32	15,5	SW13	60
DL20F4003MN2000C..	DC	DL20	20,00	C	0,2	30	40	19,3	SW16	80

Bestellnummer = Artikel-Code + Qualität.
Order No. = Article Code + Quality.

H2004UK – DUO-LOCK® HAIMER MILL HF Series

HOCHVORSCHUB KÜHLUNG ZENTRAL/HIGH FEED COOLING CENTRAL

Schnittdaten/Cutting data

HAIMER Werkstoff Gruppen HAIMER Material groups	Beispiel Werkstoffe Example material	Werkstoffnr. Material no.	Werkstoff Information Material information		Schruppen Vc (m/min) Roughing Vc (m/min)	Schlichten Vc (m/min) Finishing Vc (m/min)	
			Zugfestigkeit Tensile strength	Inhalt/Härte Content/ Hardness			
P1	Allg. Bau-, Einsatzstähle General construction steels	S235JR (RST37-2), E295 (St 50-2), C45	1.0038, 1.0050, 1.0503	≤ 800 N/mm ²	bis 25 HRC up to 25 HRC	250 – 320	340 – 420
P2	Werkzeug-/Vergütungsstähle Heat treated steels	X38CrMoV5-3, X153CrMoV12, X100CrMoV5, 42CrMo4	1.2367, 1.2379, 1.2363, 1.7225	> 800 N/mm ²	bis 45 HRC up to 45 HRC	190 – 220	240 – 310
M1	Rostfreie Stähle Stainless steels	X8CrNiS18-9, X5CrNi18-10, X46Cr13	1.4305, 1.4301, 1.4034	≤ 650 N/mm ²		95 – 115	135 – 170
M2	Rostfreie Stähle Stainless steels	X6CrNiMoTi17-12-2, X2CrNiMo17-12-2, X4CrNiMo16-5-1	1.4571, 1.4404, 1.4418	> 650 N/mm ²		75 – 95	105 – 130
K1	Gusseisen Cast iron	EN-GJL200 (GG20), EN-GJLZ (GG40), EN-GJS-400-15 (GGG40)	0.6020, 0.6040, 0.7040	≤ 450 N/mm ²		160 – 180	200 – 230
K2	Gusseisen Cast iron	EN-GJS-600-3 (GGG60), EN-GJS-700-2 (GGG70)	0.7060, 0.7070	> 450 N/mm ²		130 – 150	170 – 200
S1	Titan & Titanlegierungen Titanium & titanium alloys	TiAl6V4	3.7165			50 – 60	80 – 90
S2	Warmfeste Legierungen High Temp alloys	Inconel; NIMONIC		800 – 1700 N/mm ²		30 – 40	30 – 40
N1	Alu-Knetlegierungen Wrought aluminum alloys	AlMg1	3.3315		Si < 9%	500 – 900	500 – 900
N2	Alu-Gusslegierungen Aluminum cast alloys	G-Alsi12	3.2581		Si > 9%	120 – 350	120 – 350
H1	Gehärtete Stähle Hardened steels				45 – 55 HRC	40 – 60	60 – 80

Schnittdaten dienen als Richtwerte und müssen dem Bearbeitungsumfeld angepasst werden.
 Cutting data are reference values and need to be adjusted according to the application area.

Vorschubtable f _z (mm/Zahn) abhängig von D1 und Schnittbreite a _e / Feed per tooth (mm/tooth) in relation with D1 and cutting width a _e				
	∅ 10	∅ 12	∅ 16	∅ 20
f _z	0,1–0,3	0,12–0,36	0,16–0,48	0,2–0,6
a _p HFC	0,75	0,9	1,2	1,5

Schnittdaten Basis zylindrische Verlängerung kurz, Schnittdaten bei längeren Auskragungen anpassen.
 Cutting data is based on cylindrical extensions short, cutting data for long overhang need to be adjusted.

H2004UK – DUO-LOCK® HAIMER MILL HF Series

HOCHVORSCHUB KÜHLUNG ZENTRAL/HIGH FEED COOLING CENTRAL

Technische Daten und Produkteigenschaften/Technical data and Product characteristics



Eigenschaften Characteristics	Anwendung Application	Kühlung Coolant

Material – Merkmale/Material – characteristics

Haupteinsatz
Main Material

auch geeignet für
also suitable for



- Innenkühlung zentral
- Halsabsatz für längere Eingriffstiefe
- Beste Längenwiederholgenauigkeit

- Central inner cooling
- Neck for higher cutting depth
- Best length repeatability

Artikel-Code Article-Code	Qualität Quality	Kühlung Cooling	Duo-Lock Größe Size	D1 (f9) D1 (f9) [mm]	Schneidecke Cutting edge	R1 [mm]	R2 [mm]	Dp [mm]	L1 max. L1 max. [mm]	L [mm]	DKZ [mm]	D2 [mm]	SW AF [mm]	Drehmo. Torque [N/m]
DL10H2004UK1000R..	DA	KZ	DL10	10,00	R	1,5	5	6	7,5	12,5	2	9,6	SW8	20
DL12H2004UK1200R..	DA	KZ	DL12	12,00	R	1,8	6	7,2	9	15	2	11,5	SW9,5	30
DL16H2004UK1600R..	DA	KZ	DL16	16,00	R	2,4	8	9,6	12	20	2	15,5	SW13	60
DL20H2004UK2000R..	DA	KZ	DL20	20,00	R	3	10	12	15	25	3	19,3	SW16	80

Bestellnummer = Artikel-Code + Qualität + Kühlung.
Order No. = Article Code + Quality + Cooling.

H2006UK – DUO-LOCK® HAIMER MILL HF Series

HOCHVORSCHUB KÜHLUNG ZENTRAL/HIGH FEED COOLING CENTRAL

Schnittdaten/Cutting data

HAIMER Werkstoff Gruppen HAIMER Material groups		Beispiel Werkstoffe Example material		Werkstoff Information Material information		Schruppen Vc (m/min) Roughing Vc (m/min)	Schlichten Vc (m/min) Finishing Vc (m/min)
		DIN DIN	Werkstoffnr. Material no.	Zugfestigkeit Tensile strength	Inhalt/Härte Content/ Hardness		
P1	Allg. Bau-, Einsatzstähle General construction steels	S235JR (RST37-2), E295 (St 50-2), C45	1.0038, 1.0050, 1.0503	≤ 800 N/mm ²	bis 25 HRC up to 25 HRC	250 – 320	340 – 420
P2	Werkzeug-/Vergütungsstähle Heat treated steels	X38CrMoV5-3, X153CrMoV12, X100CrMoV5, 42CrMo4	1.2367, 1.2379, 1.2363, 1.7225	> 800 N/mm ²	bis 45 HRC up to 45 HRC	190 – 220	240 – 310
M1	Rostfreie Stähle Stainless steels	X8CrNiS18-9, X5CrNi18-10, X46Cr13	1.4305, 1.4301, 1.4034	≤ 650 N/mm ²		95 – 115	135 – 170
M2	Rostfreie Stähle Stainless steels	X6CrNiMoTi17-12-2, X2CrNiMo17-12-2, X4CrNiMo16-5-1	1.4571, 1.4404, 1.4418	> 650 N/mm ²		75 – 95	105 – 130
K1	Gusseisen Cast iron	EN-GJL200 (GG20), EN-GJLZ (GG40), EN-GJS-400-15 (GGG40)	0.6020, 0.6040, 0.7040	≤ 450 N/mm ²		160 – 180	200 – 230
K2	Gusseisen Cast iron	EN-GJS-600-3 (GGG60), EN-GJS-700-2 (GGG70)	0.7060, 0.7070	> 450 N/mm ²		130 – 150	170 – 200
S1	Titan & Titanlegierungen Titanium & titanium alloys	TiAl6V4	3.7165			50 – 60	80 – 90
S2	Wärmefeste Legierungen High Temp alloys	Inconel; NIMONIC		800 – 1700 N/mm ²		30 – 40	30 – 40
N1	Alu-Knetlegierungen Wrought aluminum alloys	AlMg1	3.3315		Si < 9%	500 – 900	500 – 900
N2	Alu-Gusslegierungen Aluminum cast alloys	G-Alsi12	3.2581		Si > 9%	120 – 350	120 – 350
H1	Gehärtete Stähle Hardened steels				45 – 55 HRC	40 – 60	60 – 80

Schnittdaten dienen als Richtwerte und müssen dem Bearbeitungsumfeld angepasst werden.
 Cutting data are reference values and need to be adjusted according to the application area.

Vorschubtable f _z (mm/Zahn) abhängig von D1 und Schnittbreite a _e / Feed per tooth (mm/tooth) in relation with D1 and cutting width a _e				
	∅ 10	∅ 12	∅ 16	∅ 20
f _z	0,1–0,3	0,12–0,36	0,16–0,48	0,2–0,6
a _p HFC	0,75	0,9	1,2	1,5

Schnittdaten Basis zylindrische Verlängerung kurz, Schnittdaten bei längeren Auskragungen anpassen.
 Cutting data is based on cylindrical extensions short, cutting data for long overhang need to be adjusted.

H2006UK – DUO-LOCK® HAIMER MILL HF Series

HOCHVORSCHUB KÜHLUNG ZENTRAL/HIGH FEED COOLING CENTRAL

Technische Daten und Produkteigenschaften/Technical data and Product characteristics



Eigenschaften Characteristics	Anwendung Application	Kühlung Coolant

Material – Merkmale/Material – characteristics

Haupteinsatz
Main Material



auch geeignet für
also suitable for



- Innenkühlung zentral
- Halsabsatz für längere Eingriffstiefe
- Beste Längenwiederholgenauigkeit

- Inner cooling central
- Neck for higher cutting depth
- Best length repeatability

Artikel-Code Article-Code	Qualität Quality	Kühlung Cooling	Duo-Lock Größe Size	D1 (f9) D1 (f9) [mm]	Schneidecke Cutting edge	R1 [mm]	R2 [mm]	Dp [mm]	L1 max. L1 max. [mm]	L [mm]	DKZ [mm]	D2 [mm]	SW AF [mm]	Drehmo. Torque [N/m]
DL10H2006UK1000R..	DP	KZ	DL10	10,00	R	1,5	5	6	7,5	12,5	2	9,6	SW8	20
DL12H2006UK1200R..	DP	KZ	DL12	12,00	R	1,8	6	7,2	9	15	2	11,5	SW9,5	30
DL16H2006UK1600R..	DP	KZ	DL16	16,00	R	2,4	8	9,6	12	20	2	15,5	SW13	60
DL20H2006UK2000R..	DP	KZ	DL20	20,00	R	3	10	12	15	25	3	19,3	SW16	80

Bestellnummer = Artikel-Code + Qualität + Kühlung.
Order No. = Article Code + Quality + Cooling.

V2002MN – DUO-ΛOCK® HAIMER MILL VOLLRADIUS/BALL NOSE

Schnittdaten/Cutting data

HAIMER Werkstoff Gruppen HAIMER Material groups	Beispiel Werkstoffe Example material	Werkstoffnr. Material no.	Werkstoff Information Material information		Schruppen Vc (m/min) Roughing Vc (m/min)	Schlichten Vc (m/min) Finishing Vc (m/min)	
			Zugfestigkeit Tensile strength	Inhalt/Härte Content/ Hardness			
P1	Allg. Bau-, Einsatzstähle General construction steels	S235JR (RST37-2), E295 (St 50-2), C45	1.0038, 1.0050, 1.0503	≤ 800 N/mm ²	bis 25 HRC up to 25 HRC	160 – 220	220 – 280
P2	Werkzeug-/Vergütungsstähle Heat treated steels	X38CrMoV5-3, X153CrMoV12, X100CrMoV5, 42CrMo4	1.2367, 1.2379, 1.2363, 1.7225	> 800 N/mm ²	bis 45 HRC up to 45 HRC	120 – 160	160 – 200
M1	Rostfreie Stähle Stainless steels	X8CrNiS18-9, X5CrNi18-10, X46Cr13	1.4305, 1.4301, 1.4034	≤ 650 N/mm ²		80 – 120	120 – 160
M2	Rostfreie Stähle Stainless steels	X6CrNiMoTi17-12-2, X2CrNiMo17-12-2, X4CrNiMo16-5-1	1.4571, 1.4404, 1.4418	> 650 N/mm ²		60 – 90	90 – 120
K1	Gusseisen Cast iron	EN-GJL200 (GG20), EN-GJLZ (GG40), EN-GJS-400-15 (GGG40)	0.6020, 0.6040, 0.7040	≤ 450 N/mm ²		120 – 180	180 – 240
K2	Gusseisen Cast iron	EN-GJS-600-3 (GGG60), EN-GJS-700-2 (GGG70)	0.7060, 0.7070	> 450 N/mm ²		80 – 160	160 – 220
S1	Titan & Titanlegierungen Titanium & titanium alloys	TiAl6V4	3.7165			40 – 80	40 – 80
S2	Wärmefeste Legierungen High Temp alloys	Inconel; NIMONIC		800 – 1700 N/mm ²		30 – 40	30 – 40
N1	Alu-Knetlegierungen Wrought aluminum alloys	AlMg1	3.3315		Si < 9%	500 – 900	500 – 900
N2	Alu-Gusslegierungen Aluminum cast alloys	G-Alsi12	3.2581		Si > 9%	120 – 350	120 – 350
H1	Gehärtete Stähle Hardened steels				45 – 55 HRC	40 – 60	60 – 80

Schnittdaten dienen als Richtwerte und müssen dem Bearbeitungsumfeld angepasst werden.
Cutting data are reference values and need to be adjusted according to the application area.

Vorschubtable f _z (mm/Zahn) abhängig von D1 und Schnittbreite ae / Feed per tooth (mm/tooth) in relation with D1 and cutting width ae								
	ø 2	ø 2,5	ø 3	ø 4	ø 5	ø 6	ø 8	ø 10
f _z	0,006 – 0,018	0,008 – 0,023	0,009 – 0,027	0,012 – 0,036	0,015 – 0,045	0,018 – 0,054	0,024 – 0,072	0,03 – 0,09

Schnittdaten Basis zylindrische Verlängerung kurz, Schnittdaten bei längeren Auskragungen anpassen.
Cutting data is based on cylindrical extensions short, cutting data for long overhang need to be adjusted.

V2002MN – DUO-LOCK® HAIMER MILL VOLLRADIUS/BALL NOSE

Technische Daten und Produkteigenschaften/Technical data and Product characteristics



Eigenschaften Characteristics	Anwendung Application	Kühlung Coolant

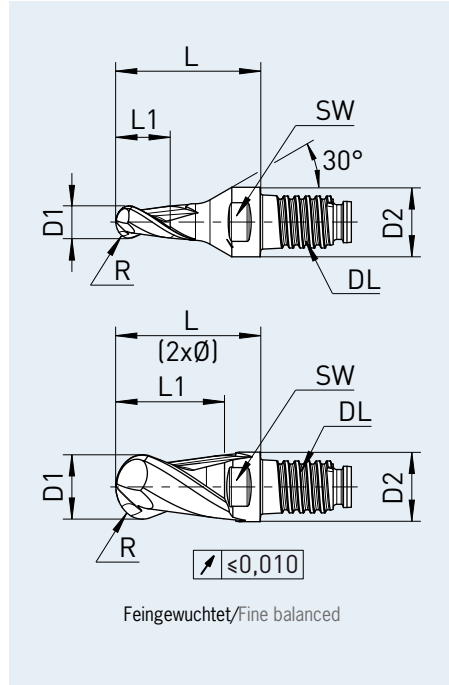

Material – Merkmale/Material – characteristics

Haupteinsatz
Main Material



auch geeignet für
also suitable for



- Halsabsatz für längere Eingriffstiefe
- Vollradius
- Beste Längenwiederholgenauigkeit

- Neck for higher cutting depth
- Ball Nose
- Best length repeatability

Artikel-Code Article-Code	Qualität Quality	Duo-Lock Größe Size	D1 (f9) D1 (f9) [mm]	Schneidecke Cutting edge	Radius Radius [mm]	L1 max. L1 max. [mm]	L L [mm]	D2 D2 [mm]	SW AF [mm]	Drehmoment Torque [N/m]
DL10V2002MN0200R..	DA	DL10	2,00	R	1,00	3,0	20	9,6	SW8	20
DL10V2002MN0250R..	DA	DL10	2,50	R	1,25	3,75	20	9,6	SW8	20
DL10V2002MN0300R..	DA	DL10	3,00	R	1,50	4,5	20	9,6	SW8	20
DL10V2002MN0400R..	DA	DL10	4,00	R	2,00	6,0	20	9,6	SW8	20
DL10V2002MN0500R..	DA	DL10	5,00	R	2,50	7,5	20	9,6	SW8	20
DL10V2002MN0600R..	DA	DL10	6,00	R	3,00	9,0	20	9,6	SW8	20
DL10V2002MN0800R..	DA	DL10	8,00	R	4,00	12	20	9,6	SW8	20
DL10V2002MN1000R..	DA	DL10	10,00	R	5,00	15	20	9,6	SW8	20

Bestellnummer = Artikel-Code + Qualität.
Order No. = Article Code + Quality.

V2002UK – DUO-LOCK® HAIMER MILL VOLLRADIUS/BALL NOSE

Schnittdaten/Cutting data

HAIMER Werkstoff Gruppen HAIMER Material groups	Beispiel Werkstoffe Example material	Werkstoff Information Material information				Schruppen Vc (m/min) Roughing Vc (m/min)	Schlichten Vc (m/min) Finishing Vc (m/min)
		DIN DIN	Werkstoffnr. Material no.	Zugfestigkeit Tensile strength	Inhalt/Härte Content/ Hardness		
P1	Allg. Bau-, Einsatzstähle General construction steels	S235JR (RST37-2), E295 (St 50-2), C45	1.0038, 1.0050, 1.0503	≤ 800 N/mm ²	bis 25 HRC up to 25 HRC	160 – 220	220 – 280
P2	Werkzeug-/Vergütungsstähle Heat treated steels	X38CrMoV5-3, X153CrMoV12, X100CrMoV5, 42CrMo4	1.2367, 1.2379, 1.2363, 1.7225	> 800 N/mm ²	bis 45 HRC up to 45 HRC	120 – 160	160 – 200
M1	Rostfreie Stähle Stainless steels	X8CrNiS18-9, X5CrNi18-10, X46Cr13	1.4305, 1.4301, 1.4034	≤ 650 N/mm ²		80 – 120	120 – 160
M2	Rostfreie Stähle Stainless steels	X6CrNiMoTi17-12-2, X2CrNiMo17-12-2, X4CrNiMo16-5-1	1.4571, 1.4404, 1.4418	> 650 N/mm ²		60 – 90	90 – 120
K1	Gusseisen Cast iron	EN-GJL200 (GG20), EN-GJLZ (GG40), EN-GJS-400-15 (GGG40)	0.6020, 0.6040, 0.7040	≤ 450 N/mm ²		120 – 180	180 – 240
K2	Gusseisen Cast iron	EN-GJS-600-3 (GGG60), EN-GJS-700-2 (GGG70)	0.7060, 0.7070	> 450 N/mm ²		80 – 160	160 – 220
S1	Titan & Titanlegierungen Titanium & titanium alloys	TiAl6V4	3.7165			40 – 80	40 – 80
S2	Wärmefeste Legierungen High Temp alloys	Inconel; NIMONIC		800 – 1700 N/mm ²		30 – 40	30 – 40
N1	Alu-Knetlegierungen Wrought aluminum alloys	AlMg1	3.3315		Si < 9%	500 – 900	500 – 900
N2	Alu-Gusslegierungen Aluminum cast alloys	G-Alsi12	3.2581		Si > 9%	120 – 350	120 – 350
H1	Gehärtete Stähle Hardened steels				45 – 55 HRC	40 – 60	60 – 80

Schnittdaten dienen als Richtwerte und müssen dem Bearbeitungsumfeld angepasst werden.
 Cutting data are reference values and need to be adjusted according to the application area.

Vorschubtable f_z (mm/Zahn) abhängig von D1 und Schnittbreite ae / Feed per tooth (mm/tooth) in relation with D1 and cutting width ae

	∅ 10	∅ 12	∅ 16	∅ 20
f _z	0,03 – 0,09	0,03 – 0,10	0,04 – 0,12	0,05 – 0,13

Schnittdaten Basis zylindrische Verlängerung kurz, Schnittdaten bei längeren Auskrägungen anpassen.
 Cutting data is based on cylindrical extensions short, cutting data for long overhang need to be adjusted.

V2002UK – DUO-LOCK® HAIMER MILL VOLLRADIUS/BALL NOSE

Technische Daten und Produkteigenschaften/Technical data and Product characteristics



Eigenschaften Characteristics	Anwendung Application	Kühlung Coolant

Feingewuchtet/Fine balanced

Material – Merkmale/Material – characteristics

Haupteinsatz
Main Material



auch geeignet für
also suitable for



- Halsabsatz für längere Eingriffstiefe
- Vollradius
- Beste Längenwiederholgenauigkeit

- Neck for higher cutting depth
- Ball Nose
- Best length repeatability

Artikel-Code Article-Code	Qualität Quality	Duo-Lock Größe Size	D1 (f9) D1 (f9) [mm]	Schneidecke Cutting edge	Radius Radius [mm]	L1 max. L1 max. [mm]	L L [mm]	D2 D2 [mm]	SW AF [mm]	Drehmoment Torque [N/m]
DL10V2002UK1000R..	DA	DL10	10,00	R	5,00	7,5	12,5	9,6	SW8	20
DL12V2002UK1200R..	DA	DL12	12,00	R	6,00	9	15	11,5	SW9,5	30
DL16V2002UK1600R..	DA	DL16	16,00	R	8,00	12	20	15,5	SW13	60
DL20V2002UK2000R..	DA	DL20	20,00	R	10,00	15	25	19,3	SW16	80

Bestellnummer = Artikel-Code + Qualität.
Order No. = Article Code + Quality.

V2002UK – DUO-LOCK® HAIMER MILL

VOLLRADIUS KÜHLUNG RADIAL/BALL NOSE COOLING RADIAL

Schnittdaten/Cutting data

HAIMER Werkstoff Gruppen HAIMER Material groups	Beispiel Werkstoffe Example material	Werkstoff Information Material information				Schruppen Vc (m/min) Roughing Vc (m/min)	Schlichten Vc (m/min) Finishing Vc (m/min)
		DIN DIN	Werkstoffnr. Material no.	Zugfestigkeit Tensile strength	Inhalt/Härte Content/ Hardness		
P1	Allg. Bau-, Einsatzstähle General construction steels	S235JR (RST37-2), E295 (St 50-2), C45	1.0038, 1.0050, 1.0503	≤ 800 N/mm ²	bis 25 HRC up to 25 HRC	160 – 220	220 – 280
P2	Werkzeug-/ Vergütungsstähle Heat treated steels	X38CrMoV5-3, X153CrMoV12, X100CrMoV5, 42CrMo4	1.2367, 1.2379, 1.2363, 1.7225	> 800 N/mm ²	bis 45 HRC up to 45 HRC	120 – 160	160 – 200
M1	Rostfreie Stähle Stainless steels	X8CrNiS18-9, X5CrNi18-10, X46Cr13	1.4305, 1.4301, 1.4034	≤ 650 N/mm ²		80 – 120	120 – 160
M2	Rostfreie Stähle Stainless steels	X6CrNiMoTi17-12-2, X2CrNiMo17-12-2, X4CrNiMo16-5-1	1.4571, 1.4404, 1.4418	> 650 N/mm ²		60 – 90	90 – 120
K1	Gusseisen Cast iron	EN-GJL200 (GG20), EN- GJLZ (GG40), EN- GJS-400-15 (GGG40)	0.6020, 0.6040, 0.7040	≤ 450 N/mm ²		120 – 180	180 – 240
K2	Gusseisen Cast iron	EN-GJS-600-3 (GGG60), EN-GJS-700-2 (GGG70)	0.7060, 0.7070	> 450 N/mm ²		80 – 160	160 – 220
S1	Titan & Titanlegierungen Titanium & titanium alloys	TiAl6V4	3.7165			40 – 80	40 – 80
S2	Warmfeste Legierungen High Temp alloys	Inconel; NIMONIC		800 – 1700 N/mm ²		30 – 40	30 – 40
N1	Alu-Knetlegierungen Wrought aluminum alloys	AlMg1	3.3315		Si < 9%	500 – 900	500 – 900
N2	Alu-Gusslegierungen Aluminum cast alloys	G-Alsi12	3.2581		Si > 9%	120 – 350	120 – 350
H1	Gehärtete Stähle Hardened steels				45 – 55 HRC	40 – 60	60 – 80

Schnittdaten dienen als Richtwerte und müssen dem Bearbeitungsumfeld angepasst werden.
 Cutting data are reference values and need to be adjusted according to the application area.

Vorschubtable f_z (mm/Zahn) abhängig von D1 und Schnittbreite ae / Feed per tooth (mm/tooth) in relation with D1 and cutting width ae

	ø 10	ø 12	ø 16	ø 20
f _z	0,03 – 0,09	0,03 – 0,10	0,04 – 0,12	0,05 – 0,13

Schnittdaten Basis zylindrische Verlängerung kurz, Schnittdaten bei längeren Auskragungen anpassen.
 Cutting data is based on cylindrical extensions short, cutting data for long overhang need to be adjusted.

V2002UK – DUO-LOCK® HAIMER MILL VOLLRADIUS KÜHLUNG RADIAL/BALL NOSE COOLING RADIAL

Technische Daten und Produkteigenschaften/Technical data and Product characteristics



Eigenschaften Characteristics	Anwendung Application	Kühlung Coolant

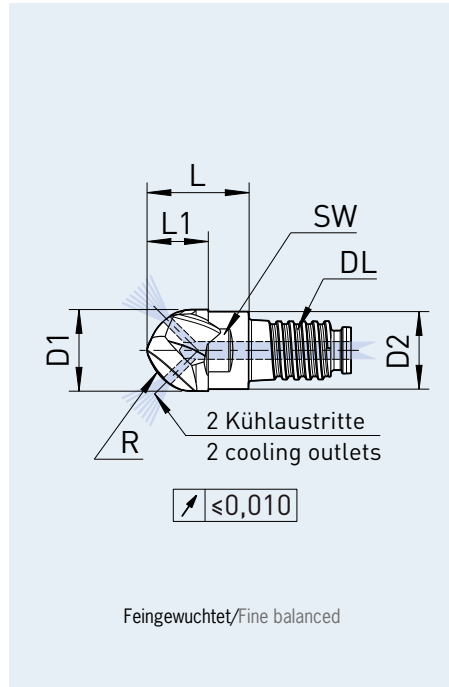

Material – Merkmale/Material – characteristics

Haupteinsatz
Main Material



auch geeignet für
also suitable for



- Innenkühlung radial
- Halsabsatz für längere Eingriffstiefe
- Vollradius
- Beste Längenwiederholgenauigkeit

- Inner cooling radial
- Neck for higher cutting depth
- Ball Nose
- Best length repeatability

Artikel-Code Article-Code	Qualität Quality	Kühlung Cooling	Duo-Lock Größe Size	D1 (f9) D1 (f9) [mm]	Schneidecke Cutting edge	Radius Radius [mm]	L1 max. L1 max. [mm]	L L [mm]	D2 D2 [mm]	SW AF [mm]	Drehmoment Torque [N/m]
DL10V2002UK1000R..	DA	KR	DL10	10,00	R	5,00	7,5	12,5	9,6	SW8	20
DL12V2002UK1200R..	DA	KR	DL12	12,00	R	6,00	9	15	11,5	SW9,5	30
DL16V2002UK1600R..	DA	KR	DL16	16,00	R	8,00	12	20	15,5	SW13	60
DL20V2002UK2000R..	DA	KR	DL20	20,00	R	10,00	15	25	19,3	SW16	80

Bestellnummer = Artikel-Code + Qualität + Kühlung.
Order No. = Article Code + Quality + Cooling.

V2004MN – DUO-LOCK® HAIMER MILL VOLLRADIUS/BALL NOSE

Schnittdaten/Cutting data

HAIMER Werkstoff Gruppen HAIMER Material groups	Beispiel Werkstoffe Example material	Werkstoff Information Material information				Schruppen Vc (m/min) Roughing Vc (m/min)	Schlichten Vc (m/min) Finishing Vc (m/min)
		DIN DIN	Werkstoffnr. Material no.	Zugfestigkeit Tensile strength	Inhalt/Härte Content/ Hardness		
P1	Allg. Bau-, Einsatzstähle General construction steels	S235JR (RST37-2), E295 (St 50-2), C45	1.0038, 1.0050, 1.0503	≤ 800 N/mm ²	bis 25 HRC up to 25 HRC	160 – 220	220 – 280
P2	Werkzeug/ Vergütungsstähle Heat treated steels	X38CrMoV5-3, X153CrMoV12, X100CrMoV5, 42CrMo4	1.2367, 1.2379, 1.2363, 1.7225	> 800 N/mm ²	bis 45 HRC up to 45 HRC	120 – 160	160 – 200
M1	Rostfreie Stähle Stainless steels	X8CrNiS18-9, X5CrNi18-10, X46Cr13	1.4305, 1.4301, 1.4034	≤ 650 N/mm ²		80 – 120	120 – 160
M2	Rostfreie Stähle Stainless steels	X6CrNiMoTi17-12-2, X2CrNiMo17-12-2, X4CrNiMo16-5-1	1.4571, 1.4404, 1.4418	> 650 N/mm ²		60 – 90	90 – 120
K1	Gusseisen Cast iron	EN-GJL200 (GG20), EN- GJLZ (GG40), EN- GJS-400-15 (GGG40)	0.6020, 0.6040, 0.7040	≤ 450 N/mm ²		120 – 180	180 – 240
K2	Gusseisen Cast iron	EN-GJS-600-3 (GGG60), EN-GJS-700-2 (GGG70)	0.7060, 0.7070	> 450 N/mm ²		80 – 160	160 – 220
S1	Titan & Titanlegierungen Titanium & titanium alloys	TiAl6V4	3.7165			40 – 80	40 – 80
S2	Wärmefeste Legierungen High Temp alloys	Inconel; NIMONIC		800 – 1700 N/mm ²		30 – 40	30 – 40
N1	Alu-Knetlegierungen Wrought aluminum alloys	AlMg1	3.3315		Si < 9%	500 – 900	500 – 900
N2	Alu-Gusslegierungen Aluminum cast alloys	G-Alsi12	3.2581		Si > 9%	120 – 350	120 – 350
H1	Gehärtete Stähle Hardened steels				45 – 55 HRC	40 – 60	60 – 80

Schnittdaten dienen als Richtwerte und müssen dem Bearbeitungsumfeld angepasst werden.
 Cutting data are reference values and need to be adjusted according to the application area.

Vorschubtable f_z (mm/Zahn) abhängig von D1 und Schnittbreite ae / Feed per tooth (mm/tooth) in relation with D1 and cutting width ae

	ø 2	ø 2,5	ø 3	ø 4	ø 5	ø 6	ø 8	ø 10
f _z	0,006 – 0,018	0,008 – 0,023	0,009 – 0,027	0,012 – 0,036	0,015 – 0,045	0,018 – 0,054	0,024 – 0,072	0,03 – 0,09

Schnittdaten Basis zylindrische Verlängerung kurz, Schnittdaten bei längeren Auskragungen anpassen.
 Cutting data is based on cylindrical extensions short, cutting data for long overhang need to be adjusted.

V2004MN – DUO-LOCK® HAIMER MILL VOLLRADIUS/BALL NOSE

Technische Daten und Produkteigenschaften/Technical data and Product characteristics



Eigenschaften Characteristics	Anwendung Application	Kühlung Coolant

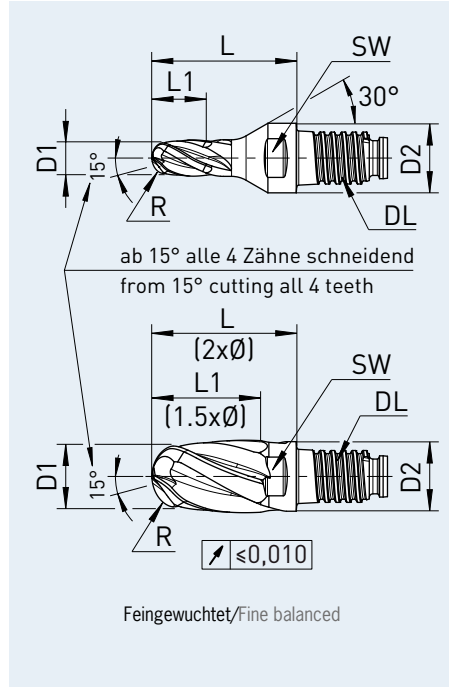

Material – Merkmale/Material – characteristics

Haupteinsatz
Main Material



auch geeignet für
also suitable for



- Halsabsatz für längere Eingriffstiefe
- Vollradius
- Beste Längenwiederholgenauigkeit

- Neck for higher cutting depth
- Ball Nose
- Best length repeatability

Artikel-Code Article-Code	Qualität Quality	Duo-Lock Größe Size	D1 (f9) D1 (f9) [mm]	Schneidecke Cutting edge	Radius Radius [mm]	L1 max. L1 max. [mm]	L L [mm]	D2 D2 [mm]	SW AF [mm]	Drehmoment Torque [N/m]
DL10V2004MN0200R..	DA	DL10	2,00	R	1,00	3,0	20	9,6	SW8	20
DL10V2004MN0250R..	DA	DL10	2,50	R	1,25	3,75	20	9,6	SW8	20
DL10V2004MN0300R..	DA	DL10	3,00	R	1,50	4,5	20	9,6	SW8	20
DL10V2004MN0400R..	DA	DL10	4,00	R	2,00	6,0	20	9,6	SW8	20
DL10V2004MN0500R..	DA	DL10	5,00	R	2,50	7,5	20	9,6	SW8	20
DL10V2004MN0600R..	DA	DL10	6,00	R	3,00	9,0	20	9,6	SW8	20
DL10V2004MN0800R..	DA	DL10	8,00	R	4,00	12	20	9,6	SW8	20
DL10V2004MN1000R..	DA	DL10	10,00	R	5,00	15	20	9,6	SW8	20

Bestellnummer = Artikel-Code + Qualität.
Order No. = Article Code + Quality.

V2004UK – DUO-LOCK® HAIMER MILL VOLLRADIUS/BALL NOSE

Schnittdaten/Cutting data

HAIMER Werkstoff Gruppen HAIMER Material groups	Beispiel Werkstoffe Example material	Werkstoff Information Material information				Schruppen Vc (m/min) Roughing Vc (m/min)	Schlichten Vc (m/min) Finishing Vc (m/min)
		DIN DIN	Werkstoffnr. Material no.	Zugfestigkeit Tensile strength	Inhalt/Härte Content/ Hardness		
P1	Allg. Bau-, Einsatzstähle General construction steels	S235JR (RST37-2), E295 (St 50-2), C45	1.0038, 1.0050, 1.0503	≤ 800 N/mm ²	bis 25 HRC up to 25 HRC	160 – 220	220 – 280
P2	Werkzeug-/Vergütungsstähle Heat treated steels	X38CrMoV5-3, X153CrMoV12, X100CrMoV5, 42CrMo4	1.2367, 1.2379, 1.2363, 1.7225	> 800 N/mm ²	bis 45 HRC up to 45 HRC	120 – 160	160 – 200
M1	Rostfreie Stähle Stainless steels	X8CrNiS18-9, X5CrNi18-10, X46Cr13	1.4305, 1.4301, 1.4034	≤ 650 N/mm ²		80 – 120	120 – 160
M2	Rostfreie Stähle Stainless steels	X6CrNiMoTi17-12-2, X2CrNiMo17-12-2, X4CrNiMo16-5-1	1.4571, 1.4404, 1.4418	> 650 N/mm ²		60 – 90	90 – 120
K1	Gusseisen Cast iron	EN-GJL200 (GG20), EN-GJLZ (GG40), EN-GJS-400-15 (GGG40)	0.6020, 0.6040, 0.7040	≤ 450 N/mm ²		120 – 180	180 – 240
K2	Gusseisen Cast iron	EN-GJS-600-3 (GGG60), EN-GJS-700-2 (GGG70)	0.7060, 0.7070	> 450 N/mm ²		80 – 160	160 – 220
S1	Titan & Titanlegierungen Titanium & titanium alloys	TiAl6V4	3.7165			40 – 80	40 – 80
S2	Wärmefeste Legierungen High Temp alloys	Inconel; NIMONIC		800 – 1700 N/mm ²		30 – 40	30 – 40
N1	Alu-Knetlegierungen Wrought aluminum alloys	AlMg1	3.3315		Si < 9%	500 – 900	500 – 900
N2	Alu-Gusslegierungen Aluminum cast alloys	G-Alsi12	3.2581		Si > 9%	120 – 350	120 – 350
H1	Gehärtete Stähle Hardened steels				45 – 55 HRC	40 – 60	60 – 80

Schnittdaten dienen als Richtwerte und müssen dem Bearbeitungsumfeld angepasst werden.
Cutting data are reference values and need to be adjusted according to the application area.

Vorschubtable f_z (mm/Zahn) abhängig von D1 und Schnittbreite ae / Feed per tooth (mm/tooth) in relation with D1 and cutting width ae

	∅ 10	∅ 12	∅ 16	∅ 20
f _z	0,03 – 0,09	0,03 – 0,10	0,04 – 0,12	0,05 – 0,13

Schnittdaten Basis zylindrische Verlängerung kurz, Schnittdaten bei längeren Auskragungen anpassen.
Cutting data is based on cylindrical extensions short, cutting data for long overhang need to be adjusted.

V2004UK – DUO-LOCK® HAIMER MILL VOLLRADIUS/BALL NOSE

Technische Daten und Produkteigenschaften/Technical data and Product characteristics



Eigenschaften Characteristics	Anwendung Application	Kühlung Coolant

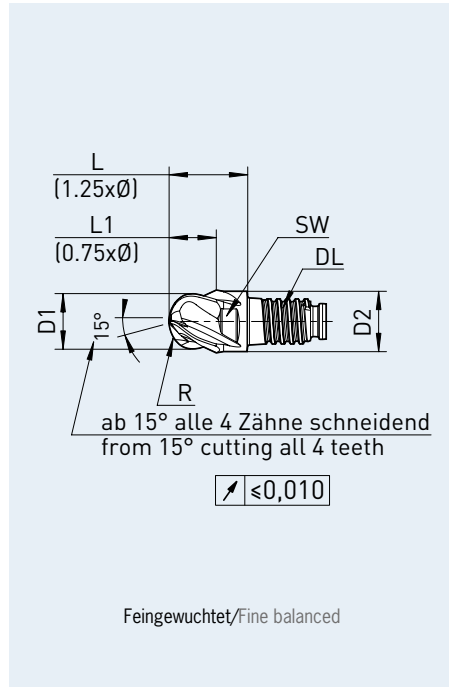

Material – Merkmale/Material – characteristics

Hauptmaterial
Main Material

auch geeignet für
also suitable for



- Halsabsatz für längere Eingriffstiefe
- Vollradius
- Beste Längenwiederholgenauigkeit

- Neck for higher cutting depth
- Ball Nose
- Best length repeatability

Artikel-Code Article-Code	Qualität Quality	Duo-Lock Größe Size	D1 (f9) D1 (f9) [mm]	Schneidecke Cutting edge	Radius Radius [mm]	L1 max. L1 max. [mm]	L L [mm]	D2 D2 [mm]	SW AF [mm]	Drehmoment Torque [N/m]
DL10V2004UK1000R..	DA	DL10	10,00	R	5,00	7,5	12,5	9,6	SW8	20
DL12V2004UK1200R..	DA	DL12	12,00	R	6,00	9	15	11,5	SW9,5	30
DL16V2004UK1600R..	DA	DL16	16,00	R	8,00	12	20	15,5	SW13	60
DL20V2004UK2000R..	DA	DL20	20,00	R	10,00	15	25	19,3	SW16	80

Bestellnummer = Artikel-Code + Qualität.
Order No. = Article Code + Quality.

V2004UK – DUO-LOCK® HAIMER MILL

VOLLRADIUS KÜHLUNG RADIAL/BALL NOSE COOLING RADIAL

Schnittdaten/Cutting data

HAIMER Werkstoff Gruppen HAIMER Material groups	Beispiel Werkstoffe Example material	Werkstoffnr. Material no.	Werkstoff Information Material information		Schruppen Vc (m/min) Roughing Vc (m/min)	Schlichten Vc (m/min) Finishing Vc (m/min)	
			Zugfestigkeit Tensile strength	Inhalt/Härte Content/ Hardness			
P1	Allg. Bau-, Einsatzstähle General construction steels	S235JR (RST37-2), E295 (St 50-2), C45	1.0038, 1.0050, 1.0503	≤ 800 N/mm ²	bis 25 HRC up to 25 HRC	160 – 220	220 – 280
P2	Werkzeug-/Vergütungsstähle Heat treated steels	X38CrMoV5-3, X153CrMoV12, X100CrMoV5, 42CrMo4	1.2367, 1.2379, 1.2363, 1.7225	> 800 N/mm ²	bis 45 HRC up to 45 HRC	120 – 160	160 – 200
M1	Rostfreie Stähle Stainless steels	X8CrNiS18-9, X5CrNi18-10, X46Cr13	1.4305, 1.4301, 1.4034	≤ 650 N/mm ²		80 – 120	120 – 160
M2	Rostfreie Stähle Stainless steels	X6CrNiMoTi17-12-2, X2CrNiMo17-12-2, X4CrNiMo16-5-1	1.4571, 1.4404, 1.4418	> 650 N/mm ²		60 – 90	90 – 120
K1	Gusseisen Cast iron	EN-GJL200 (GG20), EN-GJLZ (GG40), EN-GJS-400-15 (GGG40)	0.6020, 0.6040, 0.7040	≤ 450 N/mm ²		120 – 180	180 – 240
K2	Gusseisen Cast iron	EN-GJS-600-3 (GGG60), EN-GJS-700-2 (GGG70)	0.7060, 0.7070	> 450 N/mm ²		80 – 160	160 – 220
S1	Titan & Titanlegierungen Titanium & titanium alloys	TiAl6V4	3.7165			40 – 80	40 – 80
S2	Wärmefeste Legierungen High Temp alloys	Inconel; NIMONIC		800 – 1700 N/mm ²		30 – 40	30 – 40
N1	Alu-Knetlegierungen Wrought aluminum alloys	AlMg1	3.3315		Si < 9%	500 – 900	500 – 900
N2	Alu-Gusslegierungen Aluminum cast alloys	G-Alsi12	3.2581		Si > 9%	120 – 350	120 – 350
H1	Gehärtete Stähle Hardened steels				45 – 55 HRC	40 – 60	60 – 80

Schnittdaten dienen als Richtwerte und müssen dem Bearbeitungsumfeld angepasst werden.
 Cutting data are reference values and need to be adjusted according to the application area.

Vorschubtable f_z (mm/Zahn) abhängig von D1 und Schnittbreite ae / Feed per tooth (mm/tooth) in relation with D1 and cutting width ae

	ø 10	ø 12	ø 16	ø 20
f _z	0,03 – 0,09	0,03 – 0,10	0,04 – 0,12	0,05 – 0,13

Schnittdaten Basis zylindrische Verlängerung kurz, Schnittdaten bei längeren Auskragungen anpassen.
 Cutting data is based on cylindrical extensions short, cutting data for long overhang need to be adjusted.

V2004UK – DUO-LOCK® HAIMER MILL VOLLRADIUS KÜHLUNG RADIAL/BALL NOSE COOLING RADIAL

Technische Daten und Produkteigenschaften/Technical data and Product characteristics



Eigenschaften Characteristics	Anwendung Application	Kühlung Coolant

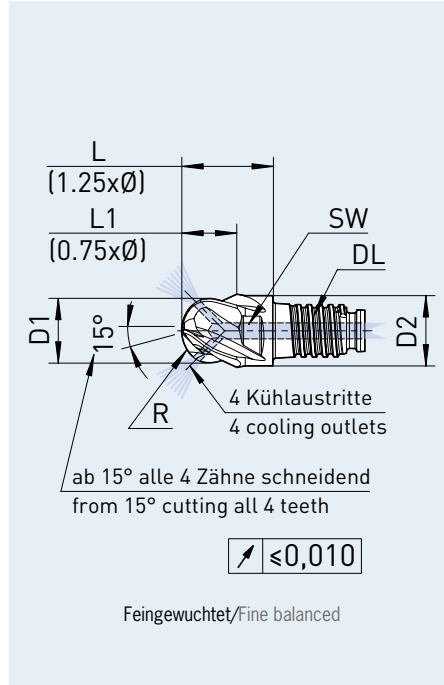

Material – Merkmale/Material – characteristics

Hauptmaterial
Main Material



auch geeignet für
also suitable for



- Innenkühlung radial
- Halsabsatz für längere Eingriffstiefe
- Vollradius
- Beste Längenwiederholgenauigkeit

- Inner cooling radial
- Neck for higher cutting depth
- Ball Nose
- Best length repeatability

Artikel-Code Article-Code	Qualität Quality	Kühlung Cooling	Duo-Lock Größe Size	D1 (f9) D1 (f9) [mm]	Schneidecke Cutting edge	Radius Radius [mm]	L1 max. L1 max. [mm]	L L [mm]	D2 D2 [mm]	SW AF [mm]	Drehmoment Torque [N/m]
DL10V2004UK1000R..	DA	KR	DL10	10,00	R	5,00	7,5	12,5	9,6	SW8	20
DL12V2004UK1200R..	DA	KR	DL12	12,00	R	6,00	9	15	11,5	SW9,5	30
DL16V2004UK1600R..	DA	KR	DL16	16,00	R	8,00	12	20	15,5	SW13	60
DL20V2004UK2000R..	DA	KR	DL20	20,00	R	10,00	15	25	19,3	SW16	80

Bestellnummer = Artikel-Code + Qualität + Kühlung.
Order No. = Article Code + Quality + Cooling.

V4002UK – DUO-LOCK® HAIMER MILL Alu Series VOLLRADIUS/BALL NOSE

Schnittdaten/Cutting data

HAIMER Werkstoff Gruppen HAIMER Material groups	Beispiel Werkstoffe Example material	Werkstoffnr. Material no.	Werkstoff Information Material information		Schruppen Vc (m/min) Roughing Vc (m/min)	Schlichten Vc (m/min) Finishing Vc (m/min)
			Zugfestigkeit Tensile strength	Inhalt/Härte Content/ Hardness		
N1	Alu-Knetlegierungen Wrought aluminum alloys	AlMg1	3.3315		300 – 400	400 – 500
N2	Alu-Gusslegierungen Aluminum cast alloys	G-Alsi12	3.2581			

Schnittdaten dienen als Richtwerte und müssen dem Bearbeitungsumfeld angepasst werden.
Cutting data are reference values and need to be adjusted according to the application area.

Vorschubtable f_z (mm/Zahn) abhängig von D1 und Schnittbreite a_e / Feed per tooth (mm/tooth) in relation with D1 and cutting width a_e

	ø 10	ø 12	ø 16	ø 20
f _z	0,03 – 0,09	0,03 – 0,10	0,04 – 0,12	0,05 – 0,13

Schnittdaten Basis zylindrische Verlängerung kurz, Schnittdaten bei längeren Auskragungen anpassen.
Cutting data is based on cylindrical extensions short, cutting data for long overhang need to be adjusted.

V4002UK – DUO-LOCK® HAIMER MILL Alu Series VOLLRADIUS/BALL NOSE

Technische Daten und Produkteigenschaften/Technical data and Product characteristics



Eigenschaften Characteristics	Anwendung Application	Kühlung Coolant
0.75 × Ø		
VR	45°	Air
Z=2		
10°		

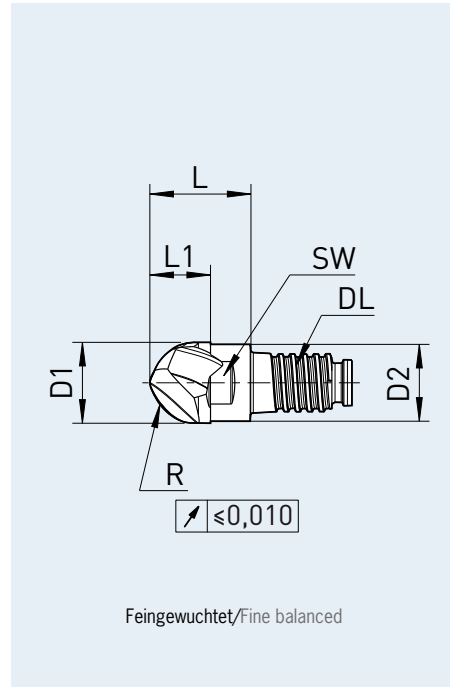

Material – Merkmale/Material – characteristics

Haupteinsatz
Main Material



- Halsabsatz für längere Eingriffstiefe
- Zentrumschneide
- Polierte Span- und Freiflächen
- Beste Längenwiederholgenauigkeit
- Neck for higher cutting depth
- Center cutting
- Polished flute and relief
- Best length repeatability

Artikel-Code Article-Code	Qualität Quality	Duo-Lock Größe Size	D1 (h9) D1 (h9) [mm]	Schneidecke Cutting edge	Größe Size [mm]	L1 max. L1 max. [mm]	L L [mm]	D2 D2 [mm]	SW AF [mm]	Drehmoment Torque [N/m]
DL10V4002UK1000R..	D-	DL10	10,00	R	5,00	7,5	12,5	9,6	SW8	20
DL12V4002UK1200R..	D-	DL12	12,00	R	6,00	9	15	11,5	SW9,5	30
DL16V4002UK1600R..	D-	DL16	16,00	R	8,00	12	20	15,5	SW13	60
DL20V4002UK2000R..	D-	DL20	20,00	R	10,00	15	25	19,3	SW16	80

Bestellnummer = Artikel-Code + Qualität.
Order No. = Article Code + Quality.

V4002UK – DUO-LOCK® HAIMER MILL Alu Series VOLLRADIUS/BALL NOSE

Schnittdaten/Cutting data

HAIMER Werkstoff Gruppen HAIMER Material groups	Beispiel Werkstoffe Example material	Werkstoffnr. Material no.	Werkstoff Information Material information		Schruppen Vc (m/min) Roughing Vc (m/min)	Schlichten Vc (m/min) Finishing Vc (m/min)
			Zugfestigkeit Tensile strength	Inhalt/Härte Content/ Hardness		
N1	Alu-Knetlegierungen Wrought aluminum alloys	AlMg1	3.3315		300 – 400	400 – 500
N2	Alu-Gusslegierungen Aluminum cast alloys	G-Alsi12	3.2581			

Schnittdaten dienen als Richtwerte und müssen dem Bearbeitungsumfeld angepasst werden.
Cutting data are reference values and need to be adjusted according to the application area.

Vorschubtable f_z (mm/Zahn) abhängig von D1 und Schnittbreite a_e / Feed per tooth (mm/tooth) in relation with D1 and cutting width a_e

	ø 10	ø 12	ø 16	ø 20
f _z	0,03 – 0,09	0,03 – 0,10	0,04 – 0,12	0,05 – 0,13

Schnittdaten Basis zylindrische Verlängerung kurz, Schnittdaten bei längeren Auskragungen anpassen.
Cutting data is based on cylindrical extensions short, cutting data for long overhang need to be adjusted.

V4002UK – DUO-LOCK® HAIMER MILL Alu Series VOLLRADIUS/BALL NOSE

Technische Daten und Produkteigenschaften/Technical data and Product characteristics



Eigenschaften Characteristics	Anwendung Application	Kühlung Coolant

Feingewuchtet/Fine balanced

Material – Merkmale/Material – characteristics

Haupteinsatz
Main Material



- Beschichtung für abrasive Werkstoffe
- Halsabsatz für längere Eingriffstiefe
- Zentrumsschneide
- Polierte Span- und Freiflächen
- Beste Längenwiederholgenauigkeit
- Coating for abrasive materials
- Neck for higher cutting depth
- Center cutting
- Polished flute and relief
- Best length repeatability

Artikel-Code Article-Code	Qualität Quality	Duo-Lock Größe Size	D1 (h9) D1 (h9) [mm]	Schneidecke Cutting edge	Größe Size [mm]	L1 max. L1 max. [mm]	L L [mm]	D2 D2 [mm]	SW AF [mm]	Drehmoment Torque [N/m]
DL10V4002UK1000R..	DC	DL10	10,00	R	5,00	7,5	12,5	9,6	SW8	20
DL12V4002UK1200R..	DC	DL12	12,00	R	6,00	9	15	11,5	SW9,5	30
DL16V4002UK1600R..	DC	DL16	16,00	R	8,00	12	20	15,5	SW13	60
DL20V4002UK2000R..	DC	DL20	20,00	R	10,00	15	25	19,3	SW16	80

Bestellnummer = Artikel-Code + Qualität.
Order No. = Article Code + Quality.

DUO-LOCK® ROHLING – OHNE SCHLÜSSELWEITE DUO-LOCK® BLANK – WITHOUT ACROSS FLATS

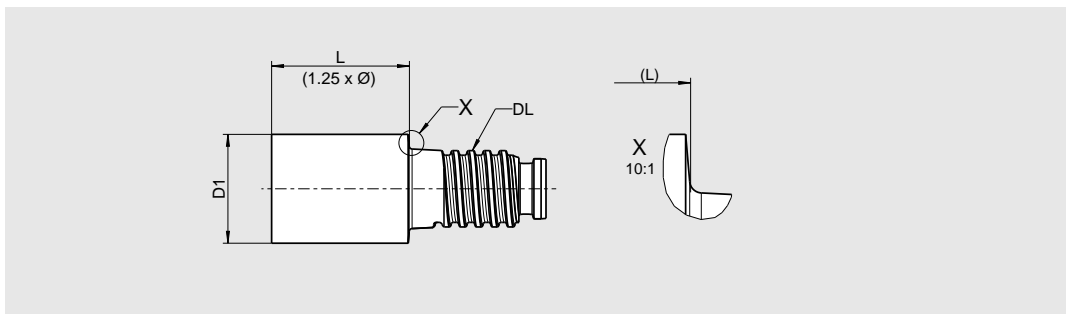

Ausführung: kurz, ohne Schlüsselweite

- Beste Längenwiederholgenauigkeit
- HF10: Feinstkorn-Hartmetall, 10% Kobalt

Version: short, without across flats

- Best length repeatability
- HF10: Fine grain carbide, 10% cobalt

Artikel-Code Article-Code	D1 (h6) D1 (h6) [mm]	L (+ 1) L (+ 1) [mm]	Schnittstelle Interface	Anzugsdrehmoment Tightening torque [Nm]	SW AF [mm]	Material Material
RODL10-D10HA0125-0001	10	12,5	DL10	20	8	HF10
RODL12-D12HA0150-0001	12	15	DL12	30	9,5	HF10
RODL16-D16HA0200-0001	16	20	DL16	60	13	HF10
RODL20-D20HA0250-0001	20	25	DL20	80	16	HF10
RODL25-D25HA0313-0001	25	31,25	DL25	100	21	HF10
RODL32-D32HA0400-0001	32	40	DL32	130	28	HF10

Weitere Längen und Längenmessvorrichtungen auf Anfrage/Further lengths and measuring devices available on request

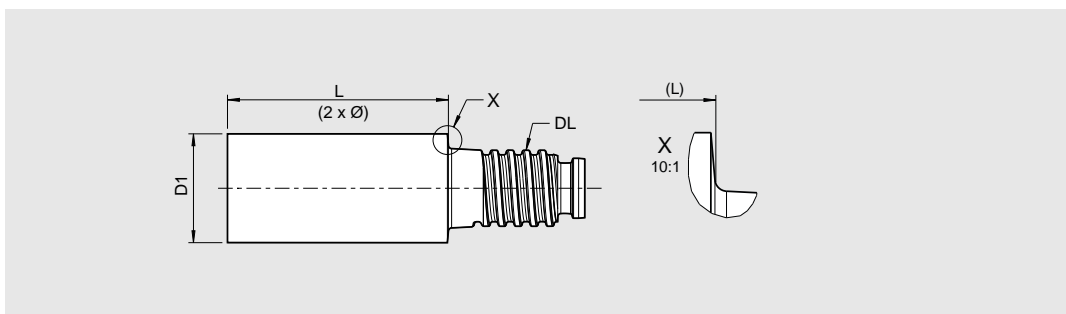

Ausführung: normal, ohne Schlüsselweite

- Beste Längenwiederholgenauigkeit
- HF10: Feinstkorn-Hartmetall, 10% Kobalt

Version: normal, without across flats

- Best length repeatability
- HF10: Fine grain carbide, 10% cobalt

Artikel-Code Article-Code	D1 (h6) D1 (h6) [mm]	L (+ 1) L (+ 1) [mm]	Schnittstelle Interface	Anzugsdrehmoment Tightening torque [Nm]	SW AF [mm]	Material Material
RODL10-D10HA0200-0001	10	20	DL10	20	8	HF10
RODL12-D12HA0240-0001	12	24	DL12	30	9,5	HF10
RODL16-D16HA0320-0001	16	32	DL16	60	13	HF10
RODL20-D20HA0400-0001	20	40	DL20	80	16	HF10
RODL25-D25HA0500-0001	25	50	DL25	100	21	HF10
RODL32-D32HA0640-0001	32	64	DL32	130	28	HF10

Weitere Längen und Längenmessvorrichtungen auf Anfrage/Further lengths and measuring devices available on request

Schlüsselweitenübersicht beachten. Nur mit Duo-Lock Torque Master verwenden. Mindestabstand zur Planfläche einhalten (Siehe Seite 189)
Pay attention to across flats overview. Use only with Duo-Lock Torque Master. Keep minimum length to plain surface (See page 189)

DUO-LOCK® ROHLING KÜHLBOHRUNG ZENTRAL – OHNE SCHLÜSSELWEITE

DUO-LOCK® BLANK COOLING BORE CENTRAL – WITHOUT ACROSS FLATS

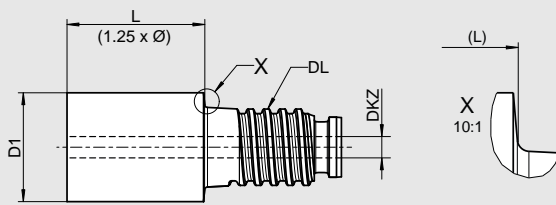

Ausführung: kurz, ohne Schlüsselweite

- Beste Längenwiederholgenauigkeit
- HF10: Feinstkorn-Hartmetall, 10% Kobalt
- Zentrale Kühlung

Version: short, without across flats

- Best length repeatability
- HF10: Fine grain carbide, 10% cobalt
- Central cooling

Artikel-Code Article-Code	D1 (h6) D1 (h6) [mm]	L (+ 1) L (+ 1) [mm]	Schnittstelle Interface	DKZ DKZ [mm]	Anzugsdrehmoment Tightening torque [Nm]	SW AF [mm]	Material Material
RODL10-D10HA0125-0001KZ	10	12,5	DL10	2	20	8	HF10
RODL12-D12HA0150-0001KZ	12	15	DL12	2	30	9,5	HF10
RODL16-D16HA0200-0001KZ	16	20	DL16	2	60	13	HF10
RODL20-D20HA0250-0001KZ	20	25	DL20	3	80	16	HF10
RODL25-D25HA0313-0001KZ	25	31,25	DL25	4	100	21	HF10
RODL32-D32HA0400-0001KZ	32	40	DL32	5	130	28	HF10

Weitere Längen und Längenmessvorrichtungen auf Anfrage/Further lengths and measuring devices available on request

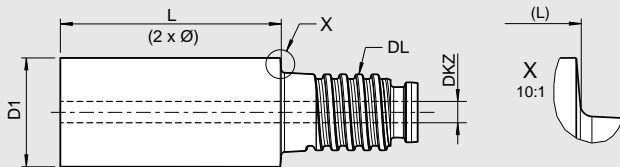

Ausführung: normal, ohne Schlüsselweite

- Beste Längenwiederholgenauigkeit
- HF10: Feinstkorn-Hartmetall, 10% Kobalt
- Zentrale Kühlung

Version: normal, without across flats

- Best length repeatability
- HF10: Fine grain carbide, 10% cobalt
- Central cooling

Artikel-Code Article-Code	D1 (h6) D1 (h6) [mm]	L (+ 1) L (+ 1) [mm]	Schnittstelle Interface	DKZ DKZ [mm]	Anzugsdrehmoment Tightening torque [Nm]	SW AF [mm]	Material Material
RODL10-D10HA0200-0001KZ	10	20	DL10	2	20	8	HF10
RODL12-D12HA0240-0001KZ	12	24	DL12	2	30	9,5	HF10
RODL16-D16HA0320-0001KZ	16	32	DL16	2	60	13	HF10
RODL20-D20HA0400-0001KZ	20	40	DL20	3	80	16	HF10
RODL25-D25HA0500-0001KZ	25	50	DL25	4	100	21	HF10
RODL32-D32HA0640-0001KZ	32	64	DL32	5	130	28	HF10

Weitere Längen und Längenmessvorrichtungen auf Anfrage/Further lengths and measuring devices available on request

Schlüsselweitenübersicht beachten. Nur mit Duo-Lock Torque Master verwenden. Mindestabstand zur Planfläche einhalten (Siehe Seite 189)
Pay attention to across flats overview. Use only with Duo-Lock Torque Master. Keep minimum length to plain surface (See page 189)

DUO-LOCK® ROHLING KÜHLBOHRUNG RADIAL 2X – OHNE SCHLÜSSELWEITE DUO-LOCK® BLANK COOLING BORE RADIAL 2X – WITHOUT ACROSS FLATS

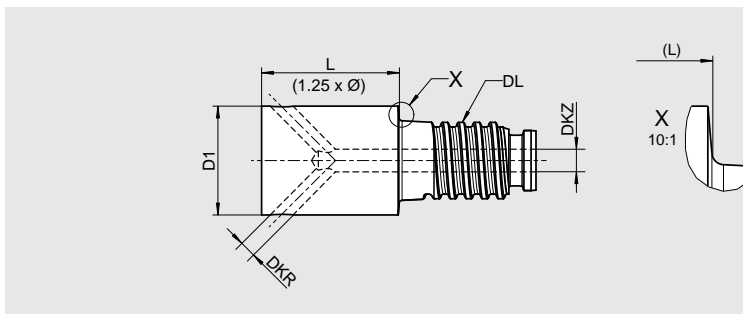

Ausführung: kurz, ohne Schlüsselweite

- Beste Längenwiederholgenauigkeit
- HF10: Feinstkorn-Hartmetall, 10% Kobalt
- Radiale Kühlung, 2 Kühlausstritte

Version: short, without across flats

- Best length repeatability
- HF10: Fine grain carbide, 10% cobalt
- Radial cooling, 2 cooling outlets

Artikel-Code Article-Code	D1 (h6) D1 (h6) [mm]	L (+ 1) L (+ 1) [mm]	Schnittstelle Interface	DKZ DKZ [mm]	DKR DKR [mm]	Kühlausstritte Cooling outlets	Drehmoment Torque [Nm]	SW AF [mm]	Material Material
RODL10-D10HA0125-0001KR02	10	12,5	DL10	2	1,4	2	20	8	HF10
RODL12-D12HA0150-0001KR02	12	15	DL12	2,5	1,75	2	30	9,5	HF10
RODL16-D16HA0200-0001KR02	16	20	DL16	3	2,1	2	60	13	HF10
RODL20-D20HA0250-0001KR02	20	25	DL20	3,5	2,45	2	80	16	HF10

Weitere Längen und Längenmessvorrichtungen auf Anfrage/Further lengths and measuring devices available on request

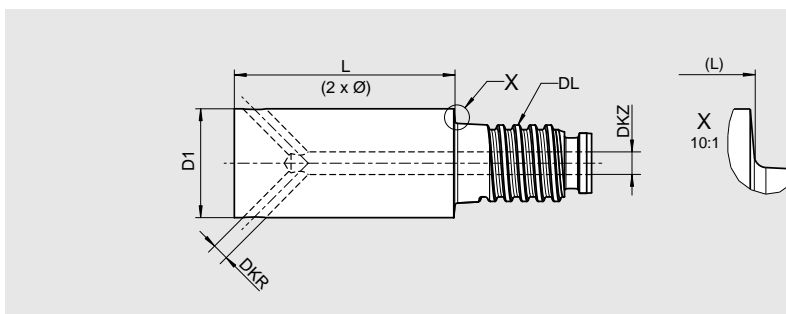

Ausführung: normal, ohne Schlüsselweite

- Beste Längenwiederholgenauigkeit
- HF10: Feinstkorn-Hartmetall, 10% Kobalt
- Radiale Kühlung, 2 Kühlausstritte

Version: normal, without across flats

- Best length repeatability
- HF10: Fine grain carbide, 10% cobalt
- Radial cooling, 2 cooling outlets

Artikel-Code Article-Code	D1 (h6) D1 (h6) [mm]	L (+ 1) L (+ 1) [mm]	Schnittstelle Interface	DKZ DKZ [mm]	DKR DKR [mm]	Kühlausstritte Cooling outlets	Drehmoment Torque [Nm]	SW AF [mm]	Material Material
RODL10-D10HA0200-0001KR02	10	20	DL10	2	1,4	2	20	8	HF10
RODL12-D12HA0240-0001KR02	12	24	DL12	2,5	1,75	2	30	9,5	HF10
RODL16-D16HA0320-0001KR02	16	32	DL16	3	2,1	2	60	13	HF10
RODL20-D20HA0400-0001KR02	20	40	DL20	3,5	2,45	2	80	16	HF10

Weitere Längen und Längenmessvorrichtungen auf Anfrage/Further lengths and measuring devices available on request

Schlüsselweitenübersicht beachten. Nur mit Duo-Lock Torque Master verwenden. Mindestabstand zur Planfläche einhalten (Siehe Seite 189)
Pay attention to across flats overview. Use only with Duo-Lock Torque Master. Keep minimum length to plain surface (See page 189)

DUO-LOCK® ROHLING KÜHLBOHRUNG RADIAL 3X – OHNE SCHLÜSSELWEITE

DUO-LOCK® BLANK COOLING BORE RADIAL 3X – WITHOUT ACROSS FLATS

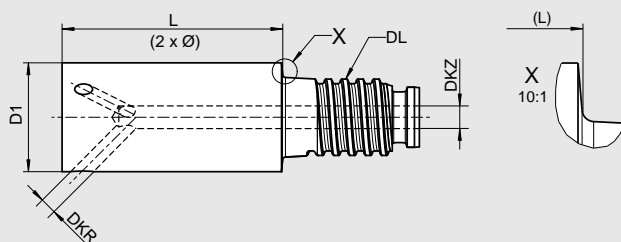

Ausführung: normal, ohne Schlüsselweite

- Beste Längenwiederholgenauigkeit
- HF10: Feinstkorn-Hartmetall, 10% Kobalt
- Radiale Kühlung, 3 Kühlaustritte

Version: normal, without across flats

- Best length repeatability
- HF10: Fine grain carbide, 10% cobalt
- Radial cooling, 3 cooling outlets

Artikel-Code Article-Code	D1 (h6) D1 (h6) [mm]	L (+ 1) L (+ 1) [mm]	Schnittstelle Interface	DKZ DKZ [mm]	DKR DKR [mm]	Kühlaustritte Cooling outlets	Drehmoment Torque [Nm]	SW AF [mm]	Material Material
RODL10-D10HA0200-0001KR03	10	20	DL10	2	1,15	3	20	8	HF10
RODL12-D12HA0240-0001KR03	12	24	DL12	2,5	1,4	3	30	9,5	HF10
RODL16-D16HA0320-0001KR03	16	32	DL16	3	1,7	3	60	13	HF10
RODL20-D20HA0400-0001KR03	20	40	DL20	3,5	2,0	3	80	16	HF10

Weitere Längen und Längenmessvorrichtungen auf Anfrage/Further lengths and measuring devices available on request

Schlüsselweitenübersicht beachten. Nur mit Duo-Lock Torque Master verwenden. Mindestabstand zur Planfläche einhalten (Siehe Seite 189)
Pay attention to across flats overview. Use only with Duo-Lock Torque Master. Keep minimum length to plain surface (See page 189)

DUO-LOCK® ROHLING KÜHLBOHRUNG RADIAL 4X – OHNE SCHLÜSSELWEITE DUO-LOCK® BLANK COOLING BORE RADIAL 4X – WITHOUT ACROSS FLATS

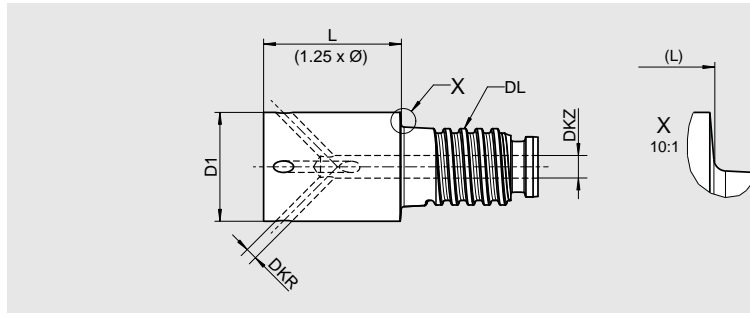

Ausführung: kurz, ohne Schlüsselweite

- Beste Längenwiederholgenauigkeit
- HF10: Feinstkorn-Hartmetall, 10% Kobalt
- Radiale Kühlung, 4 Kühlausstritte

Version: short, without across flats

- Best length repeatability
- HF10: Fine grain carbide, 10% cobalt
- Radial cooling, 4 cooling outlets

Artikel-Code Article-Code	D1 (h6) D1 (h6) [mm]	L (+ 1) L (+ 1) [mm]	Schnittstelle Interface	DKZ DKZ [mm]	DKR DKR [mm]	Kühlausstritte Cooling outlets	Drehmoment Torque [Nm]	SW AF [mm]	Material Material
RODL10-D10HA0125-0001KR04	10	12,5	DL10	2	1,0	4	20	8	HF10
RODL12-D12HA0150-0001KR04	12	15	DL12	2,5	1,25	4	30	9,5	HF10
RODL16-D16HA0200-0001KR04	16	20	DL16	3	1,5	4	60	13	HF10
RODL20-D20HA0250-0001KR04	20	25	DL20	3,5	1,75	4	80	16	HF10

Weitere Längen und Längenmessvorrichtungen auf Anfrage/Further lengths and measuring devices available on request

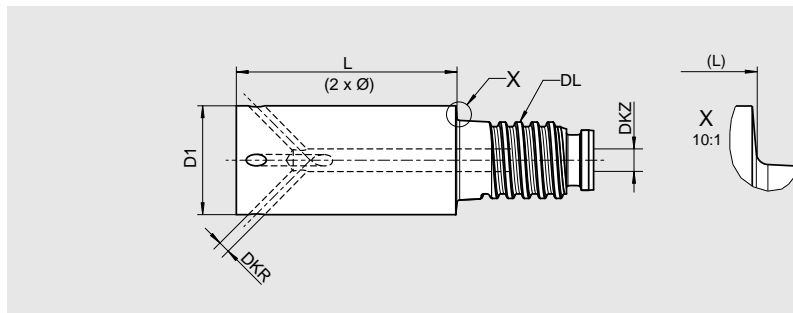

Ausführung: normal, ohne Schlüsselweite

- Beste Längenwiederholgenauigkeit
- HF10: Feinstkorn-Hartmetall, 10% Kobalt
- Radiale Kühlung, 4 Kühlausstritte

Version: normal, without across flats

- Best length repeatability
- HF10: Fine grain carbide, 10% cobalt
- Radial cooling, 4 cooling outlets

Artikel-Code Article-Code	D1 (h6) D1 (h6) [mm]	L (+ 1) L (+ 1) [mm]	Schnittstelle Interface	DKZ DKZ [mm]	DKR DKR [mm]	Kühlausstritte Cooling outlets	Drehmoment Torque [Nm]	SW AF [mm]	Material Material
RODL10-D10HA0200-0001KR04	10	20	DL10	2	1,0	4	20	8	HF10
RODL12-D12HA0240-0001KR04	12	24	DL12	2,5	1,25	4	30	9,5	HF10
RODL16-D16HA0320-0001KR04	16	32	DL16	3	1,5	4	60	13	HF10
RODL20-D20HA0400-0001KR04	20	40	DL20	3,5	1,75	4	80	16	HF10

Weitere Längen und Längenmessvorrichtungen auf Anfrage/Further lengths and measuring devices available on request

Schlüsselweitenübersicht beachten. Nur mit Duo-Lock Torque Master verwenden. Mindestabstand zur Planfläche einhalten (Siehe Seite 189)
Pay attention to across flats overview. Use only with Duo-Lock Torque Master. Keep minimum length to plain surface (See page 189)

DUO-LOCK® ROHLING KURZ – MIT SCHLÜSSELWEITE

DUO-LOCK® BLANK SHORT – WITH ACROSS FLATS

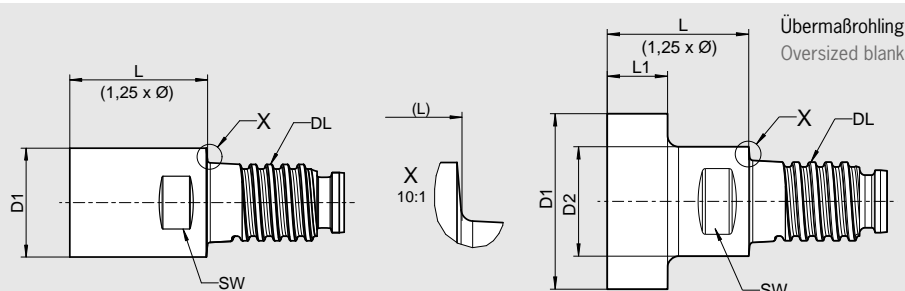

Ausführung: kurz, mit Schlüsselweite

- Beste Längenwiederholgenauigkeit
- HF10: Feinstkorn-Hartmetall, 10% Kobalt
- Zentrale Kühlung auf Anfrage erhältlich

Version: short, with across flats

- Best length repeatability
- HF10: Fine grain carbide, 10% cobalt
- Central cooling available upon request

Artikel-Code Article-Code	D1 (h6) D1 (h6) [mm]	D2 (-0,1) D2 (-0,1) [mm]	L (+ 1) L (+ 1) [mm]	L1 (+ 1) L1 (+ 1) [mm]	Schnittstelle Interface	Anzugsdrehmoment Tightening torque [Nm]	SW AF [mm]	Material Material
RODL10-D10HA0125-0002	10	–	12,5	–	DL10	20	8	HF10
RODL10-D12HA0125-0002	12	9,60	12,5	5,0	DL10	20	8	HF10
RODL10-D1270HA0125-0002	12,7	9,60	12,5	5	DL10	20	8	HF10
RODL10-D16HA0125-0002	16	9,60	12,5	5,0	DL10	20	8	HF10
RODL10-D20HA0125-0002	20	9,60	12,5	5,0	DL10	20	8	HF10
RODL12-D12HA0150-0002	12	–	15	–	DL12	30	9,5	HF10
RODL12-D1270HA0150-0002	12,7	–	15	–	DL12	30	9,5	HF10
RODL12-D16HA0150-0002	16	11,50	15	6,0	DL12	30	9,5	HF10
RODL12-D18HA0150-0002	18	11,50	15	6,0	DL12	30	9,5	HF10
RODL12-D20HA0150-0002	20	11,50	15	6,0	DL12	30	9,5	HF10
RODL12-D25HA0150-0002	25	11,50	15	6,0	DL12	30	9,5	HF10
RODL12-D2540HA0150-0002	25,4	11,50	15	6	DL12	30	9,5	HF10
RODL16-D16HA0200-0002	16	–	20	–	DL16	60	13	HF10
RODL16-D18HA0200-0002	18	15,50	20	8,0	DL16	60	13	HF10
RODL16-D20HA0200-0002	20	15,50	20	8,0	DL16	60	13	HF10
RODL16-D25HA0200-0002	25	15,50	20	8,0	DL16	60	13	HF10
RODL16-D2540HA0200-0002	25,4	15,50	20	8	DL16	60	13	HF10
RODL16-D32HA0200-0002	32	15,50	20	8,0	DL16	60	13	HF10
RODL20-D20HA0250-0002	20	–	25	–	DL20	80	16	HF10
RODL20-D25HA0250-0002	25	19,30	25	10,0	DL20	80	16	HF10
RODL20-D2540HA0250-0002	25,4	19,30	25	10	DL20	80	16	HF10
RODL20-D32HA0250-0002	32	19,30	25	10,0	DL20	80	16	HF10
RODL20-D36HA0250-0002	36	19,30	25	10,0	DL20	80	16	HF10
RODL20-D40HA0250-0002	40	19,30	25	10,0	DL20	80	16	HF10
RODL25-D25HA0313-0002	25	–	31,25	–	DL25	100	21	HF10
RODL25-D2540HA0313-0002	25,4	–	31,25	–	DL25	100	21	HF10
RODL32-D32HA0400-0002	32	–	40	–	DL32	130	28	HF10

Weitere Längen und Längenmessvorrichtungen auf Anfrage/Further lengths and measuring devices available on request

DUO-LOCK® ROHLING NORMAL – MIT SCHLÜSSELWEITE DUO-LOCK® BLANK NORMAL – WITH ACROSS FLATS

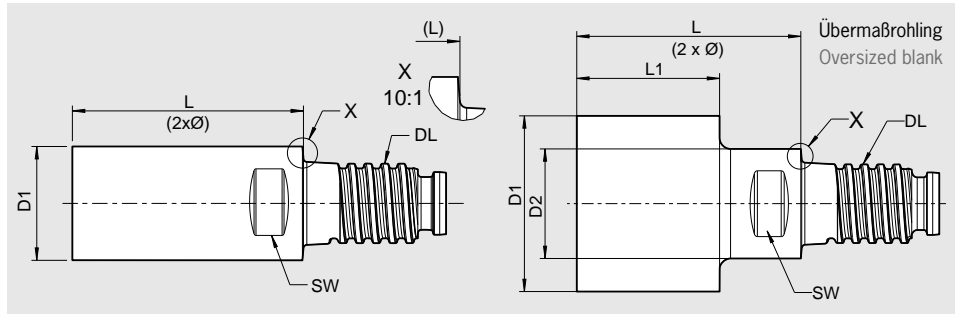

Ausführung: normal, mit Schlüsselweite

- Beste Längenwiederholgenauigkeit
- HF10: Feinstkorn-Hartmetall, 10% Kobalt
- Zentrale Kühlung auf Anfrage erhältlich

Version: normal, with across flats

- Best length repeatability
- HF10: Fine grain carbide, 10% cobalt
- Central cooling available upon request

Artikel-Code Article-Code	D1 (h6) D1 (h6) [mm]	D2 (-0,1) D2 (-0,1) [mm]	L (+ 1) L (+ 1) [mm]	L1 (+ 1) L1 (+ 1) [mm]	Schnittstelle Interface	Anzugsdrehmoment Tightening torque [Nm]	SW AF [mm]	Material Material
RODL10-D06HA0200-0002	6	9,60	20	16,0	DL10	20	8	HF10
RODL10-D0635HA0200-0002	6,4	9,60	20	16,0	DL10	20	8	HF10
RODL10-D08HA0200-0002	8	9,60	20	16,0	DL10	20	8	HF10
RODL10-D10HA0200-0002	10	-	20	-	DL10	20	8	HF10
RODL10-D12HA0200-0002	12	9,60	20	12,5	DL10	20	8	HF10
RODL10-D1270HA0200-0002	12,7	9,60	20	12,5	DL10	20	8	HF10
RODL10-D16HA0200-0002	16	9,60	20	12,5	DL10	20	8	HF10
RODL10-D20HA0200-0002	20	9,60	20	12,5	DL10	20	8	HF10
RODL12-D12HA0240-0002	12	-	24	-	DL12	30	9,5	HF10
RODL12-D1270HA0240-0002	12,7	-	24	-	DL12	30	9,5	HF10
RODL12-D16HA0240-0002	16	11,50	24	15,0	DL12	30	9,5	HF10
RODL12-D18HA0240-0002	18	11,50	24	15,0	DL12	30	9,5	HF10
RODL12-D20HA0240-0002	20	11,50	24	15,0	DL12	30	9,5	HF10
RODL12-D25HA0240-0002	25	11,50	24	15,0	DL12	30	9,5	HF10
RODL12-D2540HA0240-0002	25,4	11,50	24	15,0	DL12	30	9	HF10
RODL16-D16HA0320-0002	16	-	32	-	DL16	60	13	HF10
RODL16-D18HA0320-0002	18	15,50	32	20,0	DL16	60	13	HF10
RODL16-D20HA0320-0002	20	15,50	32	20,0	DL16	60	13	HF10
RODL16-D25HA0320-0002	25	15,50	32	20,0	DL16	60	13	HF10
RODL16-D2540HA0320-0002	25,4	15,50	32	20,0	DL16	60	13	HF10
RODL16-D32HA0320-0002	32	15,50	32	20,0	DL16	60	13	HF10
RODL20-D20HA0400-0002	20	-	40	-	DL20	80	16	HF10
RODL20-D25HA0400-0002	25	19,30	40	25,0	DL20	80	16	HF10
RODL20-D2540HA0400-0002	25,4	19,30	40	25,0	DL20	80	16	HF10
RODL20-D32HA0400-0002	32	19,30	40	25,0	DL20	80	16	HF10
RODL20-D36HA0400-0002	36	19,30	40	25,0	DL20	80	16	HF10
RODL20-D40HA0400-0002	40	19,30	40	25,0	DL20	80	16	HF10
RODL25-D25HA0500-0002	25	-	50	-	DL25	100	21	HF10
RODL25-D2540HA0500-0002	25,4	-	50	-	DL25	100	21	HF10
RODL32-D32HA0640-0002	32	-	64	-	DL32	130	28	HF10

Weitere Längen und Längenmessvorrichtungen auf Anfrage/Further lengths and measuring devices available on request

DUO-LOCK® ROHLING KÜHLBOHRUNG ZENTRAL – MIT SCHLÜSSELWEITE DUO-LOCK® BLANK COOLING BORE CENTRAL – WITH ACROSS FLATS

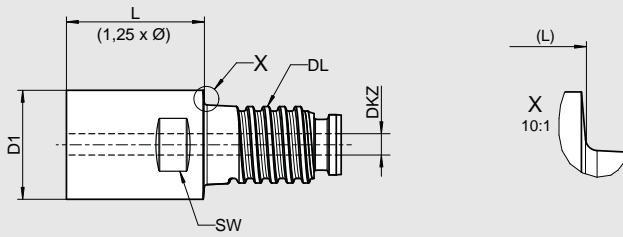

Ausführung: kurz, mit Schlüsselweite

- Beste Längenwiederholgenauigkeit
- HF10: Feinstkorn-Hartmetall, 10% Kobalt
- Zentrale Kühlung

Version: short, with across flats

- Best length repeatability
- HF10: Fine grain carbide, 10% cobalt
- Central cooling

Artikel-Code Article-Code	D1 (h6) D1 (h6) [mm]	L (+ 1) L (+ 1) [mm]	Schnittstelle Interface	DKZ DKZ [mm]	Anzugsdrehmoment Tightening torque [Nm]	SW AF [mm]	Material Material
RODL10-D10HA0125-0002KZ	10	12,5	DL10	2	20	8	HF10
RODL12-D12HA0150-0002KZ	12	15	DL12	2	30	9,5	HF10
RODL16-D16HA0200-0002KZ	16	20	DL16	2	60	13	HF10
RODL20-D20HA0250-0002KZ	20	25	DL20	3	80	16	HF10
RODL25-D25HA0313-0002KZ	25	31,25	DL25	4	100	21	HF10
RODL32-D32HA0400-0002KZ	32	40	DL32	5	130	28	HF10

Weitere Längen und Längenmessvorrichtungen auf Anfrage/Further lengths and measuring devices available on request

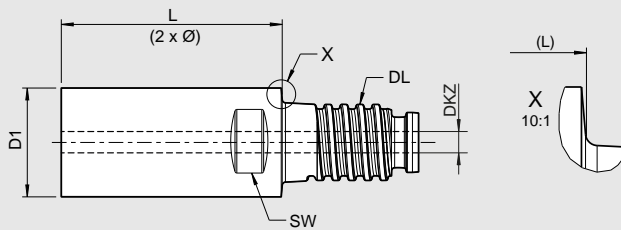

Ausführung: normal, mit Schlüsselweite

- Beste Längenwiederholgenauigkeit
- HF10: Feinstkorn-Hartmetall, 10% Kobalt
- Zentrale Kühlung

Version: normal, with across flats

- Best length repeatability
- HF10: Fine grain carbide, 10% cobalt
- Central cooling

Artikel-Code Article-Code	D1 (h6) D1 (h6) [mm]	L (+ 1) L (+ 1) [mm]	Schnittstelle Interface	DKZ DKZ [mm]	Anzugsdrehmoment Tightening torque [Nm]	SW AF [mm]	Material Material
RODL10-D10HA0200-0002KZ	10	20	DL10	2	20	8	HF10
RODL12-D12HA0240-0002KZ	12	24	DL12	2	30	9,5	HF10
RODL16-D16HA0320-0002KZ	16	32	DL16	2	60	13	HF10
RODL20-D20HA0400-0002KZ	20	40	DL20	3	80	16	HF10
RODL25-D25HA0500-0002KZ	25	50	DL25	4	100	21	HF10
RODL32-D32HA0640-0002KZ	32	64	DL32	5	130	28	HF10

Weitere Längen und Längenmessvorrichtungen auf Anfrage/Further lengths and measuring devices available on request

DUO-LOCK® ROHLING KÜHLBOHRUNG RADIAL 2X – MIT SCHLÜSSELWEITE DUO-LOCK® BLANK COOLING BORE RADIAL 2X – WITH ACROSS FLATS

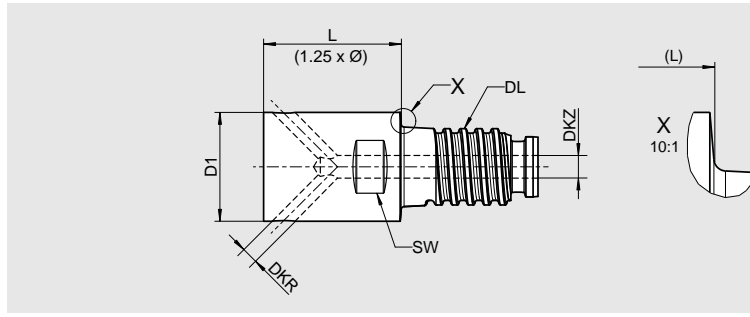

Ausführung: kurz, mit Schlüsselweite

- Beste Längenwiederholgenauigkeit
- HF10: Feinstkorn-Hartmetall, 10% Kobalt
- Radiale Kühlung, 2 Kühlausstritte

Version: short, with across flats

- Best length repeatability
- HF10: Fine grain carbide, 10% cobalt
- Radial cooling, 2 cooling outlets

Artikel-Code Article-Code	D1 (h6) D1 (h6) [mm]	L (+ 1) L (+ 1) [mm]	Schnittstelle Interface	DKZ DKZ [mm]	DKR DKR [mm]	Kühlausstritte Cooling outlets	Drehmoment Torque [Nm]	SW AF [mm]	Material Material
RODL10-D10HA0125-0002KR02	10	12,5	DL10	2	1,4	2	20	8	HF10
RODL12-D12HA0150-0002KR02	12	15	DL12	2,5	1,75	2	30	9,5	HF10
RODL16-D16HA0200-0002KR02	16	20	DL16	3	2,1	2	60	13	HF10
RODL20-D20HA0250-0002KR02	20	25	DL20	3,5	2,45	2	80	16	HF10

Weitere Längen und Längenmessvorrichtungen auf Anfrage/Further lengths and measuring devices available on request

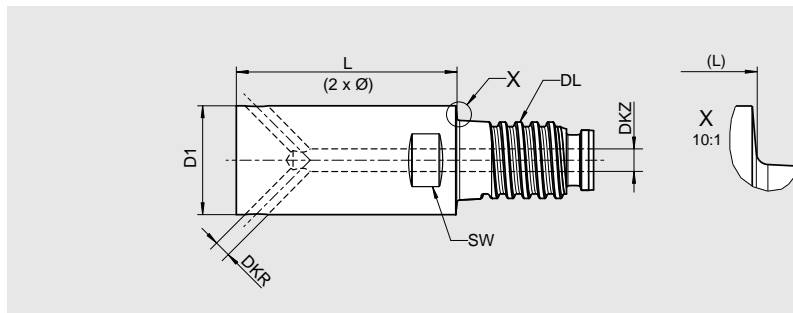

Ausführung: normal, ohne Schlüsselweite

- Beste Längenwiederholgenauigkeit
- HF10: Feinstkorn-Hartmetall, 10% Kobalt
- Radiale Kühlung, 2 Kühlausstritte

Version: normal, with across flats

- Best length repeatability
- HF10: Fine grain carbide, 10% cobalt
- Radial cooling, 2 cooling outlets

Artikel-Code Article-Code	D1 (h6) D1 (h6) [mm]	L (+ 1) L (+ 1) [mm]	Schnittstelle Interface	DKZ DKZ [mm]	DKR DKR [mm]	Kühlausstritte Cooling outlets	Drehmoment Torque [Nm]	SW AF [mm]	Material Material
RODL10-D10HA0200-0002KR02	10	20	DL10	2	1,4	2	20	8	HF10
RODL12-D12HA0240-0002KR02	12	24	DL12	2,5	1,75	2	30	9,5	HF10
RODL16-D16HA0320-0002KR02	16	32	DL16	3	2,1	2	60	13	HF10
RODL20-D20HA0400-0002KR02	20	40	DL20	3,5	2,45	2	80	16	HF10

Weitere Längen und Längenmessvorrichtungen auf Anfrage/Further lengths and measuring devices available on request

DUO-LOCK® ROHLING KÜHLBOHRUNG RADIAL 3X – MIT SCHLÜSSELWEITE

DUO-LOCK® BLANK COOLING BORE RADIAL 3X – WITH ACROSS FLATS

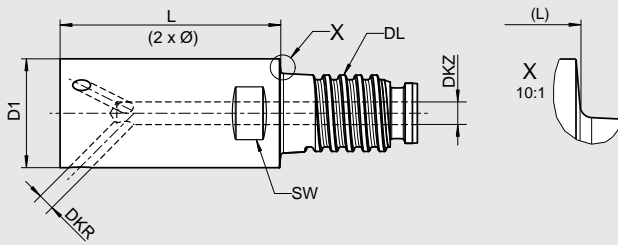

Ausführung: normal, mit Schlüsselweite

- Beste Längenwiederholgenauigkeit
- HF10: Feinstkorn-Hartmetall, 10% Kobalt
- Radiale Kühlung, 3 Kühlaustritte

Version: normal, with across flats

- Best length repeatability
- HF10: Fine grain carbide, 10% cobalt
- Radial cooling, 3 cooling outlets

Artikel-Code Article-Code	D1 (h6) D1 (h6) [mm]	L (+ 1) L (+ 1) [mm]	Schnittstelle Interface	DKZ DKZ [mm]	DKR DKR [mm]	Kühlaustritte Cooling outlets	Drehmoment Torque [Nm]	SW AF [mm]	Material Material
RODL10-D10HA0200-0002KR03	10	20	DL10	2	1,15	3	20	8	HF10
RODL12-D12HA0240-0002KR03	12	24	DL12	2,5	1,4	3	30	9,5	HF10
RODL16-D16HA0320-0002KR03	16	32	DL16	3	1,7	3	60	13	HF10
RODL20-D20HA0400-0002KR03	20	40	DL20	3,5	2,0	3	80	16	HF10

Weitere Längen und Längenmessvorrichtungen auf Anfrage/Further lengths and measuring devices available on request

DUO-LOCK® ROHLING KÜHLBOHRUNG RADIAL 4X – MIT SCHLÜSSELWEITE DUO-LOCK® BLANK COOLING BORE RADIAL 4X – WITH ACROSS FLATS

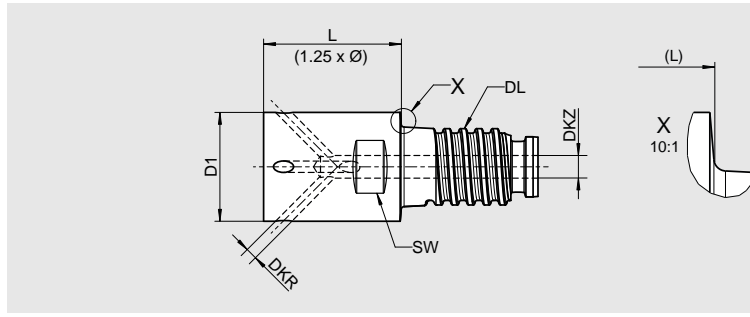

Ausführung: kurz, mit Schlüsselweite

- Beste Längenwiederholgenauigkeit
- HF10: Feinstkorn-Hartmetall, 10% Kobalt
- Radiale Kühlung, 4 Kühlausstritte

Version: short, with across flats

- Best length repeatability
- HF10: Fine grain carbide, 10% cobalt
- Radial cooling, 4 cooling outlets

Artikel-Code Article-Code	D1 (h6) D1 (h6) [mm]	L (+ 1) L (+ 1) [mm]	Schnittstelle Interface	DKZ DKZ [mm]	DKR DKR [mm]	Kühlausstritte Cooling outlets	Drehmoment Torque [Nm]	SW AF [mm]	Material Material
RODL10-D10HA0125-0002KR04	10	12,5	DL10	2	1,0	4	20	8	HF10
RODL12-D12HA0150-0002KR04	12	15	DL12	2,5	1,25	4	30	9,5	HF10
RODL16-D16HA0200-0002KR04	16	20	DL16	3	1,5	4	60	13	HF10
RODL20-D20HA0250-0002KR04	20	25	DL20	3,5	1,75	4	80	16	HF10

Weitere Längen und Längenmessvorrichtungen auf Anfrage/Further lengths and measuring devices available on request

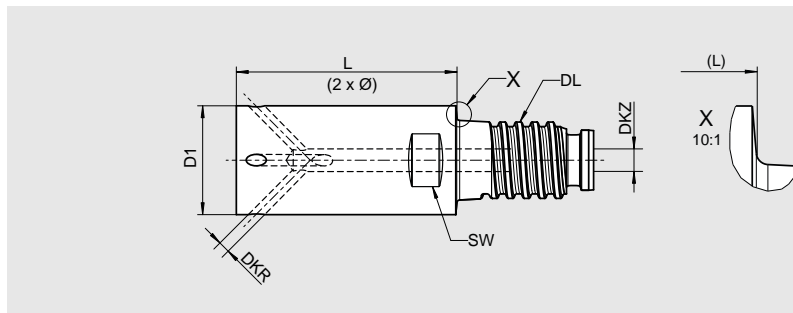

Ausführung: normal, mit Schlüsselweite

- Beste Längenwiederholgenauigkeit
- HF10: Feinstkorn-Hartmetall, 10% Kobalt
- Radiale Kühlung, 4 Kühlausstritte

Version: normal, with across flats

- Best length repeatability
- HF10: Fine grain carbide, 10% cobalt
- Radial cooling, 4 cooling outlets

Artikel-Code Article-Code	D1 (h6) D1 (h6) [mm]	L (+ 1) L (+ 1) [mm]	Schnittstelle Interface	DKZ DKZ [mm]	DKR DKR [mm]	Kühlausstritte Cooling outlets	Drehmoment Torque [Nm]	SW AF [mm]	Material Material
RODL10-D10HA0200-0002KR04	10	20	DL10	2	1,0	4	20	8	HF10
RODL12-D12HA0240-0002KR04	12	24	DL12	2,5	1,25	4	30	9,5	HF10
RODL16-D16HA0320-0002KR04	16	32	DL16	3	1,5	4	60	13	HF10
RODL20-D20HA0400-0002KR04	20	40	DL20	3,5	1,75	4	80	16	HF10

Weitere Längen und Längenmessvorrichtungen auf Anfrage/Further lengths and measuring devices available on request

DUO-LOCK® ROHLING – SCHLÜSSELWEITENVORGABE

DUO-LOCK® BLANK – ACROSS FLATS SPECIFICATIONS

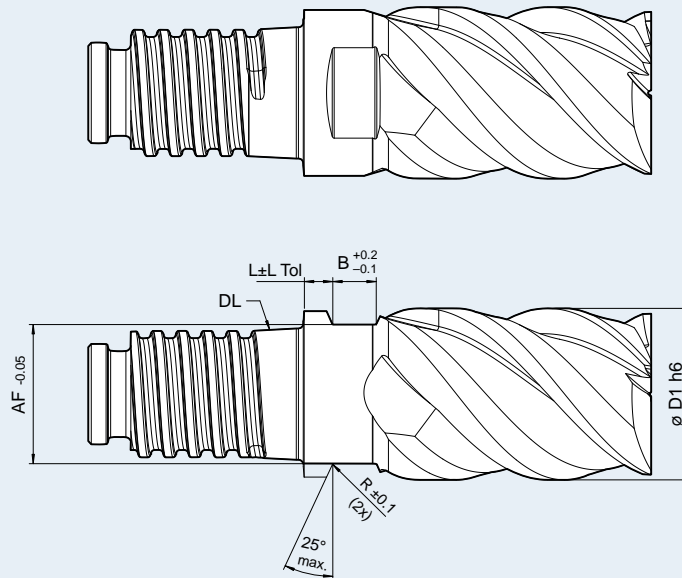

Schnittstelle Interface	SW AF [mm]	L L [mm]	L Tol. ± L Tol. ± [mm]	B B [mm]	ø D1 ø D1 [mm]	R R [mm]
DL10	8	1,7	± 0,15	2,5	10	0,3
DL12	9,5	2	± 0,15	3	12	0,3
DL16	13	2,5	± 0,2	4	16	0,3
DL20	16	3,1	± 0,2	4,8	20	0,3
DL25	21	3,5	± 0,2	7	25	0,6
DL32	28	4	± 0,2	9	32	0,6

DUO-LOCK® VERLÄNGERUNGEN – ZYLINDRISCH – KURZ – STAHL

DUO-LOCK® EXTENSIONS – CYLINDRICAL – SHORT – STEEL

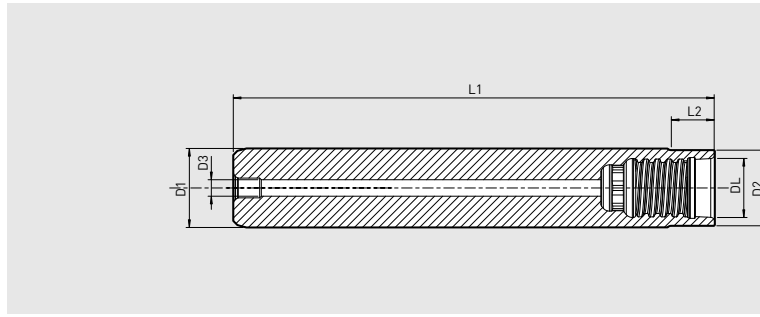

Ausführung: zylindrisch, kurz

- Schaftgenauigkeit: h6
- Mit Innenkühlbohrung
- Optional mit Safe-Lock

Zusätzlich erhältlich:

Verlängerungen in beschichteter Ausführung – für perfektes Ein- und Ausschrumpfen sogar bei großer Kräfteinwirkung bei der Bearbeitung

Version: cylindrical, short

- Shank tolerance: h6
- With inner coolant bore
- Optional with Safe-Lock

Also available:

Extensions with coating – for perfect shrinking in and out even at high forces during machining

Duo-Lock Verlängerungen zylindrisch: kurz/Duo-Lock extensions cylindrical: short

Schnittstelle Interface DL	Bestell-Nr. Order No.	Bestell-Nr. mit Beschichtung Order No. with Coating	Spann Ø Clamping Ø D1 [mm]	Länge Length L1 [mm]	Hals Ø Neck Ø D2 [mm]	Halslänge Neck length L2 [mm]	Innenbohrungs Ø Internal bore Ø D3 [mm]
DL12	75.120.DL12	75.120.DL12.1	12	60	11,5	6	2,5
DL16	75.160.DL16	75.160.DL16.1	16	65	15,5	8	3
DL20	75.200.DL20	75.200.DL20.1	20	70	19,3	10	3
DL25	75.250.DL25	75.250.DL25.1	25	80	24	12,5	5
DL32	75.320.DL32	75.320.DL32.1	32	90	31	16	5

Duo-Lock Verlängerungen zylindrisch: kurz mit Safe-Lock/Duo-Lock extensions cylindrical: short with Safe-Lock

Schnittstelle Interface DL	Bestell-Nr. Order No.	Bestell-Nr. mit Beschichtung Order No. with Coating	Spann Ø Clamping Ø D1 [mm]	Länge Length L1 [mm]	Hals Ø Neck Ø D2 [mm]	Halslänge Neck length L2 [mm]	Innenbohrungs Ø Internal bore Ø D3 [mm]
DL10	75.100.DL10	75.100.DL10.1	10	55	9,6	5	2,5
DL12	75.121.DL12	75.121.DL12.1	12	65	11,5	6	2,5
DL16	75.161.DL16	75.161.DL16.1	16	70	15,5	8	3
DL20	75.201.DL20	75.201.DL20.1	20	80	19,3	10	3
DL25	75.251.DL25	75.251.DL25.1	25	90	24	12,5	5
DL32	75.321.DL32	75.321.DL32.1	32	105	31	16	5

Drehmoment der Duo-Lock Schnittstelle/Torque of Duo-Lock interface

	DL10	DL12	DL16	DL20	DL25	DL32
Nm	20	30	60	80	100	130

Achtung: Für Langlebigkeit des Systems ist die Einhaltung des Drehmoments zwingend erforderlich
Attention: For long-life cycle of the system, compliance with the torque is required

DUO-LOCK® VERLÄNGERUNGEN – ZYLINDRISCH – LANG – STAHL

DUO-LOCK® EXTENSIONS – CYLINDRICAL – LONG – STEEL

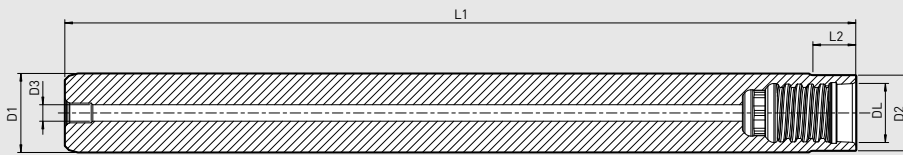

Ausführung: zylindrisch, lang

- Schaftgenauigkeit: h6
- mit Innenkühlbohrung
- Schwingungsdämpfung auf Anfrage
- Safe-Lock gegen Aufpreis möglich
- Ablängen gegen Aufpreis möglich

Zusätzlich erhältlich:

Verlängerungen in beschichteter Ausführung – für perfektes Ein- und Ausschumpfen sogar bei großer Kräfteinwirkung bei der Bearbeitung

Version: cylindrical, long

- Shank tolerance: h6
- With inner coolant bore
- Vibration dampening on request
- Safe-Lock for an extra charge
- Cutting to length possible for an extra charge

Also available:

Extensions with coating – for perfect shrinking in and out even at high forces during machining

Duo-Lock Verlängerungen zylindrisch: lang/Duo-Lock extensions cylindrical: long

Schnittstelle Interface DL	Bestell-Nr. Order No.	Bestell-Nr. mit Beschichtung Order No. with Coating	Spann Ø Clamping Ø D1 [mm]	Länge Length L1 [mm]	Hals Ø Neck Ø D2 [mm]	Halslänge Neck length L2 [mm]	Innenbohrungs Ø Internal bore Ø D3 [mm]
DL10	75.102.DL10	75.102.DL10.1	10	100	9,6	5	2,5
DL12	75.122.DL12	75.122.DL12.1	12	120	11,5	6	2,5
DL16	75.162.DL16	75.162.DL16.1	16	160	15,5	8	3
DL20	75.202.DL20	75.202.DL20.1	20	200	19,3	10	3
DL25	75.252.DL25	75.252.DL25.1	25	250	24	12,5	5
DL32	75.322.DL32	75.322.DL32.1	32	250	31	16	5

Drehmoment der Duo-Lock Schnittstelle/Torque of Duo-Lock interface

	DL10	DL12	DL16	DL20	DL25	DL32
Nm	20	30	60	80	100	130

Achtung: Für Langlebigkeit des Systems ist die Einhaltung des Drehmoments zwingend erforderlich

Attention: For long-life cycle of the system, compliance with the torque is required

DUO-LOCK® VERLÄNGERUNGEN KONISCH – KURZ – STAHL

DUO-LOCK® EXTENSIONS CONICAL – SHORT – STEEL

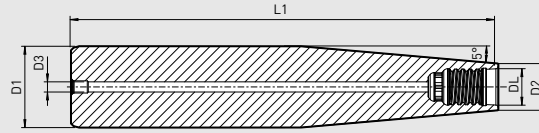

Ausführung: konisch, kurz

- Schaftgenauigkeit: h6
- Mit Innenkühlbohrung
- Standardmäßig mit Safe-Lock

Zusätzlich erhältlich:

Verlängerungen in beschichteter Ausführung – für perfektes Ein- und Ausschrumpfen sogar bei großer Kräfteinwirkung bei der Bearbeitung

Version: conical, short

- Shank tolerance: h6
- With inner coolant bore
- With Safe-Lock as standard

Also available:

Extensions with coating – for perfect shrinking in and out even at high forces during machining

Duo-Lock Verlängerungen konisch: kurz mit Safe-Lock/Duo-Lock extensions conical: short with Safe-Lock

Schnittstelle Interface DL	Bestell-Nr. Order No.	Bestell-Nr. mit Beschichtung Order No. with coating	Spann Ø Clamping Ø D1 [mm]	Länge Length L1 [mm]	Außen Ø Outer Ø D2 [mm]	Innenbohrungs Ø Internal bore Ø D3 [mm]
DL10	75.120.DL10	75.120.DL10.1	12	65	9,6	2,5
DL10	75.160.DL10	75.160.DL10.1	16	90	9,6	2,5
DL10	75.200.DL10	75.200.DL10.1	20	115	9,6	2,5
DL12	75.160.DL12	75.160.DL12.1	16	80	11,5	2,5
DL12	75.200.DL12	75.200.DL12.1	20	105	11,5	2,5
DL16	75.200.DL16	75.200.DL16.1	20	80	15,5	3
DL16	75.250.DL16	75.250.DL16.1	25	115	15,5	3
DL20	75.250.DL20	75.250.DL20.1	25	95	19,3	3
DL25	75.320.DL25	75.320.DL25.1	32	105	24	5
DL32	75.400.DL32	75.400.DL32.1	40	140	31	5
DL32	75.500.DL32	75.500.DL32.1	50	200	31	5

Drehmoment der Duo-Lock Schnittstelle/Torque of Duo-Lock interface

	DL10	DL12	DL16	DL20	DL25	DL32
Nm	20	30	60	80	100	130

Achtung: Für Langlebigkeit des Systems ist die Einhaltung des Drehmoments zwingend erforderlich

Attention: For long-life cycle of the system, compliance with the torque is required

DUO-LOCK® VERLÄNGERUNGEN KONISCH – LANG – STAHL

DUO-LOCK® EXTENSIONS CONICAL – LONG – STEEL

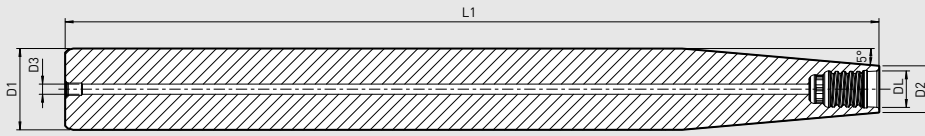

Ausführung: konisch, lang

- Schaftgenauigkeit: h6
- mit Innenkühlbohrung
- Schwingungsdämpfung auf Anfrage
- Safe-Lock gegen Aufpreis möglich
- Ablängen gegen Aufpreis möglich

Zusätzlich erhältlich:

Verlängerungen in beschichteter Ausführung – für perfektes Ein- und Ausschrumpfen sogar bei großer Kräfteinwirkung bei der Bearbeitung

Version: conical, long

- Shank tolerance: h6
- With inner coolant bore
- Vibration dampening on request
- Safe-Lock for an extra charge
- Cutting to length possible for an extra charge

Also available:

Extensions with coating – for perfect shrinking in and out even at high forces during machining

Duo-Lock Verlängerungen konisch: lang/Duo-Lock extensions conical: long

Schnittstelle Interface DL	Bestell-Nr. Order No.	Bestell-Nr. mit Beschichtung Order No. with coating	Spann Ø Clamping Ø D1 [mm]	Länge Length L1 [mm]	Außen Ø Outer Ø D2 [mm]	Innenbohrung Ø Internal bore Ø D3 [mm]
DL10	75.122.DL10	75.122.DL10.1	12	120	9,6	2,5
DL10	75.162.DL10	75.162.DL10.1	16	160	9,6	2,5
DL10	75.202.DL10	75.202.DL10.1	20	200	9,6	2,5
DL12	75.162.DL12	75.162.DL12.1	16	160	11,5	2,5
DL12	75.202.DL12	75.202.DL12.1	20	200	11,5	2,5
DL16	75.202.DL16	75.202.DL16.1	20	200	15,5	3
DL16	75.252.DL16	75.252.DL16.1	25	250	15,5	3
DL20	75.252.DL20	75.252.DL20.1	25	250	19,3	3
DL25	75.322.DL25	75.322.DL25.1	32	250	24	5
DL32	75.402.DL32	75.402.DL32.1	40	250	31	5
DL32	75.502.DL32	75.502.DL32.1	50	250	31	5

Drehmoment der Duo-Lock Schnittstelle/Torque of Duo-Lock interface

	DL10	DL12	DL16	DL20	DL25	DL32
Nm	20	30	60	80	100	130

Achtung: Für Langlebigkeit des Systems ist die Einhaltung des Drehmoments zwingend erforderlich

Attention: For long-life cycle of the system, compliance with the torque is required

DUO-LOCK® VERLÄNGERUNGEN SCHWERMETALL DUO-LOCK® EXTENSIONS HEAVY METAL

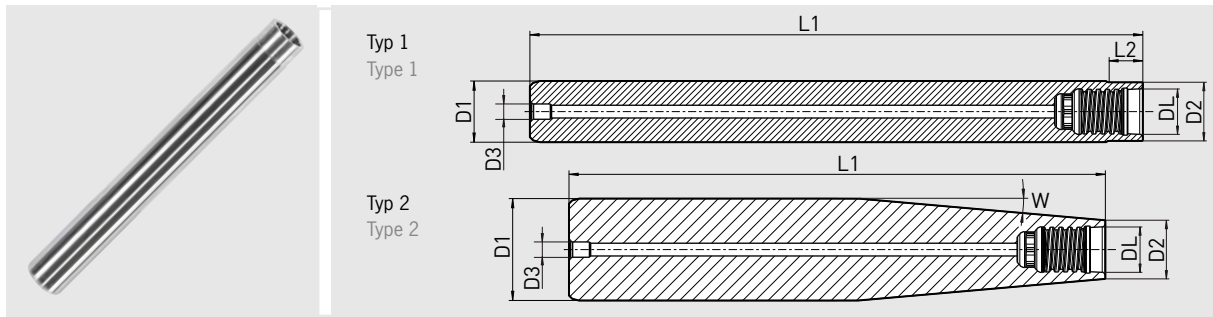

Ausführung: Schwermetall

- L1, L2 und Winkel W frei wählbar
- Schaftgenauigkeit: h6
- mit Innenkühlbohrung
- Optional mit Safe-Lock

Version: Heavy metal

- Free choice of L1, L2 and angle W
- Shank tolerance: h6
- With inner coolant bore
- Optional with Safe-Lock

Schnittstelle Interface DL	Bestell-Nr. Order No.	Spann Ø Clamping Ø D1 [mm]	Länge max. Length max. L1 [mm]	Innenbohrungs Ø Internal bore D3 [mm]
DL10	75.109.DL10.4.XXX.XXX	10	150	2,5
DL10 - DL12	75.129.DLXX.4.XXX.XXX	12	180	2,5
DL10 - DL16	75.169.DLXX.4.XXX.XXX	16	240	3
DL10 - DL20	75.209.DLXX.4.XXX.XXX	20	260	3
DL10 - DL25	75.259.DLXX.4.XXX.XXX	25	260	3
DL10 - DL32	75.329.DLXX.4.XXX.XXX	32	260	5
DL10 - DL32	75.409.DLXX.4.XXX.XXX	40	260	5
DL10 - DL32	75.509.DLXX.4.XXX.XXX	50	260	5

Drehmoment der Duo-Lock Schnittstelle/Torque of Duo-Lock interface

	DL10	DL12	DL16	DL20	DL25	DL32
Nm	15	25	40	60	90	130

Achtung: Für Langlebigkeit des Systems ist die Einhaltung des Drehmoments zwingend erforderlich.

Die Drehmomentangabe ist auf der Verlängerung angegeben.

Attention: For long-life cycle of the system, compliance with the torque is required.

The torque specification is given on the extension.

Schnittstelle Interface DL	Fix Ø Fix Ø D2 [mm]	Standard Standard L2 [mm]
DL10	9,6	5
DL12	11,5	6
DL16	15,5	8
DL20	19,3	10
DL25	24	12,5
DL32	31	16

Erklärung Bestell-Nr. / Legend Order No.:

75.XX9.DLXX.4.XXX.XXX

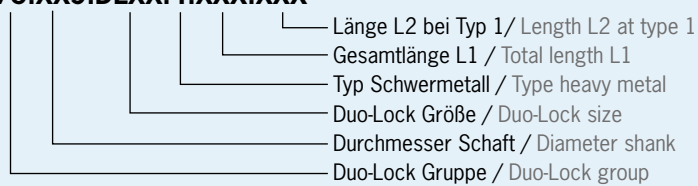

DUO-LOCK® VERLÄNGERUNGEN HARTMETALL

DUO-LOCK® EXTENSIONS CARBIDE

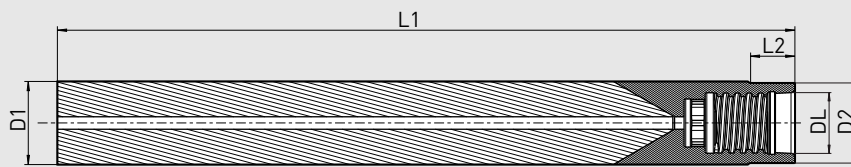

Ausführung: Hartmetall

- Schaftgenauigkeit: h6
- Mit Innenkühlbohrung
- Optional mit Safe-Lock
- Individuell: L1 und L2 frei wählbar

Version: Carbide

- Shank tolerance: h6
- With inner coolant bore
- Optional with Safe-Lock
- Customized: Free choice of L1, L2

Duo-Lock Verlängerungen Hartmetall: Standard/Duo-Lock extension solid carbide: standard

Schnittstelle Interface DL	Bestell-Nr. Order No.	Spann Ø Clamping Ø D1 [mm]	Länge Length L1 [mm]	Fix Ø Fix Ø D2 [mm]	Länge Length L2 [mm]
DL10	75.109.DL10.5.0775.0375	10	77,5	9,6	37,5
DL10	75.109.DL10.5.150.005	10	150	9,6	5
DL12	75.129.DL12.5.070.030	12	70	11,5	30
DL12	75.129.DL12.5.093.045	12	93	11,5	45
DL12	75.129.DL12.5.180.006	12	180	11,5	6
DL16	75.169.DL16.5.090.042	16	90	15,5	42
DL16	75.169.DL16.5.108.060	16	108	15,5	60
DL16	75.169.DL16.5.240.008	16	240	15,5	8
DL20	75.209.DL20.5.090.045	20	90	19,3	45
DL20	75.209.DL20.5.125.075	20	125	19,3	75
DL20	75.209.DL20.5.260.010	20	260	19,3	10
DL25	75.259.DL25.5.120.050	25	120	24	50
DL25	75.259.DL25.5.165.09375	25	165	24	93,75
DL25	75.259.DL25.5.260.0125	25	260	24	12,5
DL32	75.329.DL32.5.130.070	32	130	31	70
DL32	75.329.DL32.5.180.120	32	180	31	120
DL32	75.329.DL32.5.260.016	32	260	31	16

Duo-Lock Verlängerungen Hartmetall: Individuell/Duo-Lock extension solid carbide: customized

Schnittstelle Interface DL	Bestell-Nr. Order No.	Spann Ø Clamping Ø D1 [mm]	Länge max. Length max. L1 [mm]	Fix Ø Fix Ø D2 [mm]	Standard Standard L2 [mm]
DL10	75.109.DL10.5.XXX.XXX	10	150	9,6	5
DL12	75.129.DL12.5.XXX.XXX	12	180	11,5	6
DL16	75.169.DL16.5.XXX.XXX	16	240	15,5	8
DL20	75.209.DL20.5.XXX.XXX	20	260	19,3	10
DL25	75.259.DL25.5.XXX.XXX	25	260	24	12,5
DL32	75.329.DL32.5.XXX.XXX	32	260	31	16

Erklärung Bestell-Nr. / Legend Order No.:

75.XX9.DLXX.5.XXX.XXX

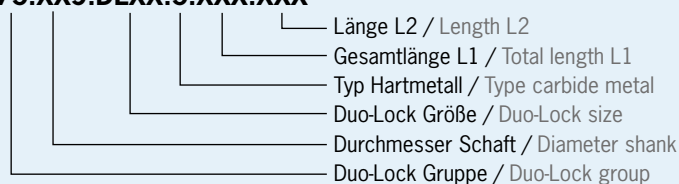

Drehmoment der Duo-Lock Schnittstelle/Torque of Duo-Lock interface

	DL10	DL12	DL16	DL20	DL25	DL32
Nm	20	30	60	80	100	130

Achtung: Für Langlebigkeit des Systems ist die Einhaltung des Drehmoments zwingend erforderlich
 Attention: For long-life cycle of the system, compliance with the torque is required

DUO-LOCK® VERLÄNGERUNGEN HEAVY DUTY – STAHL DUO-LOCK® EXTENSIONS HEAVY DUTY – STEEL

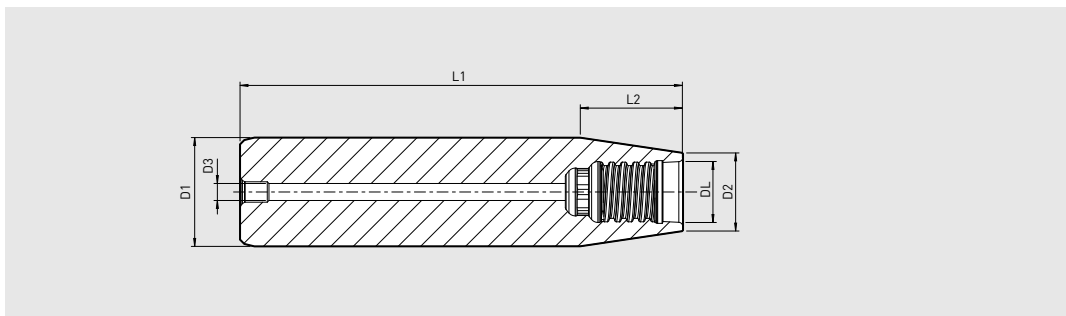

Ausführung: Heavy Duty

- Schaftgenauigkeit: h6
- Mit Innenkühlbohrung
- Standardmäßig mit Safe-Lock

Zusätzlich erhältlich:

Verlängerung in beschichteter Ausführung – für perfektes Ein- und Ausschrupfen sogar bei großer Kräfteinwirkung bei der Bearbeitung

Version: Heavy Duty

- Shank tolerance: h6
- With inner coolant bore
- With Safe-Lock as standard

Also available:

Extension with coating – for perfect shrinking in and out even at high forces during machining

Duo-Lock Verlängerungen Heavy Duty mit Safe-Lock/Duo-Lock extensions Heavy Duty with Safe-Lock

Schnittstelle Interface DL	Bestell-Nr. Order No.	Spann Ø Clamping Ø D1 [mm]	Länge Length L1 [mm]	Länge Length L2 [mm]	Außen Ø Outer Ø D2 [mm]	Innenbohrungs Ø Internal bore Ø D3 [mm]
DL10	75.160.DL10.9	16	62,5	12,5	9,6	2,5
DL12	75.160.DL12.9	16	65	15	11,5	2,5
DL16	75.200.DL16.9	20	72	20	15,5	3
DL20	75.250.DL20.9	25	82	24	19,3	3

Drehmoment der Duo-Lock Schnittstelle/Torque of Duo-Lock interface

	DL10	DL12	DL16	DL20	DL25	DL32
Nm	20	30	60	80	100	130

Achtung: Für Langlebigkeit des Systems ist die Einhaltung des Drehmoments zwingend erforderlich
Attention: For long-life cycle of the system, compliance with the torque is required

DUO-LOCK® VERLÄNGERUNGEN HEAVY DUTY MIT COOL JET – STAHL

DUO-LOCK® EXTENSIONS HEAVY DUTY WITH COOL JET – STEEL

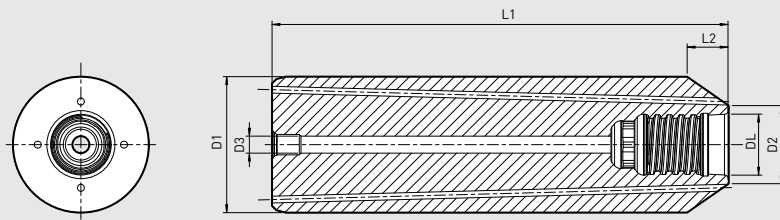

Ausführung: Heavy Duty mit Cool Jet

- Schaftgenauigkeit: h6
- Mit Cool Jet
- Standardmäßig mit Safe-Lock

Zusätzlich erhältlich:

Verlängerung in beschichteter Ausführung – für perfektes Ein- und Ausschumpfen sogar bei großer Krafteinwirkung bei der Bearbeitung

Version: Heavy Duty with Cool Jet

- Shank tolerance: h6
- With Cool Jet
- With Safe-Lock as standard

Also available:

Extension with coating – for perfect shrinking in and out even at high forces during machining

Duo-Lock Verlängerungen Heavy Duty mit Cool Jet/Duo-Lock extensions Heavy Duty with Cool Jet

Schnittstelle Interface DL	Bestell-Nr. Order No.	Spann Ø Clamping Ø D1 [mm]	Länge Length L1 [mm]	Länge Length L2 [mm]	Außen Ø Outer Ø D2 [mm]	Innenbohrungs Ø Internal bore Ø D3 [mm]
DL10	75.160.DL10.82	16	62,5	6	9,6	2,5
DL12	75.200.DL12.82	20	67	6	11,5	2,5
DL16	75.250.DL16.82	25	78	6	15,5	3
DL20	75.320.DL20.82	32	82	6	19,3	3

Drehmoment der Duo-Lock Schnittstelle/Torque of Duo-Lock interface

	DL10	DL12	DL16	DL20	DL25	DL32
Nm	20	30	60	80	100	130

Achtung: Für Langlebigkeit des Systems ist die Einhaltung des Drehmoments zwingend erforderlich
Attention: For long-life cycle of the system, compliance with the torque is required

DUO-LOCK® HARTMETALL/STAHL VERLÄNGERUNG DUO-LOCK® CARBIDE/STEEL EXTENSION

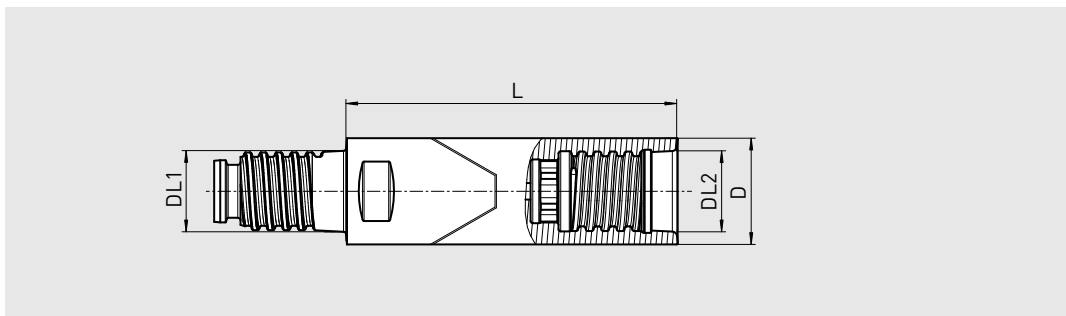

Zylindrische Hartmetall/Stahl Duo-Lock Verlängerung zum schnellen und effektiven Erreichen von Kavitäten.

Cylindrical carbide / steel Duo-Lock extension for fast and effective reaching of cavities.

– Mit Durchgangsbohrung für Innenkühlung

– With inner coolant bore

Duo-Lock Verlängerung zum Einschrauben/Duo-Lock extension for extension

Schnittstelle DL1 Interface DL1	Bestell-Nr. Order No.	Schnittstelle DL2 Interface DL2	Außen ø D [mm] Outer ø D [mm]	Länge L [mm] Length L [mm]
DL10	75.DL10.DL10.030	DL10	9,6	30
DL12	75.DL12.DL12.040	DL12	11,5	40
DL16	75.DL16.DL16.050	DL16	15,5	50
DL20	75.DL20.DL20.060	DL20	19,3	60

Drehmoment der Duo-Lock Schnittstelle/Torque of Duo-Lock interface

	DL10	DL12	DL16	DL20
Nm	20	30	60	80

Achtung: Für Langlebigkeit des Systems ist die Einhaltung des Drehmoments zwingend erforderlich

Attention: For long-life cycle of the system, compliance with the torque is required

DUO-LOCK® HARTMETALL/STAHL REDUZIERUNG DUO-LOCK® CARBIDE/STEEL REDUCTION

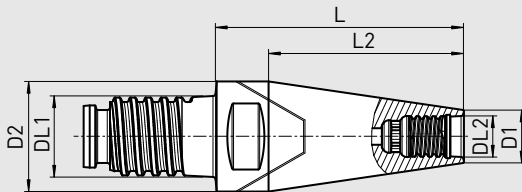

Zylindrische Hartmetall/Stahl Duo-Lock Reduzierung zum schnellen und effektiven Erreichen von Kavitäten.

Cylindrical carbide / steel Duo-Lock reduction for fast and effective reaching of cavities.

- Mit Durchgangsbohrung für Innenkühlung
- Außenkonturanpassung (L2) gegen Aufpreis möglich (Sonderanfrage)

- With inner coolant bore
- External contour adaptation (L2) possible for an extra charge (special request)

Duo-Lock Reduzierung zum Einschrauben/Duo-Lock reduction for extension

Schnittstelle DL1 Interface DL1	Bestell-Nr. Order No.	Schnittstelle DL2 Interface DL2	Außen Ø D1 [mm] Outer Ø D1 [mm]	Außen Ø D2 [mm] Outer Ø D2 [mm]	Länge L [mm] Length L [mm]
DL12	75.DL12.DL10.030	DL10	9,6	11,5	30
DL16	75.DL16.DL10.035	DL10	9,6	15,5	35
DL16	75.DL16.DL12.035	DL12	11,5	15,5	35
DL20	75.DL20.DL10.045	DL10	9,6	19,3	45
DL20	75.DL20.DL12.045	DL12	11,5	19,3	45
DL20	75.DL20.DL16.045	DL16	15,5	19,3	45

Drehmoment der Duo-Lock Schnittstelle/Torque of Duo-Lock interface

	DL10	DL12	DL16	DL20
Nm	20	30	60	80

Achtung: Für Langlebigkeit des Systems ist die Einhaltung des Drehmoments zwingend erforderlich
Attention: For long-life cycle of the system, compliance with the torque is required

DUO-LOCK® SPANNZANGEN DUO-LOCK® COLLETS

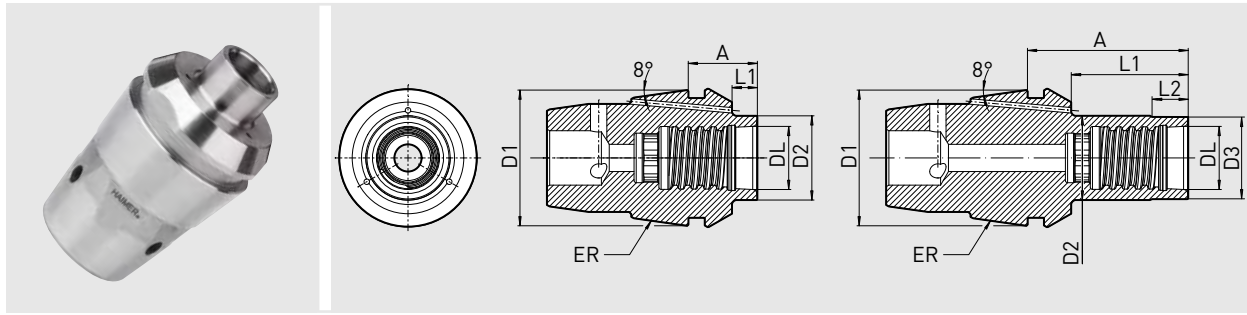

- Passend für Duo-Lock Fräser von DL10 – DL25
- Kompatibel mit allen gängigen ER-Spannzangensystemen
- Optional mit Cool Jet 3 oder 6 Bohrungen
- Zubehör siehe Seite 212

- Useable for Duo-Lock milling heads from DL10 – DL25
- Compatible with all established ER systems
- Optional with Cool Jet 3 or 6 bores
- Accessories see page 212

Duo-Lock Spannzangen/Duo-Lock collets

Bestell-Nr. Order No.	ER Größe ER Size	Nenn Ø Nominal Ø D1 [mm]	Länge Length A [mm]	Länge Length L1 [mm]	Länge Length L2 [mm]	Außen Ø Outer Ø D2 [mm]	Hals Ø Neck Ø D3 [mm]	Duo-Lock Größe Duo-Lock Size DL
81.160.0120.DL10	ER16	16	12	5,3	-	9,6	-	DL10
81.200.0130.DL10	ER20	20	13	5,48	-	9,6	-	DL10
81.200.0140.DL12	ER20	20	14	6,48	-	11,5	-	DL12
81.250.0135.DL10	ER25	25	13,5	5,5	-	9,6	-	DL10
81.250.0145.DL12	ER25	25	14,5	6,5	-	11,5	-	DL12
81.250.0135.DL16	ER25	25	13,5	5,5	-	15,5	-	DL16
81.320.0140.DL10	ER32	32	14	5	-	9,6	-	DL10
81.320.0355.DL10	ER32	32	35,5	26,5	5	10	9,6	DL10
81.320.0150.DL12	ER32	32	15	6	-	11,5	-	DL12
81.320.0365.DL12	ER32	32	36,5	27,5	6	12	11,5	DL12
81.320.0170.DL16	ER32	32	17	8	-	15,5	-	DL16
81.320.0355.DL16	ER32	32	35,5	26,5	8	16	15,5	DL16
81.320.0190.DL20	ER32	32	19	10	-	19,3	-	DL20
81.320.0355.DL20	ER32	32	35,5	26,5	10	20	19,3	DL20
81.320.0215.DL25	ER32	32	21,5	12,5	-	24	-	DL25
81.320.0407.DL25	ER32	32	40,75	31,75	-	24	-	DL25

Drehmoment der Duo-Lock Schnittstelle/Torque of Duo-Lock interface

	DL10	DL12	DL16	DL20	DL25	DL32
Nm	20	30	60	80	100	130

Achtung: Für Langlebigkeit des Systems ist die Einhaltung des Drehmoments zwingend erforderlich
Attention: For long-life cycle of the system, compliance with the torque is required

Zubehör/Accessories

Cool Jet mit 3 Kühlkanalbohrungen/Cool Jet with 3 coolant bores
Bestell-Nr./Order No. 91.100.25

Cool Jet mit 6 Kühlkanalbohrungen/Cool Jet with 6 coolant bores
Bestell-Nr./Order No. 91.100.31



Alternativ empfehlen wir den Einsatz unserer Schrumpfspannzangen für angetriebene Werkzeuge.
Siehe hierzu Zubehör ab Seite 732.
Alternatively we recommend to use our shrink fit collets in driven tools.
See accessories from page 732.

DUO-LOCK® MONOBLOCKAUFNAHME DUO-LOCK® MONOBLOCK HOLDER DIN 69871 · SK40

QUALITÄTSPASS
<ul style="list-style-type: none"> ✓ Aufnahmekörper feingewuchtet ✓ Chuck body fine balanced G2.5 25.000 1/min oder/or U<1 gmm
<ul style="list-style-type: none"> ✓ Alle Funktionsflächen feinbearbeitet ✓ All functional surfaces fine machined
<ul style="list-style-type: none"> ✓ Kegeltoleranz AT3 ✓ Taper tolerance AT3
<ul style="list-style-type: none"> ✓ Kühlmittelzufuhr Form AD/AF ✓ Coolant supply form AD/AF

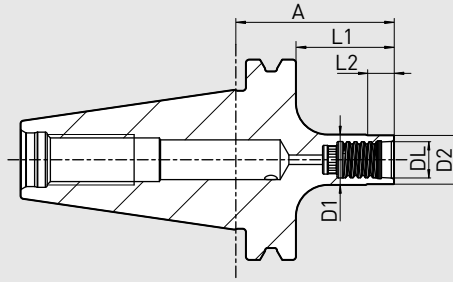

Duo-Lock Monoblockaufnahme für direkte Spannung.
Perfekt geeignet für das Fräsen mit kurzer Auskraglänge.

Duo-Lock Monoblock holder for direct clamping.
Perfectly suitable for milling with short overhang.

Mit Steilkegel SK40 Form AD/AF DIN ISO 7388-1 (vormals DIN 69871).

With taper SK40 form AD/AF DIN ISO 7388-1 (previously DIN 69871).

Form AD/AF bedeutet: zentrale Kühlmittelzufuhr und wiedererschließbare Kühlmittelkanäle am Bund.

Form AD/AF means: central coolant supply and coolant channels on the collar which can be sealed again.

- Alle Aufnahmen inkl. Innenkühlung
- Gehärtet 54-2 HRC

- All holders incl. inner coolant
- Hardened 54-2 HRC

SK40

Schnittstelle/Interface	DL10	DL12	DL16	DL20	DL25	DL32
∅ D1 [mm]	10	12	16	20	25	32
∅ D2 [mm]	9,6	11,5	15,5	19,3	24	31
L1 [mm]	21,9	21,9	30,9	30,9	36,9	45,9
L2 [mm]	5	6	8	10	12,5	16
Maß/Length A [mm] kurz/short	41	41	50	50	56	65
Bestell-Nr./Order No. 40.490.DL...	10	12	16	20	25	32

Drehmoment der Duo-Lock Schnittstelle/Torque of Duo-Lock interface						
	DL10	DL12	DL16	DL20	DL25	DL32
Nm	20	30	60	80	100	130

Achtung: Für Langlebigkeit des Systems ist die Einhaltung des Drehmoments zwingend erforderlich
Attention: For long-life cycle of the system, compliance with the torque is required

DUO-LOCK® MONOBLOCKAUFNAHME DUO-LOCK® MONOBLOCK HOLDER DIN 69871 · SK50

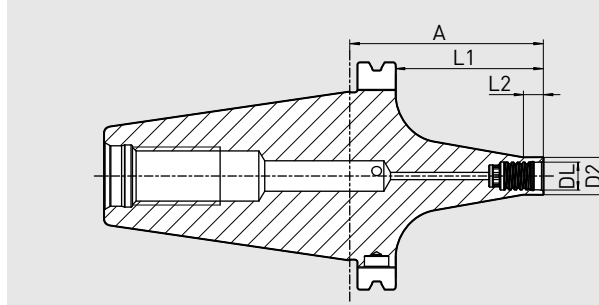

CERTIFICATE OF QUALITY

- ✓ Aufnahmekörper feingewuchtet
✓ Chuck body fine balanced
G2.5 25.000 1/min
oder/or U<1 gmm
- ✓ Alle Funktionsflächen feinbearbeitet
✓ All functional surfaces fine machined
- ✓ Kegeltoleranz AT3
✓ Taper tolerance AT3
- ✓ Kühlmittelzufuhr Form AD/AF
✓ Coolant supply form AD/AF

Duo-Lock Monoblockaufnahme für direkte Spannung.
Perfekt geeignet zum Fräsen und auch zum Schleifen der Duo-Lock Rohlinge.

Duo-Lock Monoblock holder for direct clamping.
Perfectly suitable for milling and also for grinding Duo-Lock blanks.

Mit Steilkegel SK50 Form AD/AF DIN 69871.

With steep taper SK50 Form AD/AF DIN 69871.

Form AD/AF bedeutet: zentrale Kühlmittelzufuhr und wiedererschließbare Kühlmittelkanäle am Bund.

Form AD/AF means: central coolant supply and coolant channels on the collar which can be sealed again.

- Alle Aufnahmen inkl. Innenkühlung
- Gehärtet 54-2 HRC
- Verstärkte Kontur
- Inkl. geschliffener Antastfläche und beschriftetem Korrekturwert

- All holders incl. inner coolant
- Hardened 54-2 HRC
- Reinforced geometry
- Incl. ground sensor surface and labeled correction value

SK50

Schnittstelle/Interface	DL10	DL12	DL16	DL20	DL25	DL32
∅ D2 [mm]	9,6	11,5	15,5	19,3	24	31
L1 [mm]	60,9	60,9	60,9	60,9	60,9	60,9
L2 [mm]	5	6	8	10	12,5	16
Maß/Length A [mm] kurz/short	80	80	80	80	80	80
Bestell-Nr./Order No. 50.490.DL...	10	12	16	20	25	32

Drehmoment der Duo-Lock Schnittstelle/Torque of Duo-Lock interface						
	DL10	DL12	DL16	DL20	DL25	DL32
Nm	20	30	60	80	100	130

Achtung: Für Langlebigkeit des Systems ist die Einhaltung des Drehmoments zwingend erforderlich
Attention: For long-life cycle of the system, compliance with the torque is required

DUO-LOCK® MONOBLOCKAUFNAHME DUO-LOCK® MONOBLOCK HOLDER JIS B 6339 · BT40

QUALITÄTSPASS
<ul style="list-style-type: none"> ✓ Aufnahmekörper feingewuchtet ✓ Chuck body fine balanced G2.5 25.000 1/min oder/or U<1 gmm
<ul style="list-style-type: none"> ✓ Alle Funktionsflächen feinbearbeitet ✓ All functional surfaces fine machined
<ul style="list-style-type: none"> ✓ Kegeltoleranz AT3 ✓ Taper tolerance AT3
<ul style="list-style-type: none"> ✓ Kühlmittelzufuhr Form JD/JF ✓ Coolant supply form JD/JF

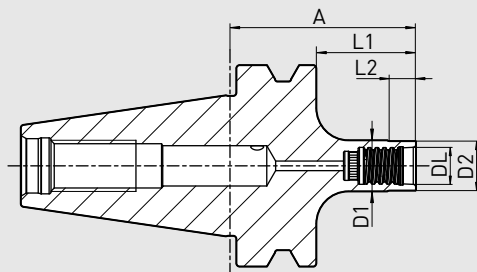

Duo-Lock Monoblockaufnahme für direkte Spannung.
Perfekt geeignet für das Fräsen mit kurzer Auskraglänge.

Duo-Lock Monoblock holder for direct clamping.
Perfectly suitable for milling with short overhang.

Mit Steilkegel BT40 Form JIS B 6339.

With steep taper BT40 Form JIS B 6339.

Form JD/JF bedeutet: zentrale Kühlmittelzufuhr und wiedererschließbare Kühlmittelkanäle am Bund.

Form JD/JF means: central coolant supply and coolant channels on the collar which can be sealed again.

- Alle Aufnahmen inkl. Innenkühlung
- Gehärtet 54-2 HRC

- All holders incl. inner coolant
- Hardened 54-2 HRC

BT40

Schnittstelle/Interface	DL10	DL12	DL16	DL20	DL25	DL32
∅ D1 [mm]	10	12	16	20	25	32
∅ D2 [mm]	9,6	11,5	15,5	19,3	24	31
L1 [mm]	22	22	31	31	33	41
L2 [mm]	5	6	8	10	12,5	16
Maß/Length A [mm]	49	49	58	58	60	68
Bestell-Nr./Order No. 40.690.DL...	10	12	16	20	25	32

Drehmoment der Duo-Lock Schnittstelle/Torque of Duo-Lock interface						
	DL10	DL12	DL16	DL20	DL25	DL32
Nm	20	30	60	80	100	130

Achtung: Für Langlebigkeit des Systems ist die Einhaltung des Drehmoments zwingend erforderlich
Attention: For long-life cycle of the system, compliance with the torque is required

DUO-LOCK® MONOBLOCKAUFNAHME DUO-LOCK® MONOBLOCK HOLDER DIN 69893-1 · HSK-A63

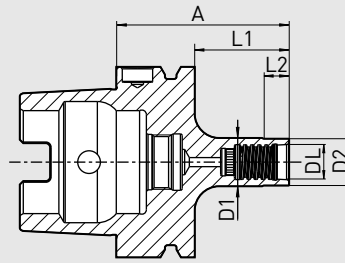

CERTIFICATE OF QUALITY

- ✓ Aufnahmekörper feingewuchtet
✓ Chuck body fine balanced
G2.5 25.000 1/min
oder/or U < 1 gmm
- ✓ Alle Funktionsflächen feinbearbeitet
✓ All functional surfaces fine machined
- ✓ Genauer als DIN
✓ More accurate than DIN

Duo-Lock Monoblockaufnahme für direkte Spannung.
Perfekt geeignet für das Fräsen mit kurzer Auskraglänge.

- Alle Aufnahmen inkl. Innenkühlung
- Gehärtet 54-2 HRC

Duo-Lock Monoblock holder for direct clamping.
Perfectly suitable for milling with short overhang.

- All holders incl. inner coolant
- Hardened 54-2 HRC

HSK-A63

Schnittstelle/Interface	DL10	DL12	DL16	DL20	DL25	DL32
∅ D1 [mm]	10	12	16	20	25	32
∅ D2 [mm]	9,6	11,5	15,5	19,3	24	31
L1 [mm]	22	26	31	31	35	46
L2 [mm]	5	6	8	10	12,5	16
Maß/Length A [mm] kurz/short	48	52	57	57	61	72
Bestell-Nr./Order No. A63.190.DL...	10	12	16	20	25	32

Drehmoment der Duo-Lock Schnittstelle/Torque of Duo-Lock interface						
	DL10	DL12	DL16	DL20	DL25	DL32
Nm	20	30	60	80	100	130

Achtung: Für Langlebigkeit des Systems ist die Einhaltung des Drehmoments zwingend erforderlich
Attention: For long-life cycle of the system, compliance with the torque is required

DUO-LOCK® MONOBLOCKAUFNAHME DUO-LOCK® MONOBLOCK HOLDER ISO 26623-1 · PSC 63

QUALITÄTSPASS

- ✓ Aufnahmekörper feingewuchtet
✓ Chuck body fine balanced
G2.5 25.000 1/min
oder/or U < 1 gmm
- ✓ Alle Funktionsflächen feinbearbeitet
✓ All functional surfaces fine machined
- ✓ Genauer als DIN
✓ More accurate than DIN

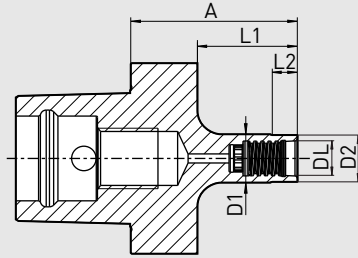

Duo-Lock Monoblockaufnahme für direkte Spannung.
Perfekt geeignet für das Fräsen mit kurzer Auskraglänge.

Duo-Lock Monoblock holder for direct clamping.
Perfectly suitable for milling with short overhang.

- Alle Aufnahmen inkl. Innenkühlung
- Gehärtet 54-2 HRC

- All holders incl. inner coolant
- Hardened 54-2 HRC

PSC 63

Schnittstelle/Interface	DL10	DL12	DL16	DL20	DL25	DL32
∅ D1 [mm]	10	12	16	20	25	32
∅ D2 [mm]	9,6	11,5	15,5	19,3	24	31
L1 [mm]	28	28	33	33	38	46
L2 [mm]	5	6	8	10	12,5	16
Maß/Length A [mm] kurz/short	50	50	55	55	60	68
Bestell-Nr./Order No. CC6.190.DL...	10	12	16	20	25	32

Drehmoment der Duo-Lock Schnittstelle/Torque of Duo-Lock interface

	DL10	DL12	DL16	DL20	DL25	DL32
Nm	20	30	60	80	100	130

Achtung: Für Langlebigkeit des Systems ist die Einhaltung des Drehmoments zwingend erforderlich
Attention: For long-life cycle of the system, compliance with the torque is required

DUO-LOCK® DIE AND MOLD AUFNAHME DUO-LOCK® DIE AND MOLD CHUCK DIN 69893-1 · HSK-A63

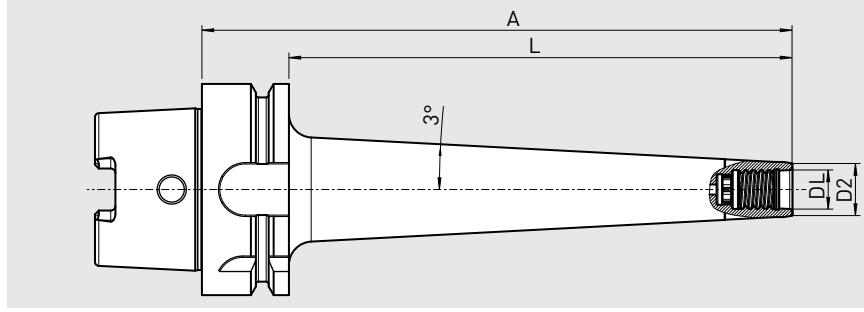

Duo-Lock Die and Mold Aufnahme für direkte Duo-Lock Spannung.

- Mit Durchgangsbohrung für Innenkühlung
- Stabile 3° Schräge für das perfekte Fräsen an Formschrägen
- Inklusive Hartmetallkern für schwingungsgedämpftes Fräsen bei langen Auskraglängen
- Reparatur gegen Aufpreis möglich (Fräserbruch in Schnittstelle)

Duo-Lock Die and Mold Chuck for direct Duo-Lock clamping.

- With inner coolant bore
- Stable 3° slant for perfect milling on inclined forms
- Including carbide core for vibration-damped milling with long overhang lengths
- Repair possible for an extra charge (end mill break in interface)

HSK-A63

Schnittstelle DL Interface DL	Bestell-Nr. Order No.	Außen Ø D2 [mm] Outer Ø D2 [mm]	Länge L [mm] Length L [mm]	Länge A [mm] Length A [mm]
DL10	A63.180.DL10.100	9,6	100	126
DL10	A63.180.DL10.125	9,6	125	151
DL10	A63.180.DL10.150	9,6	150	176
DL12	A63.180.DL12.100	11,5	100	126
DL12	A63.180.DL12.125	11,5	125	151
DL12	A63.180.DL12.150	11,5	150	176
DL16	A63.180.DL16.100	15,5	100	126
DL16	A63.180.DL16.125	15,5	125	151
DL16	A63.180.DL16.150	15,5	150	176
DL16	A63.180.DL16.175	15,5	175	201
DL16	A63.180.DL16.200	15,5	200	226
DL16	A63.180.DL16.250	15,5	250	276
DL20	A63.180.DL20.100	19,3	100	126
DL20	A63.180.DL20.125	19,3	125	151
DL20	A63.180.DL20.150	19,3	150	176
DL20	A63.180.DL20.175	19,3	175	201
DL20	A63.180.DL20.200	19,3	200	226
DL20	A63.180.DL20.250	19,3	250	276

Drehmoment der Duo-Lock Schnittstelle/Torque of Duo-Lock interface

	DL10	DL12	DL16	DL20
Nm	20	30	60	80

Achtung: Für Langlebigkeit des Systems ist die Einhaltung des Drehmoments zwingend erforderlich
Attention: For long-life cycle of the system, compliance with the torque is required

DUO-LOCK® DIE AND MOLD AUFNAHME DUO-LOCK® DIE AND MOLD CHUCK DIN 69893-1 · HSK-A100

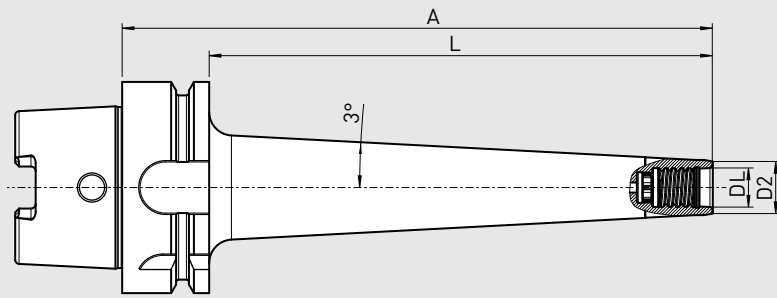

Duo-Lock Die and Mold Aufnahme für direkte Duo-Lock Spannung.

- Mit Durchgangsbohrung für Innenkühlung
- Stabile 3° Schräge für das perfekte Fräsen an Formschrägen
- Inklusive Hartmetallkern für schwingungsgedämpftes Fräsen bei langen Auskräglängen
- Reparatur gegen Aufpreis möglich (Fräserbruch in Schnittstelle)

Duo-Lock Die and Mold Chuck for direct Duo-Lock clamping.

- With inner coolant bore
- Stable 3 ° slant for perfect milling on inclined forms
- Including carbide core for vibration-damped milling with long overhang lengths
- Repair possible for an extra charge (end mill break in interface)

HSK-A100

Schnittstelle DL Interface DL	Bestell-Nr. Order No.	Außen Ø D2 [mm] Outer Ø D2 [mm]	Länge L [mm] Length L [mm]	Länge A [mm] Length A [mm]
DL10	A10.180.DL10.100	9,6	100	129
DL10	A10.180.DL10.150	9,6	150	179
DL12	A10.180.DL12.100	11,5	100	129
DL12	A10.180.DL12.150	11,5	150	179
DL12	A10.180.DL12.200	11,5	200	229
DL12	A10.180.DL12.250	11,5	250	279
DL16	A10.180.DL16.100	15,5	100	129
DL16	A10.180.DL16.150	15,5	150	179
DL16	A10.180.DL16.200	15,5	200	229
DL16	A10.180.DL16.250	15,5	250	279
DL20	A10.180.DL20.100	19,3	100	129
DL20	A10.180.DL20.150	19,3	150	179
DL20	A10.180.DL20.200	19,3	200	229
DL20	A10.180.DL20.250	19,3	250	279

Drehmoment der Duo-Lock Schnittstelle/Torque of Duo-Lock interface				
	DL10	DL12	DL16	DL20
Nm	20	30	60	80

Achtung: Für Langlebigkeit des Systems ist die Einhaltung des Drehmoments zwingend erforderlich
Attention: For long-life cycle of the system, compliance with the torque is required

DUO-LOCK® LÄNGENVOREINSTELL-WERKZEUG DUO-LOCK® LENGTH PRESETTING TOOL

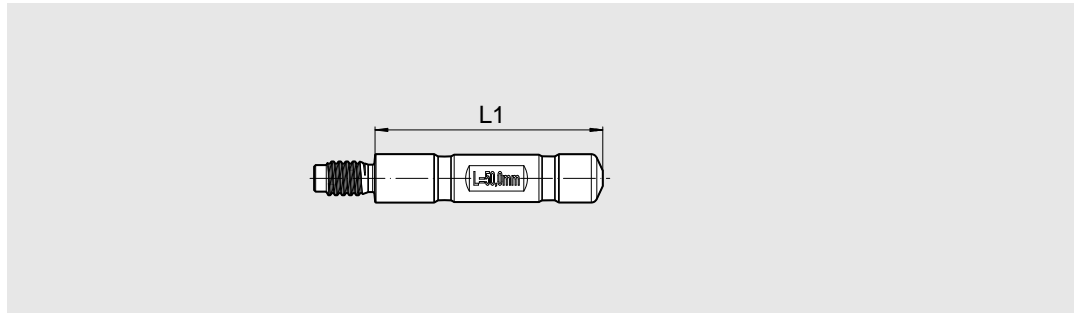

- Einschrumpfhilfe
- Längenvoreinstellung

- Shrinking assistance
- Length presetting

Duo-Lock Längenvoreinstell-Werkzeug/Duo-Lock length presetting tool	
Bestell-Nr./Order No.	Größe/Size
75.000.DL10	DL10
75.000.DL12	DL12
75.000.DL16	DL16
75.000.DL20	DL20
75.000.DL25	DL25
75.000.DL32	DL32

DUO-LOCK® TORQUE MASTER DUO-LOCK® TORQUE MASTER

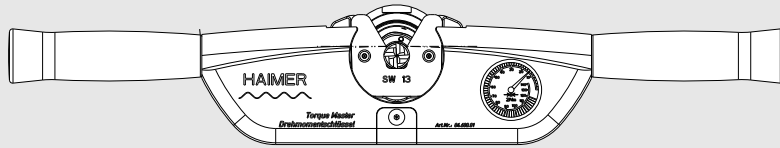

Zweiarmiger Drehmomentschlüssel für Duo-Lock

- Für höchste Rundlaufgenauigkeit, kein einseitiges Spannen
- Optimale Kraftübertragung durch gleichmäßige Kräfteinleitung
- Drehmomentschlüssel für höchste Spann- und Wiederholgenauigkeit mit Messuhr
- Maximales Drehmoment für höchste Haltekräfte
- Keine Überlastung kleiner Spanndurchmesser
- Auswechselbare Einsätze, auch für Standard ER-Muttern geeignet
- Verlängerte Griffstücke für DL16 – DL32

Two-armed torque wrench for Duo-Lock

- For highest runout accuracy, avoids one-sided clamping
- Optimal power transmission by constant force application
- Torque wrench for highest clamping accuracy and repeatability with dial gauge
- Maximum torque for highest clamping force
- No overloading of smaller clamping diameters
- Changeable inserts, useable also for standard ER-Nuts
- Extended grips for DL16 – DL32

Drehmomentschlüssel für Duo-Lock/Torque wrench for Duo-Lock

Duo-Lock Drehmomentschlüsselset mit Koffer, 6 Gabelstücke und Griffset lang Torque Master Set Duo-Lock with case, 6 inserts and grip sets, long	84.600.20.AK
Duo-Lock Drehmomentschlüsselset mit Griffset, lang (ohne Gabelstücke) Torque Master Duo-Lock incl. grip set long (without inserts)	84.600.20
Duo-Lock Griffset lang für Drehmomentschlüssel Grip set long for Torque Master Duo-Lock	84.600.10.1

Drehmoment der Duo-Lock Schnittstelle/Torque of Duo-Lock interface

	DL10	DL12	DL16	DL20	DL25	DL32
Nm	20	30	60	80	100	130

Achtung: Für Langlebigkeit des Systems ist die Einhaltung des Drehmoments zwingend erforderlich
Attention: For long-life cycle of the system, compliance with the torque is required

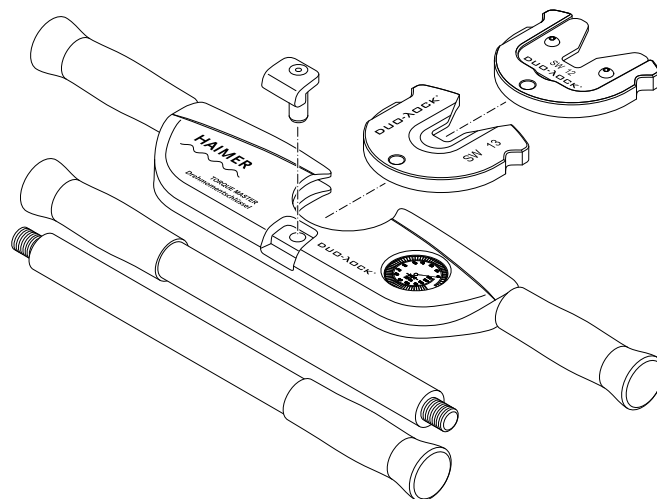

GABELSTÜCKE (EINSÄTZE) FÜR DUO-LOCK® TORQUE MASTER INSERTS FOR DUO-LOCK® TORQUE MASTER

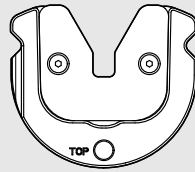

DL10 – DL12: mit Verschleißeinsetz
DL10 – DL12: with Wear insert

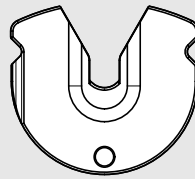

DL16 – DL32: gefertigt aus einem Teil
DL16 – DL32: Made of a single piece

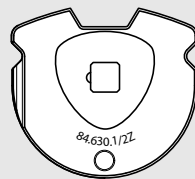

Zur Aufnahme aller gängigen Vierkantsteckschlüssel mit 1/2"
To insert all common square socket wrenches with 1/2"

- Austauschbare Gabelstücke zum Einsetzen in Duo-Lock Drehmomentschlüssel
- Passend für Duo-Lock Einschraubfräser

- Exchangeable inserts for Duo-Lock Torque Master
- Suitable for Duo-Lock milling heads

Gabelstücke/Inserts		
Bestell-Nr./Order No.	Größe/Size	SW/AF [mm]
84.640.10	DL10	8
84.640.12	DL12	9,5
84.640.16	DL16	13
84.640.20	DL20	16
84.640.25	DL25	21
84.640.32	DL32	28
84.630.1/2Z	Zur Aufnahme aller gängigen Vierkantsteckschlüssel mit 1/2" To insert all common square socket wrenches with 1/2"	

Zubehör/Accessories

Verschleißeinsetz/Wear insert

Größe/Size
Bestell-Nr./Order No. 84.640...



DL10
.10.1

DL12
.12.1

ROLLENSPANNSCHLÜSSEL ZUM SPANNEN VON DUO-LOCK® ROHLINGEN ROLLER BEARING WRENCH FOR CLAMPING DUO-LOCK® BLANKS

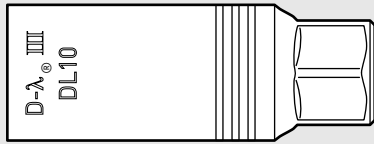

- Passend für Duo-Lock Rohlinge von DL10 – DL20
- Für Vierkanratsche mit 1/2"

- Useable for Duo-Lock blanks from DL10 – DL20
- For square socket ratchet with 1/2"

Rollenspannschlüssel/Roller Bearing Wrench	
Bestell-Nr./Order No.	Größe/Size
84.645.DL10	DL10
84.645.DL12	DL12
84.645.DL16	DL16
84.645.DL20	DL20

DUO-LOCK® HANDSCHLÜSSEL DUO-LOCK® HAND WRENCH

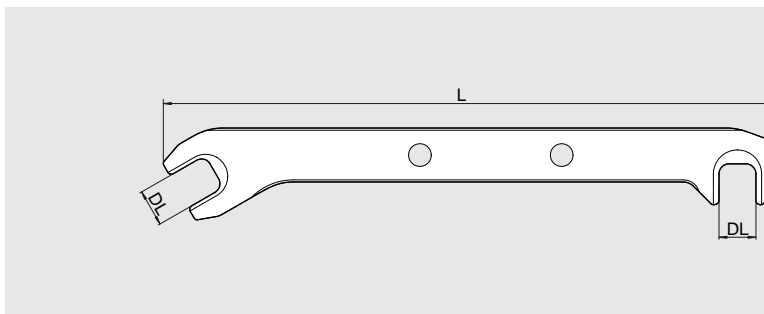

- Passend für Duo-Lock Fräsköpfe von DL10 – DL20
- Zum direkten Duo-Lock Werkzeugwechsel in der Drehmaschine
- Useable for Duo-Lock tool heads from DL10 – DL20
- For replacing Duo-Lock tool heads directly in the lathe

Duo-Lock Handschlüssel/Duo-Lock Hand wrench		
Bestell-Nr./Order No.	Größe/Size	Gesamtlänge L/Overall length L [mm]
84.647.DL10	DL10	196
84.647.DL12	DL12	199
84.647.DL16	DL16	217
84.647.DL20	DL20	236

DUO-LOCK® SPANNZANGEN SPANNVORRICHTUNG DUO-LOCK® COLLETS CLAMPING DEVICE

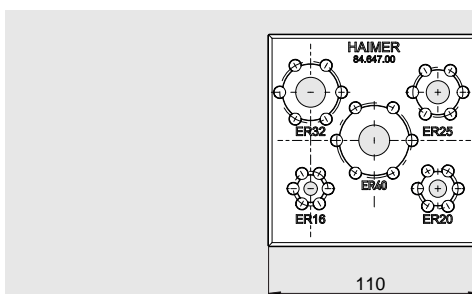

- Passend für Duo-Lock Spannzangen ER16, ER20, ER25, ER32, ER40
- Spannflächen für die Spannung im Schraubstock
- Useable for Duo-Lock collets from ER16, ER20, ER25, ER32, ER40
- Clamping surfaces for the tension in the vice

Duo-Lock Spannzangen Spannvorrichtung/Duo-Lock collets clamping device	
Bestell-Nr./Order No.	Größe/Size
84.647.00	ER16, ER20, ER25, ER32, ER40

7001 DREHMOMENTSCHLÜSSEL DL10 – DL20

7001 TORQUE WRENCH DL10 – DL20

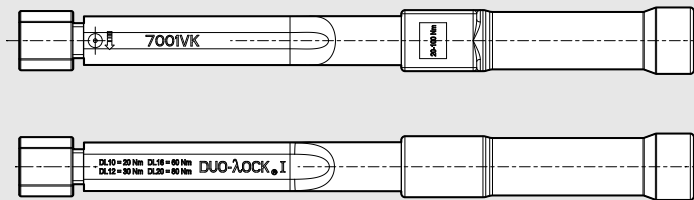

- 7001 Drehmomentschlüssel mit Umschaltknarre
- Zum direkten Duo-Lock Werkzeugwechsel in der Drehmaschine
- Drehmoment: 20 – 100 Nm
- Passend für Duo-Lock Einschraubfräser von DL10 – DL20
- Anschluss: 9 x 12 mm
- Anwendung: Für Rechts- und Linksanzug

- 7001 torque wrench with changeover ratchet
- For changing Duo-Lock tool heads directly in the lathe
- Torque: 20 – 100 Nm
- Useable for Duo-Lock milling heads from DL10 – DL20
- Connecting size 9 x 12 mm
- Changeable to clockwise and counter clockwise

Drehmomentschlüssel für Duo-Lock/Torque wrench for Duo-Lock

Bestell-Nr./Order No.

7001 Drehmomentschlüssel 9 x 12 mm

7001 Torque wrench 9 x 12 mm

82.587.00

Drehmoment der Duo-Lock Schnittstelle/Torque of Duo-Lock interface

	DL10	DL12	DL16	DL20
Nm	20	30	60	80

DUO-LOCK® AUFsätze FÜR 7001 DREHMOMENTSCHLÜSSEL

DUO-LOCK® INSERTS FOR 7001 TORQUE WRENCH

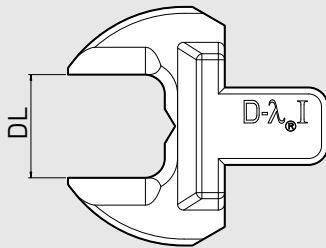

- Zum direkten Duo-Lock Werkzeugwechsel in der Drehmaschine
- Auswechselbare Aufsätze zum Einsetzen in den 7001 Drehmomentschlüssel
- Passend für Duo-Lock Einschraubfräser von DL10 – DL20
- Anschluss: 9 x 12 mm

- For changing Duo-Lock tool heads directly in the lathe
- Changeable inserts for 7001 torque wrench
- Useable for Duo-Lock milling heads from DL10 – DL20
- Connecting size 9 x 12 mm

Aufsatz/Insert

Bestell-Nr./Order No.	Größe/Size
82.587.DL10	DL10
82.587.DL12	DL12
82.587.DL16	DL16
82.587.DL20	DL20

7003 DREHMOMENTSCHLÜSSEL DL16 – DL32 7003 TORQUE WRENCH DL16 – DL32

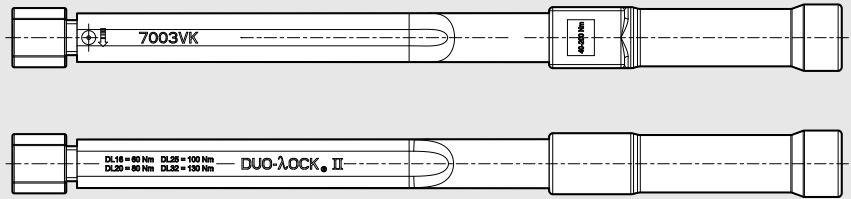

- 7003 Drehmomentschlüssel mit Umschaltknarre
 - Zum direkten Duo-Lock Werkzeugwechsel in der Drehmaschine
 - Drehmoment: 40 – 200 Nm
 - Passend für Duo-Lock Einschraubfräser von DL16 – DL32
 - Anschluss: 14 x 18 mm
 - Anwendung: Für Rechts- und Linksanzug
- 7003 torque wrench with changeover ratchet
 - For changing Duo-Lock tool heads directly in the lathe
 - Torque: 40 – 200 Nm
 - Useable for Duo-Lock milling heads from DL16 – DL32
 - Connecting size 14 x 18 mm
 - Changeable to clockwise and counter clockwise

Drehmomentschlüssel für Duo-Lock/Torque wrench for Duo-Lock	Bestell-Nr./Order No.
7003 Drehmomentschlüssel 14 x 18 mm	
7003 Torque wrench 14 x 18 mm	82.588.00

Drehmoment der Duo-Lock Schnittstelle/Torque of Duo-Lock interface				
	DL16	DL20	DL25	DL32
Nm	60	80	100	130

DUO-LOCK® AUFSÄTZE FÜR 7003 DREHMOMENTSCHLÜSSEL DUO-LOCK® INSERTS FOR 7003 TORQUE WRENCH

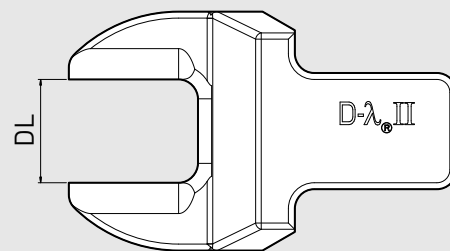

- Zum direkten Duo-Lock Werkzeugwechsel in der Drehmaschine
 - Auswechselbare Aufsätze zum Einsetzen in den 7003 Drehmomentschlüssel
 - Passend für Duo-Lock Einschraubfräser von DL16 – DL32
 - Anschluss: 14 x 18 mm
- For changing Duo-Lock tool heads directly in the lathe
 - Changeable inserts for 7003 torque wrench
 - Useable for Duo-Lock milling heads from DL16 – DL32
 - Connecting size 14 x 18 mm

Aufsatz/Insert	
Bestell-Nr./Order No.	Größe/Size
82.588.DL16	DL16
82.588.DL20	DL20
82.588.DL25	DL25
82.588.DL32	DL32



HAIMER DUO-LOCK®

Für schnellste Werkzeugwechsel und höchste
Belastbarkeit beim Drehen und Fräsen

For fastest tool change and highest performance
in turning and milling applications

FORMULAR SONDERANFRAGE VHM-FRÄSER

Sonderanfragenummer

Datum

Firma	Kunden-Nr.
Straße	Ansprechpartner
PLZ/Ort	Telefon
Land	E-Mail

Anwendungstechniker

Außendienst

Innendienst

Artikelgruppen

- | | | |
|--|--|--|
| <input type="checkbox"/> E1012 – Z2 | <input type="checkbox"/> F1005 – Z5 Power Series | <input type="checkbox"/> F4002 – Z2 Alu Series |
| <input type="checkbox"/> E1014 – Z4 | <input type="checkbox"/> F1104 – Z4 Power Series | <input type="checkbox"/> F4003 – Z3 Alu Series |
| <input type="checkbox"/> E1016 – Z6 | <input type="checkbox"/> F1105 – Z5 Power Series | <input type="checkbox"/> V1002 – Z2 Power Series |
| <input type="checkbox"/> F1003 – Z3 Power Series | <input type="checkbox"/> F1304 – Z4 Power Series | <input type="checkbox"/> V4002 – Z2 Alu Series |
| <input type="checkbox"/> F1004 – Z4 Power Series | <input type="checkbox"/> F2004 – Z4 | |

Basis-Artikelnummer

Zentrum schneidend

Ja Nein

Spanbrecher

Ja Nein

Schaft

Abmessungen

Alle Durchmesser- und Längenangaben in mm

- HA
Glattschaft
- HB
Weldonschaft
- Safe-Lock
Schaft

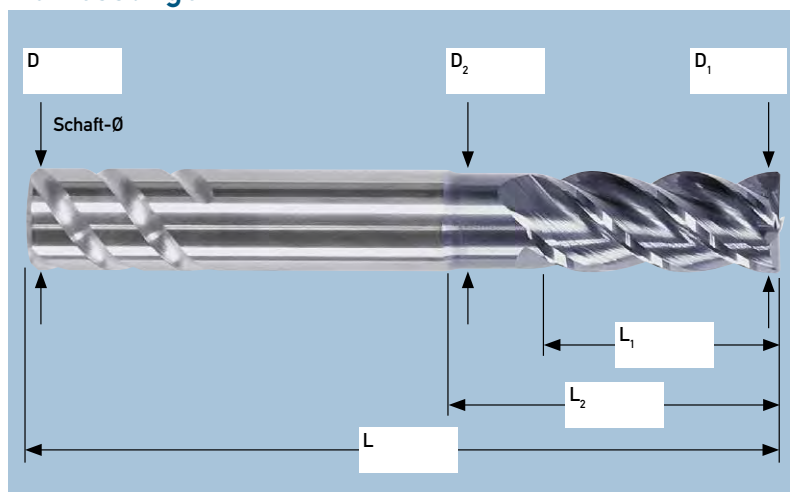

Eckengeometrie

Scharfkantig (S)



Radius
R



Fase
C



∅

Beschichtung

Ja Nein

Kühlung

- Trocken
- MMS
- Luft
- Schmierstoff:

Einsatzbereich

Material (Werkstoffnummer)	Schnitttiefe a_p in mm	Schnittgeschwindigkeit V_c in m/min
Härte/Zugfestigkeit	Schnittbreite a_e in mm	Vorschub F_z in mm

Kalkulation

Jahresumsatz Kunde	Anzahl	Preis	Anzahl	Preis
Jahresumsatz Fräser Kunde				

Mitbewerber

Kunde arbeitet aktuell mit

Kosten des Werkzeugs

Kommentar / Einsatzbeschreibung

FORM SPECIAL REQUEST SOLID CARBIDE END MILL

Special Request Number

Date

Company	Customer-No.
Street	Contact Person
City/Zip Code	Phone
State/Country	Email

Applications Engineer
External Sales Representative
Internal Sales Representative

Product Groups

- | | | |
|--|--|--|
| <input type="checkbox"/> E1012 – Z2 | <input type="checkbox"/> F1005 – Z5 Power Series | <input type="checkbox"/> F4002 – Z2 Alu Series |
| <input type="checkbox"/> E1014 – Z4 | <input type="checkbox"/> F1104 – Z4 Power Series | <input type="checkbox"/> F4003 – Z3 Alu Series |
| <input type="checkbox"/> E1016 – Z6 | <input type="checkbox"/> F1105 – Z5 Power Series | <input type="checkbox"/> V1002 – Z2 Power Series |
| <input type="checkbox"/> F1003 – Z3 Power Series | <input type="checkbox"/> F1304 – Z4 Power Series | <input type="checkbox"/> V4002 – Z2 Alu Series |
| <input type="checkbox"/> F1004 – Z4 Power Series | <input type="checkbox"/> F2004 – Z4 | |

Standard Article No.

Center Cutting



- Yes No

Chip breaker

- Yes No

Shank



All diameters and lengths in mm

- HA Straight Shank 
- HB Weldon Shank 
- Safe-Lock Shank 

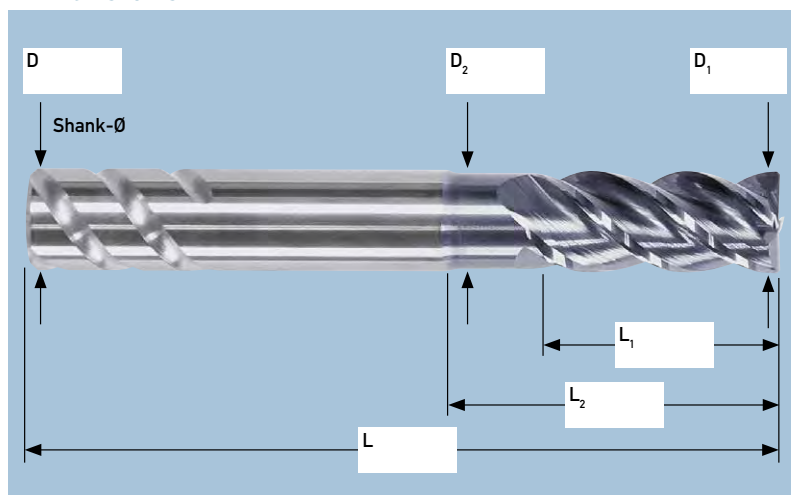
Dimensions



Face Geometry

- Sharp Corner (S) 
- Radius R 
- Chamfer C 

Coating

- Yes No

Areas of Application

Material (Material Number)	Cutting Depth a_p in mm	Cutting Speed V_c in m/min
Hardness/Tensile Strength	Cutting Width a_e in mm 	Feed per Tooth F_z in mm

Cooling

- Dry
- MQL
- Air
- Lubricant:

Calculation

Customer Annual Sales	Quantity	Price	Quantity	Price
<input type="text"/>	<input type="text"/>	<input type="text"/>	<input type="text"/>	<input type="text"/>
Customer Mills Annual Sales	<input type="text"/>	<input type="text"/>	<input type="text"/>	<input type="text"/>

Competitor

Customer is currently working with

Cost of the tool

Comments / Description of Application

FORMULAR SONDERANFRAGE DUO-LOCK®

Sonderanfragenummer

Datum

Firma	Kunden-Nr.
Straße	Ansprechpartner
PLZ/Ort	Telefon
Land	E-Mail

Anwendungstechniker

Außendienst

Innendienst

Artikelgruppen

- | | | |
|---|---|--|
| <input type="checkbox"/> E1012 – Z2 Power Series | <input type="checkbox"/> F2003 – Z3 | <input type="checkbox"/> H2004 – HF Series |
| <input type="checkbox"/> E1014 – Z4 Power Series | <input type="checkbox"/> F2004 – Z4 | <input type="checkbox"/> H2006 – HF Series |
| <input type="checkbox"/> E1016/18 – Z6/8 Power Series | <input type="checkbox"/> F2006/08/00 – Z6/8/10 Series | <input type="checkbox"/> V2002 – Z2 |
| <input type="checkbox"/> F1004 – Z4 Power Series | <input type="checkbox"/> F2304 – Z4 | <input type="checkbox"/> V2004 – Z4 |
| <input type="checkbox"/> F1105 – Z5 Power Series | <input type="checkbox"/> F4002 – Z2 Alu Series | <input type="checkbox"/> V4002 – Z2 Alu Series |
| | <input type="checkbox"/> F4003 – Z3 Alu Series | |

Basis-Artikelnummer

Zentrum schneidend

Ja Nein

Spanbrecher

Ja Nein

Abmessungen

Alle Durchmesser- und Längenangaben in mm

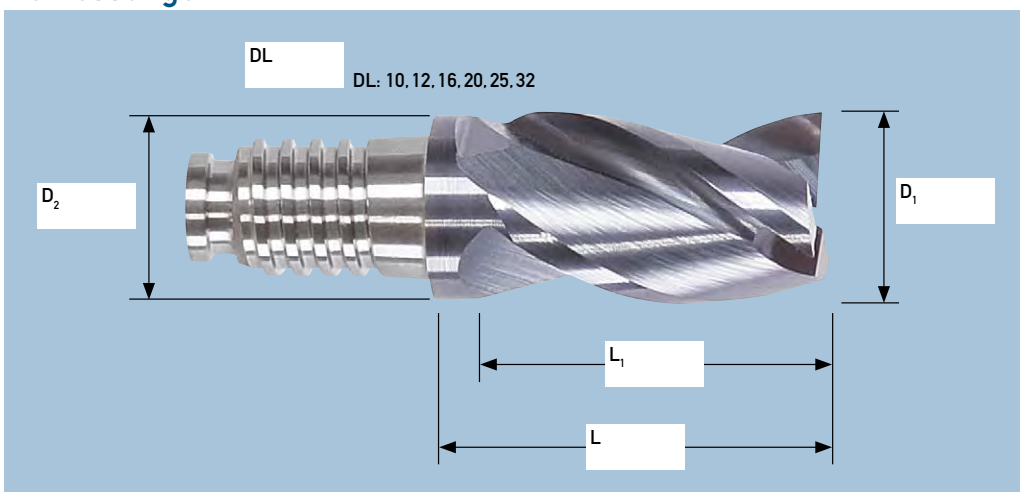

Eckengeometrie

Scharfkantig (S)



Radius

R



Fase

C



∅

Beschichtung

Ja Nein

Kühlung

Trocken

MMS

Luft

Schmierstoff:

Einsatzbereich

Material (Werkstoffnummer)	Schnitttiefe a_p in mm	Schnittgeschwindigkeit V_c in m/min
Härte/Zugfestigkeit	Schnittbreite a_e in mm	Vorschub F_z in mm

Kalkulation

Jahresumsatz Kunde	Anzahl	Preis	Anzahl	Preis
Jahresumsatz Fräser Kunde				

Mitbewerber

Kunde arbeitet aktuell mit

Kosten des Werkzeugs

Kommentar / Einsatzbeschreibung

FORM SPECIAL REQUEST DUO-LOCK®

Special Request Number

Date

Company	Customer-No.
Street	Contact Person
City/Zip Code	Phone
State/Country	Email

Applications Engineer
External Sales Representative
Internal Sales Representative

Product Groups

- | | | |
|---|--|--|
| <input type="checkbox"/> E1012 – Z2 Power Series | <input type="checkbox"/> F2003 – Z3 | <input type="checkbox"/> H2004 – HF Series |
| <input type="checkbox"/> E1014 – Z4 Power Series | <input type="checkbox"/> F2004 – Z4 | <input type="checkbox"/> H2006 – HF Series |
| <input type="checkbox"/> E1016/18 – Z6/8 Power Series | <input type="checkbox"/> F2006/08/00 – Z6/8/10 | <input type="checkbox"/> V2002 – Z2 |
| <input type="checkbox"/> F1004 – Z4 Power Series | <input type="checkbox"/> F2304 – Z4 | <input type="checkbox"/> V2004 – Z4 |
| <input type="checkbox"/> F1105 – Z5 Power Series | <input type="checkbox"/> F4002 – Z2 Alu Series | <input type="checkbox"/> V4002 – Z2 Alu Series |
| | <input type="checkbox"/> F4003 – Z3 Alu Series | |

Standard Article No.

Center Cutting

- Yes No

Chip breaker

- Yes No

Dimensions

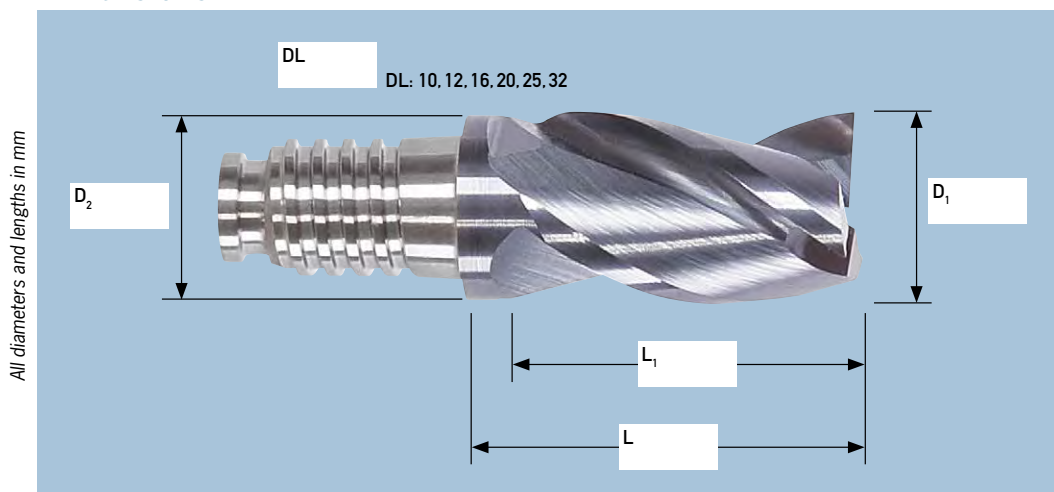

Face Geometry

- Sharp Corner (S)



- Radius

R

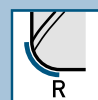

- Chamfer

C



Coating

- Yes No

Areas of Application

Material (Material Number)	Cutting Depth a_p in mm	Cutting Speed V_c in m/min
Hardness/Tensile Strength	Cutting Width a_e in mm	Feed per Tooth F_z in mm

Cooling

- Dry
 MQL
 Air
 Lubricant:

Calculation

Customer Annual Sales	Quantity	Price	Quantity	Price
Customer Mills Annual Sales				

Competitor

Customer is currently working with

Cost of the tool

Comments / Description of Application

FORMULAR SONDERANFRAGE HALSFREISETZUNG-FRÄSER

Sonderanfragenummer

Datum

Firma	Kunden-Nr.
Straße	Ansprechpartner
PLZ/Ort	Telefon
Land	E-Mail

Anwendungstechniker

Außendienst

Innendienst

Basis-Artikelnummer

Abmessungen

Alle Durchmesser- und Längenangaben in mm

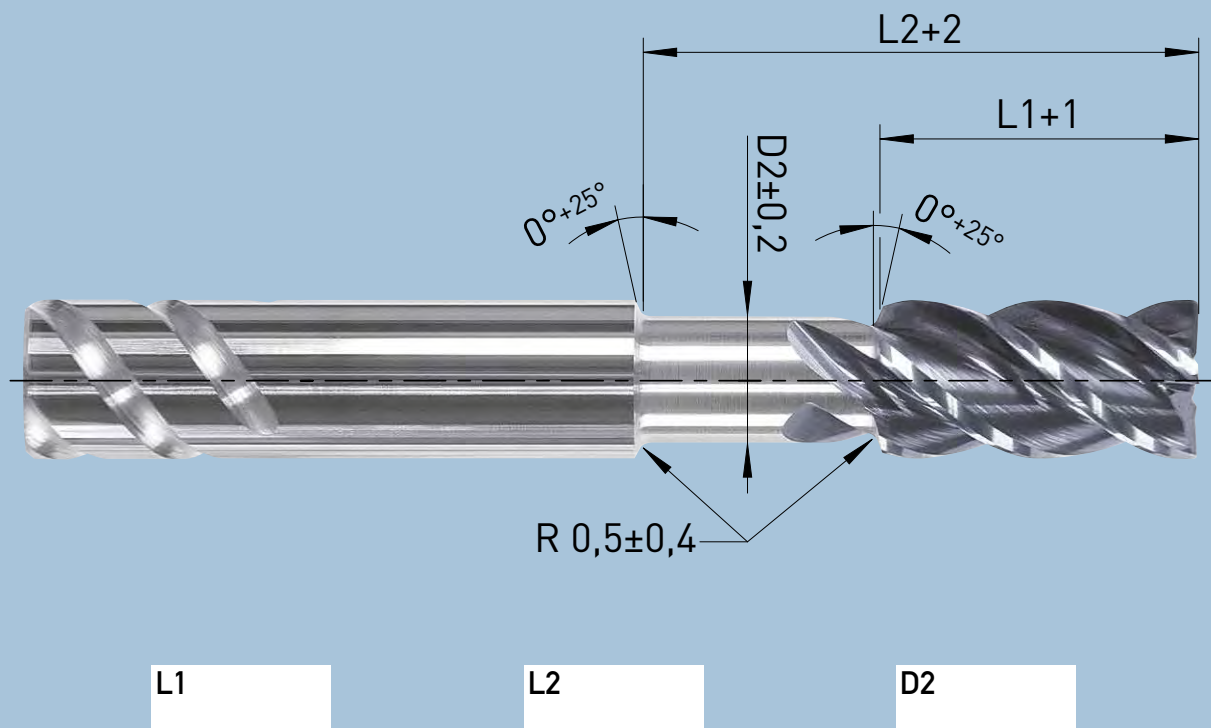

Kalkulation

Jahresumsatz Kunde	Anzahl	Preis	Anzahl	Preis
<input type="text"/>	<input type="text"/>	<input type="text"/>	<input type="text"/>	<input type="text"/>
Jahresumsatz Fräser Kunde				
<input type="text"/>	<input type="text"/>	<input type="text"/>	<input type="text"/>	<input type="text"/>

Hinweis

Eine Halsfreisetzung nach Kundenwunsch kann die Leistung des Fräasers beeinträchtigen.

Kommentar / Einsatzbeschreibung

FORM SPECIAL REQUEST NECK RELEASE END MILL

Special Request Number

Date

Company	Customer-No.
Street	Contact Person
City/Zip Code	Phone
State/Country	Email

Applications Engineer
External Sales Representative
Internal Sales Representative

Standard Article No.

Dimensions

All diameters and lengths in mm

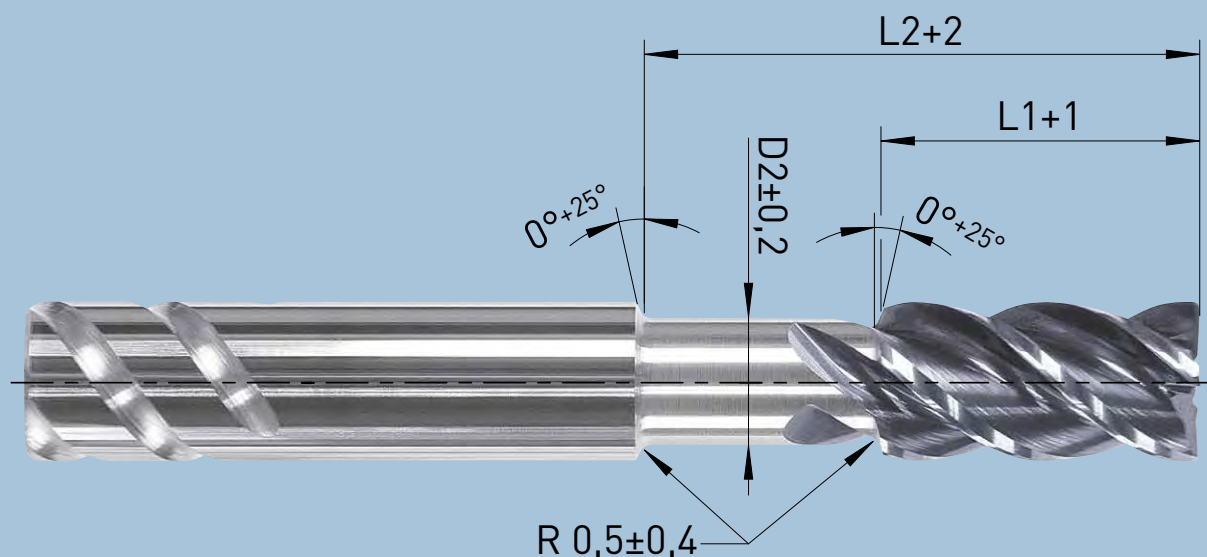

L1

L2

D2

Calculation

Customer Annual Sales	Quantity	Price	Quantity	Price
<input type="text"/>	<input type="text"/>	<input type="text"/>	<input type="text"/>	<input type="text"/>
Customer Mills Annual Sales	<input type="text"/>	<input type="text"/>	<input type="text"/>	<input type="text"/>

Note

A neck release according to the customer's wishes can affect the performance of the end mill.

Comments / Description of Application

FORMULAR SONDERANFRAGE DUO-LOCK® ROHLING

Sonderanfragenummer

Datum

Firma	Kunden-Nr.
Straße	Ansprechpartner
PLZ/Ort	Telefon
Land	E-Mail

Anwendungstechniker

Außendienst

Innendienst

Schlüsselweite

- Ja
 Nein

Übermaß

- Ja
 Nein

Innenkühlung

- Nein
 Zentrale Kühlung
 Y-Kühlung

Basis-Artikelnummer

Abmessungen

Alle Durchmesser- und Längenangaben in mm

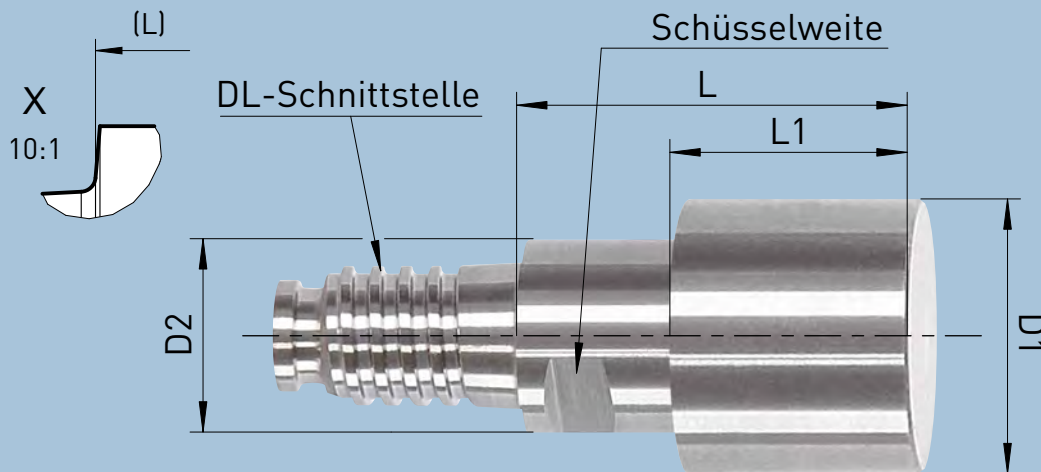

DL

L

D1

L1

D2

DIK

DIK1

DIK2

L2

L3

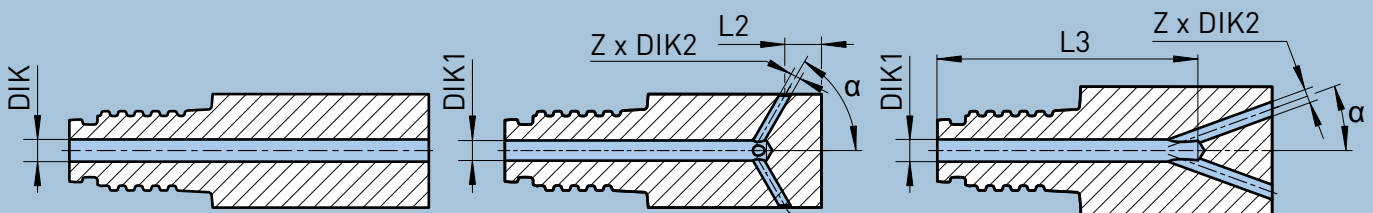

Kalkulation

Jahresumsatz Kunde	Anzahl	Preis	Anzahl	Preis
Jahresumsatz Fräser Kunde				

Y-Kühlung Winkel

α

Y-Kühlung Anzahl

Z

Kommentar

FORM SPECIAL REQUEST DUO-LOCK® BLANK

Special Request Number

Date

Company	Customer-No.
Street	Contact Person
City/Zip Code	Phone
State/Country	Email

Applications Engineer

External Sales Representative

Internal Sales Representative

Across flats

- Yes
- No

Oversize

- Yes
- No

Inner Cooling

- No
- Central Cooling
- Y Cooling

Standard Article No.

Dimensions

All diameters and lengths in mm

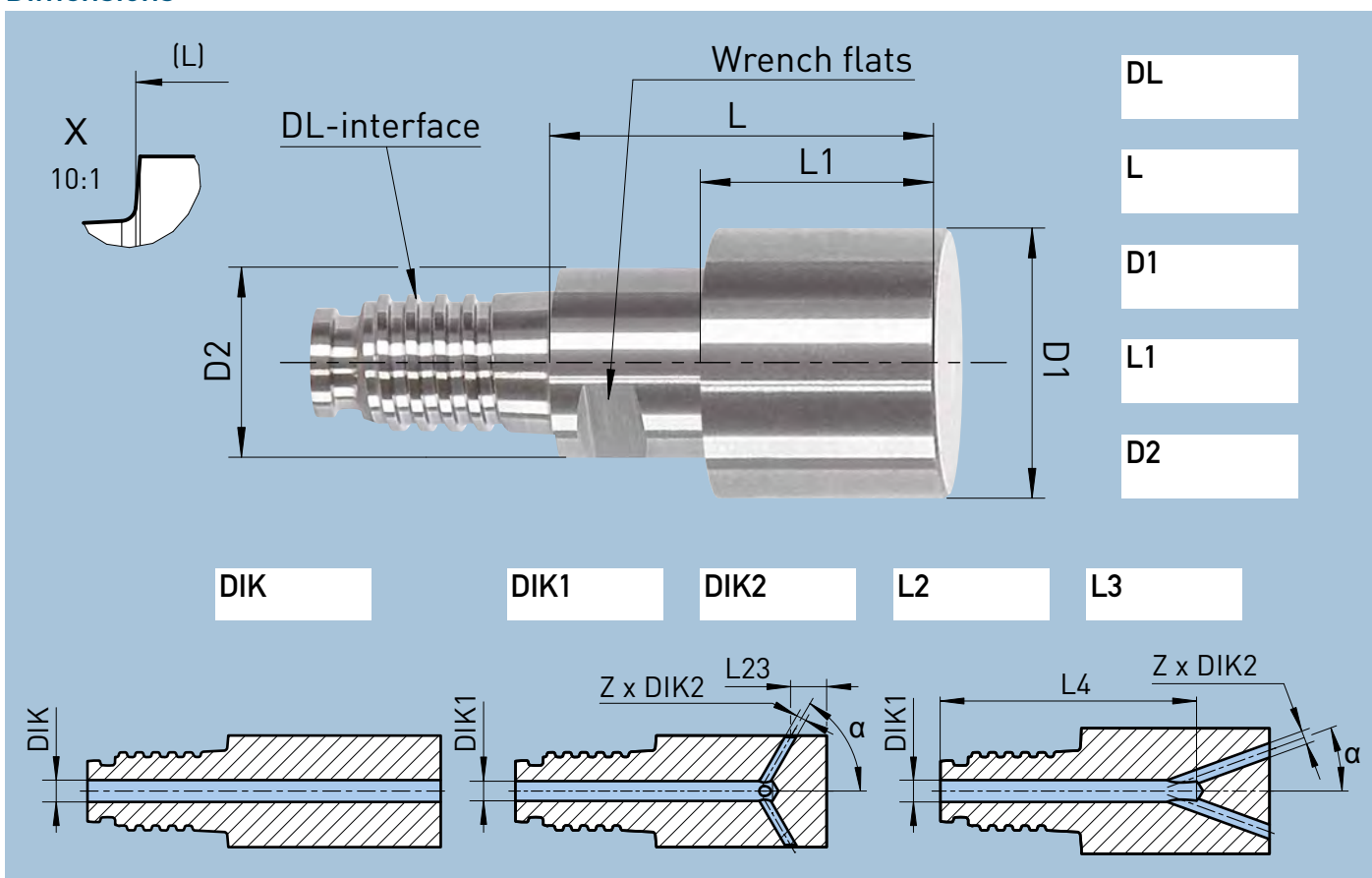

DL

L

D1

L1

D2

DIK

DIK1

DIK2

L2

L3

Calculation

Customer Annual Sales	Quantity	Price	Quantity	Price
Customer Mills Annual Sales				

Y-Cooling Angle

α

Y-Cooling Number

Z

Comments

FORMULAR SONDERANFRAGE FREISETZUNG DUO-LOCK® VERLÄNGERUNG

Sonderanfragenummer

Datum

Firma	Kunden-Nr.
Straße	Ansprechpartner
PLZ/Ort	Telefon
Land	E-Mail

Anwendungstechniker

Außendienst

Innendienst

Basis-Artikelnummer

Abmessungen

Alle Durchmesser- und Längenangaben in mm

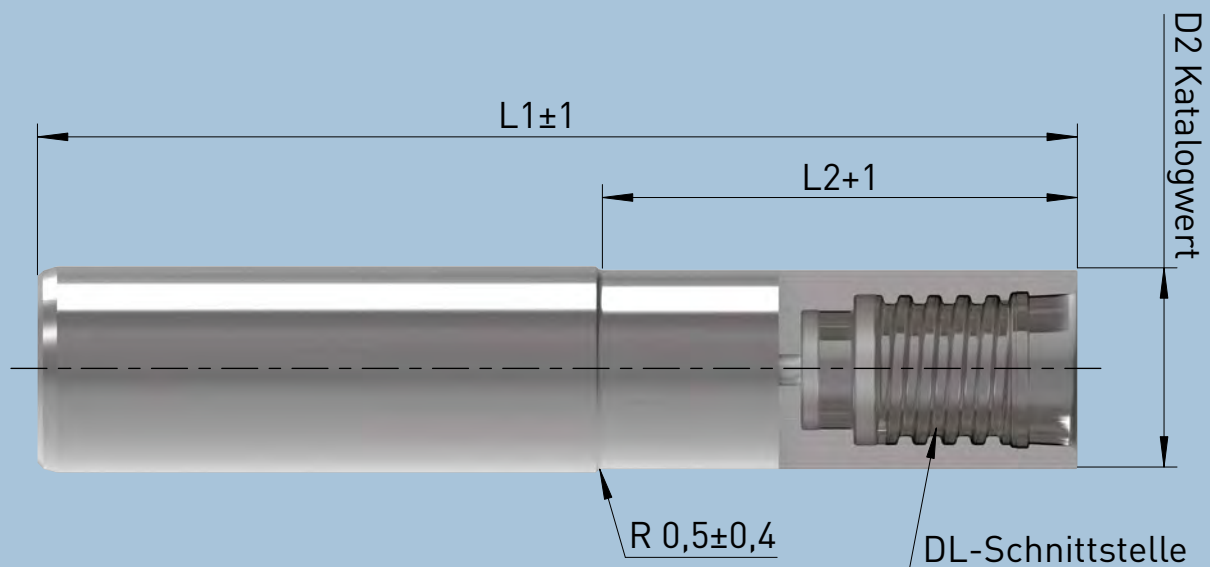

L1

L2

DL

Kalkulation

Jahresumsatz Kunde	Anzahl	Preis	Anzahl	Preis
<input type="text"/>	<input type="text"/>	<input type="text"/>	<input type="text"/>	<input type="text"/>
Jahresumsatz Fräser Kunde	<input type="text"/>	<input type="text"/>	<input type="text"/>	<input type="text"/>
<input type="text"/>	<input type="text"/>	<input type="text"/>	<input type="text"/>	<input type="text"/>

Hinweis

Eine Freisetzung nach Kundenwunsch kann die Stabilität der DUO-LOCK®-Verlängerung beeinträchtigen.

Kommentar / Einsatzbeschreibung

FORM SPECIAL REQUEST RELIEF DUO-LOCK® EXTENSION

Special Request Number

Date

Company	Customer-No.
Street	Contact Person
City/Zip Code	Phone
State/Country	Email

Applications Engineer
External Sales Representative
Internal Sales Representative

Standard Article No.

Dimensions

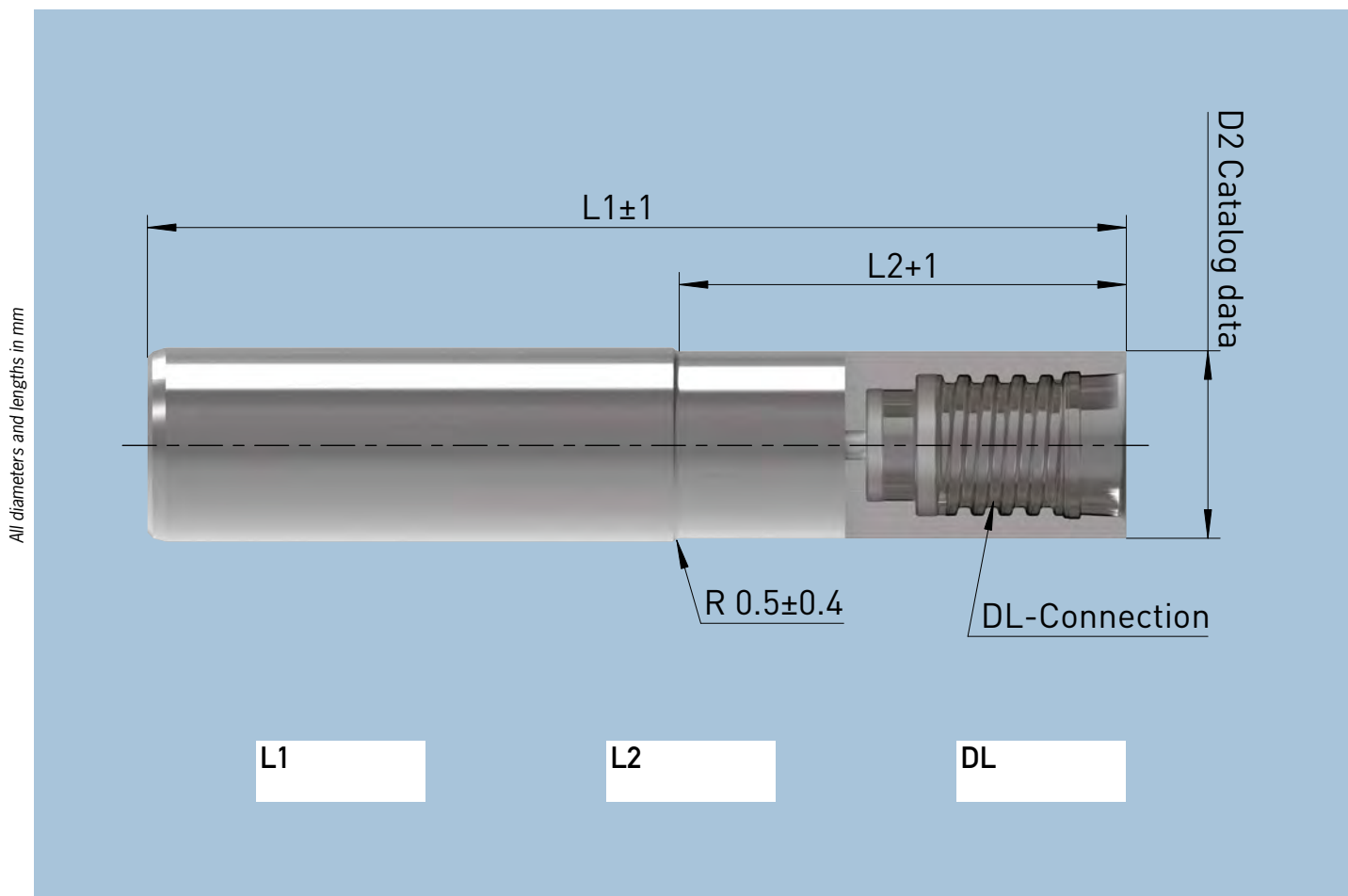

Calculation

Customer Annual Sales	Quantity	Price	Quantity	Price
<input type="text"/>	<input type="text"/>	<input type="text"/>	<input type="text"/>	<input type="text"/>
Customer Mills Annual Sales	<input type="text"/>	<input type="text"/>	<input type="text"/>	<input type="text"/>
<input type="text"/>	<input type="text"/>	<input type="text"/>	<input type="text"/>	<input type="text"/>

Note

A relief according to the customer's wishes can affect the stability of the DUO-LOCK® extension.

Comments / Description of Application